

Strength of Materials (18CV 32)

Module 1 : Simple Stresses and Strains

Dr. H. Ananthan, Professor, VVIET, MYSURU

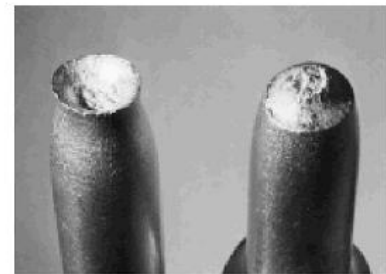
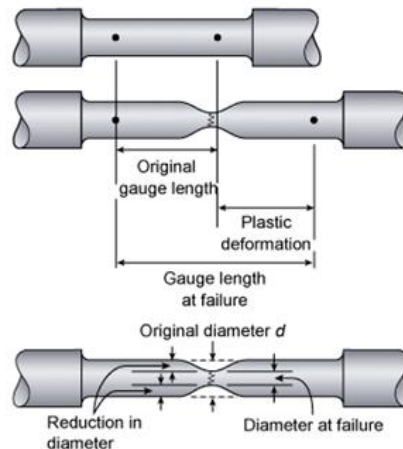
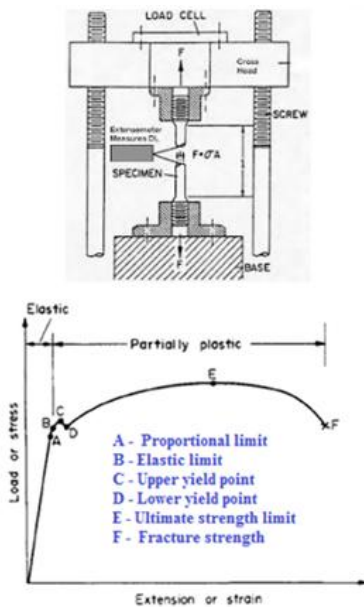

Cup and Cone fracture

Introduction, Definition and concept and of stress and strain. Hooke's law, Stress-Strain diagrams for ferrous and non-ferrous materials, factor of safety, Elongation of tapering bars of circular and rectangular cross sections, Elongation due to self-weight. Saint Venant's principle, Compound bars, Temperature stresses, Compound section subjected to temperature stresses, state of simple shear, Elastic constants and their relationship.

1.1 Introduction

In civil engineering structures, we frequently encounter structural elements such as *tie members, cables, beams, columns and struts* subjected to external actions called *forces or loads*. These elements have to be designed such that they have adequate *strength, stiffness and stability*.

The *strength* of a structural component is its ability to withstand applied forces without failure and this depends upon the *sectional dimensions and material characteristics*. For instance a steel rod can resist an applied tensile force more than an aluminium rod with similar diameter. Larger the sectional dimensions or stronger is the material greater will be the force carrying capacity.

Stiffness influences the deformation as a consequence of *stretching, shortening, bending, sliding, buckling, twisting and warping* due to applied forces as shown in the following figure. In a *deformable* body, the distance between two points changes due to the action of some kind of forces acting on it.

A weight suspended by two cables causes stretching of the cables. Cables are in *axial tension*.

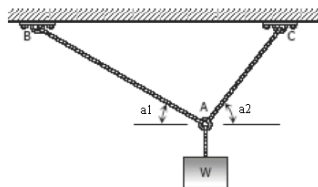

Inclined members undergo shortening, and stretching will be induced in the horizontal member. Inclined members are in *axial compression* and horizontal member is in *axial tension*.

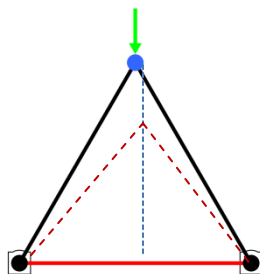

Bolt connecting the plates is subjected to sliding along the failure plane. *Shearing forces are induced*.

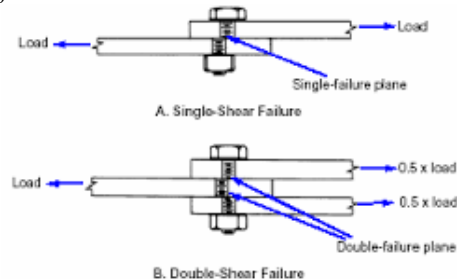

Cantilever beam subjected to *bending* due to transverse loads results in shortening in the bottom half and stretching in the top half of the beam.

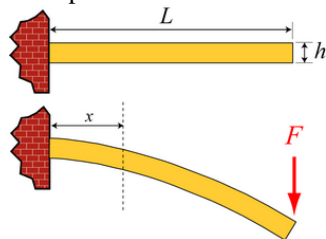

Cantilever beam subjected to twisting and warping due to *torsional moments*.

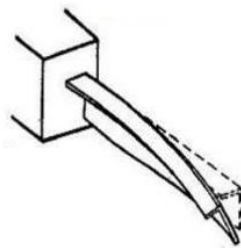

Buckling of long compression members due to *axial load*.

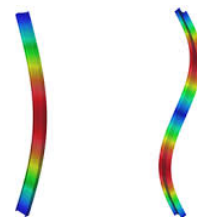

Such deformations also depend upon *sectional dimensions, length and material characteristics*. For instance a steel rod undergoes less of stretching than an aluminium rod with similar diameter and subjected to same tensile force.

Stability refers to the ability to maintain its original configuration. This again depends upon *sectional dimensions, length and material characteristics*. A steel rod with a larger length will buckle under a compressive action, while the one with smaller length can remain stable even though the sectional dimensions and material characteristics of both the rods are same.

The subject generally called *Strength of Materials* includes the study of the distribution of internal forces, the stability and deformation of various elements. It is founded both on the results of experiments and the application of the principles of mechanics and mathematics. The results obtained in the subject of strength of materials form an important part of the basis of scientific and engineering designs of different structural elements. Hence this is treated as subject of fundamental importance in design engineering. The study of this subject in the context of civil engineering refers to various methods of analyzing deformation behaviour of structural elements such as plates, rods, beams, columns, shafts etc.,.

1.2 Concepts and definitions

A load applied to a structural member will induce internal forces within the member called *stress resultants* and if computed based on unit cross sectional area then they are termed as *intensity of stress or simply stress* in the member.

The stresses induced in the structural member will cause different types of deformation in the member. If such deformations are computed based on unit dimensions then they are termed as *strain* in the member.

The stresses and strains that develop within a structural member must be calculated in order to assess its strength, deformations and stability. This requires a complete description of the geometry, constraints, applied loads and the material properties of the member.

The calculated stresses may then be compared to some measure of the strength of the material established through experiments. The calculated deformations in the member may be compared with respect limiting criteria established based on experience. The calculated buckling load of

the member may be compared with the applied load and the safety of the member can be assessed.

It is generally accepted that analytical methods coupled with experimental observations can provide solutions to problems in engineering with a fair degree of accuracy. Design solutions are worked out by a proper analysis of deformation of bodies subjected to surface and body forces along with material properties established through experimental investigations.

1.3 Simple Stress

Consider the suspended bar of original length L_0 and uniform cross sectional area A_0 with a force or load P applied to its end as shown in the following figure (a). Let us imagine that the bar is cut in to two parts by a section $x-x$ and study the equilibrium of the lower portion of the bar as shown in figure (b). At the lower end, we have the applied force P

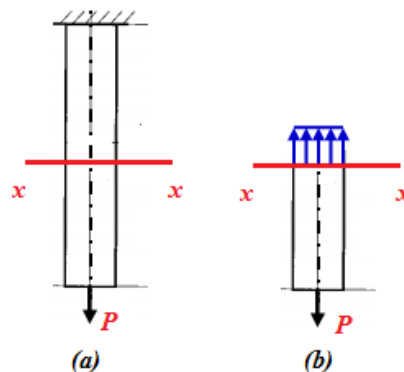

It can be noted that, the external force applied to a body in equilibrium is reacted by internal forces set up within the material. If a bar is subjected to an axial tension or compression, P , then the internal forces set up are distributed uniformly and the bar is said to be subjected to a *uniform direct or normal or simple stress*. The stress being defined as

$$\text{stress } (\sigma) = \frac{\text{Load } (P)}{\text{Sectional Area } (A)}$$

Note

- i. This is expressed as N/mm^2 or MPa.
- ii. Stress may thus be compressive or tensile depending on the nature of the load.
- iii. In some cases the stress may vary across any given section, and in such cases the stress at any point is given by the limiting value of $\delta P/\delta A$ as δA tends to zero.

1.4 Simple Strain

If a bar is subjected to a direct load, and hence a stress, the bar will change in length. If the bar has an original length L and changes in length by an amount δL as shown below,

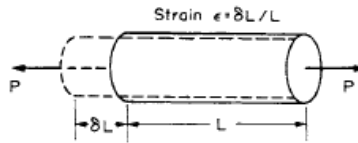

then the strain produced is defined as follows:

$$\text{strain } \epsilon = \frac{\text{change in length } (\delta L)}{\text{original length } (L)}$$

This strain is also termed as *longitudinal strain* as it is measured in the direction of application of load.

Note:

- i. Strain is thus a measure of the deformation of the member. It is simply a ratio of two quantities with the same units. It is non-dimensional, i.e. it has no units.
- ii. The deformations under load are very small. Hence the strains are also expressed as $\text{strain} \times 10^{-6}$. In such cases they are termed as *microstrain* ($\mu\epsilon$).
- iii. Strain is also expressed as a percentage strain : $\epsilon (\%) = (\delta L / L) 100$.

1.5 Elastic limit – Hooke's law

A structural member is said to be within elastic limit, if it returns to its original dimensions when load is removed. Within this load range, the deformations are proportional to the loads producing them. Hooke's law states that, “*the force needed to extend or compress a spring by some distance is proportional to that distance*”. This is indicated in the following figure.

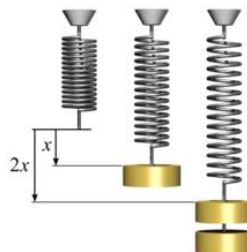

Since loads are proportional to the stresses they produce and deformations are proportional to the strains, the Hooke's law also implies that, “*stress is proportional to strain within elastic limit*”.

$$\text{stress } (\sigma) \propto \text{strain}(\varepsilon) \text{ or } \sigma/\varepsilon = \text{constant}$$

This law is valid within certain limits for most ferrous metals and alloys. It can even be assumed to apply to other engineering materials such as concrete, timber and non-ferrous alloys with reasonable accuracy.

The law is named after 17th-century British physicist Robert Hooke. He first stated the law in 1676 as a Latin anagram. He published the solution of his anagram in 1678 as: "utensio, sic vis" ("as the extension, so the force" or "the extension is proportional to the force").

1.6 Modulus of elasticity or Young's modulus

Within the elastic limits of materials, i.e. within the limits in which Hooke's law applies, it has been found that stress/strain = constant. This is termed the *modulus of elasticity or Young's modulus*. This is usually denoted by letter E and has the same units of stress. With $\sigma = P/A$ and $\varepsilon = \delta L/L$, the following expression for E can be derived.

$$E = \frac{\sigma}{\varepsilon} = \frac{P L}{A \delta L}$$

Young's modulus E is generally assumed to be the same in tension or compression and for most engineering materials has a high numerical value. Typically, E = 200000 MPa for steel. This is determined by conducting tension or compression test on specimens in the laboratory.

1.7 Tension test

In order to compare the strengths of various materials it is necessary to carry out some standard form of test to establish their relative properties. One such test is the standard tensile test. In this test a circular bar of uniform cross-section is subjected to a gradually increasing tensile load until failure occurs. Measurements of the change in length of a selected gauge length of the bar are recorded throughout the loading operation by means of extensometers. A graph of load against extension or stress against strain is produced.

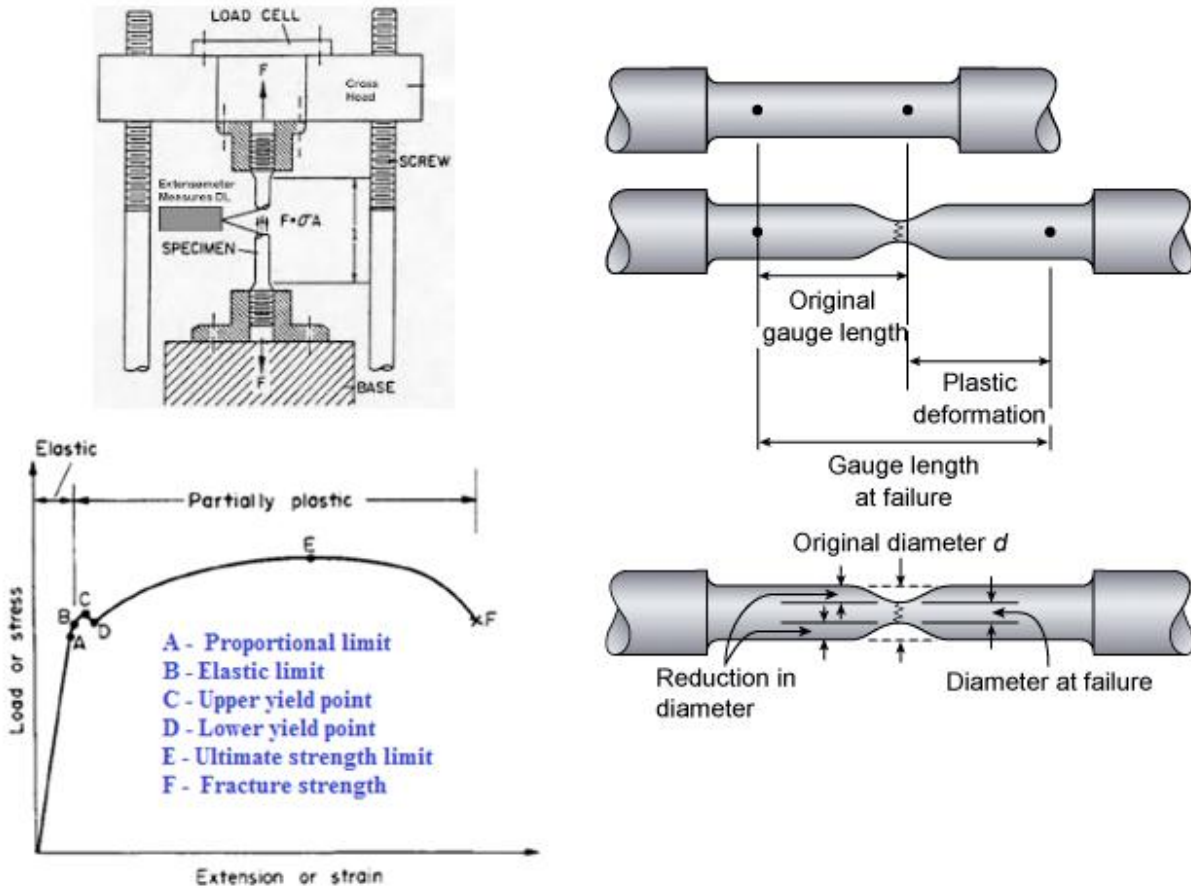

1.8 Stress – Strain diagrams for ferrous metals

The typical graph for a test on a mild (low carbon) steel bar is shown in the figure below. Other materials will exhibit different graphs but of a similar general form. Following salient points are to be noted:

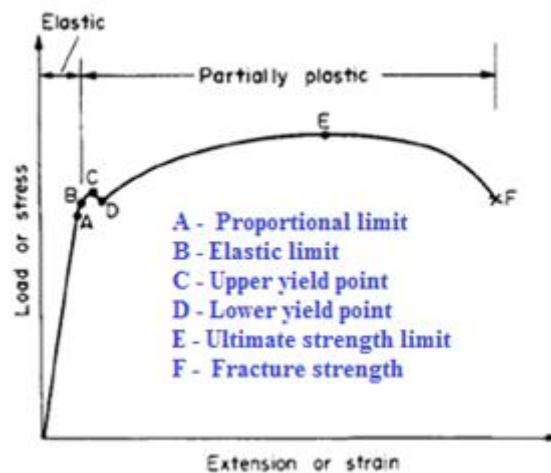

- i. In the initial stages of loading it can be observed that Hooke's law is obeyed, i.e. the material behaves elastically and stress is proportional to strain. This is indicated by the straight-line portion in the graph up to point A. Beyond this, some nonlinear nature of the graph can be seen. Hence this point (A) is termed the *limit of proportionality*. This region is also called *linear elastic range* of the material.
- ii. For a small increment in loading beyond A, the material may still be elastic. Deformations are completely recovered when load is removed but Hooke's law does not apply. The limiting point B for this condition is termed the *elastic limit*. This region refers to *nonlinear elastic range*. It is often assumed that points A and B are coincident.
- iii. Beyond the elastic limit (A or B), *plastic deformation* occurs and strains are not totally recoverable. Some *permanent deformation* or *permanent set* will be there when the specimen is unloaded. Point C, is termed as the *upper yield point*, and D, as the *lower yield point*. It is often assumed that points C and D are coincident. Strength corresponding to *this* point is termed as the *yield strength* of the material. Typically this strength corresponds to the load carrying capacity.
- iv. Beyond point (C or D), strain increases rapidly without proportionate increases in load or stress. The graph covers a much greater portion along the strain axis than in the elastic range of the material. The capacity of a material to allow these large plastic deformations is a measure of *ductility* of the material.
- v. Some increase in load is required to take the strain to point E on the graph. Between D and E the material is said to be in the *elastic-plastic state*. Some of the section remaining elastic and hence contributing to recovery of the original dimensions if load is removed, the remainder being plastic.
- vi. Beyond E, the cross-sectional area of the bar begins to reduce rapidly over a relatively small length. This result in the formation of *necking* accompanied with reduction in load and *fracture (cup and cone)* of the bar eventually occurs at point F.

- vii. The nominal stress at failure, termed the *maximum or ultimate tensile stress*, is given by the load at E divided by the original cross-sectional area of the bar. This is also known as the *ultimate tensile strength* of the material.
- viii. Owing to the large reduction in area produced by the necking process the actual stress at fracture is often greater than the ultimate tensile strength. Since, however, designers are interested in maximum loads which can be carried by the complete cross-section, the stress at fracture is not of any practical importance.

1.9 Influence of Repeated loading and unloading on yield strength

If load is removed from the test specimen after the yield point C has been passed, e.g. to some position S, as shown in the adjoining figure the unloading line ST can, for most practical purposes, be taken to be linear. A second load cycle, commencing with the permanent elongation associated with the strain OT, would then follow the line TS and continue along the previous curve to failure at F. It can be observed, that the repeated load cycle has the effect of increasing the elastic range of the material, i.e. raising the effective yield point from C to S. However, it is important to note that the tensile strength is unaltered. The procedure could be repeated along the line PQ, etc., and the material is said to have been work hardened. Repeated loading and unloading will produce a yield point approaching the ultimate stress value but the elongation or strain to failure will be very much reduced.

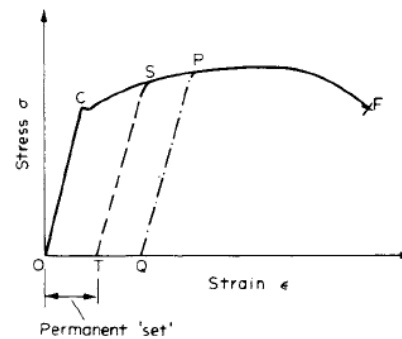

1.10 Non Ferrous metals

Typical stress-strain curves resulting from tensile tests on other engineering materials are shown in the following figure.

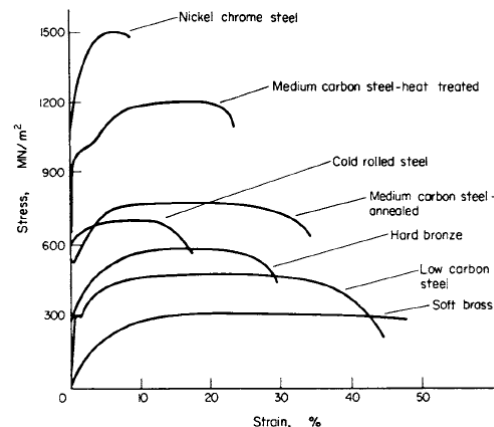

For certain materials, for example, high carbon steels and non-ferrous metals, it is not possible to detect any difference between the upper and lower yield points and in some cases yield point may not exist at all. In such cases a proof stress is used to indicate the onset of plastic strain. The 0.1% proof stress, for example, is that stress which, when removed, produces a permanent strain of 0.1% of the original gauge length as shown in the following figure.

The 0.1% proof stress can be determined from the tensile test curve as listed below.

- i. Mark the point P on the strain axis which is equivalent to 0.1% strain.
- ii. From P draw a line parallel with the initial straight line portion of the tensile test curve to cut the curve in N.
- iii. The stress corresponding to N is then the 0.1% proof stress.
- iv. A material is considered to satisfy its specification if the permanent set is no more than 0.1% after the proof stress has been applied for 15 seconds and removed.

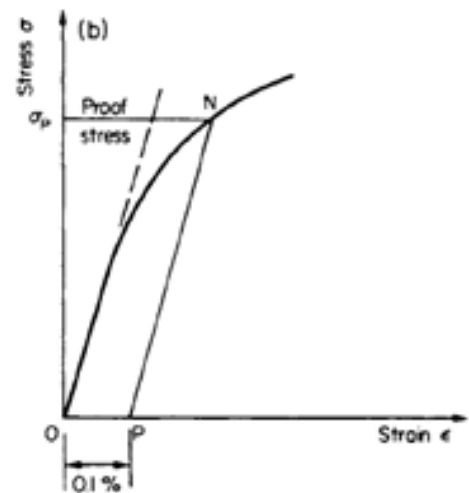

1.11 Allowable working stress-factor of safety

The most suitable strength criterion for any structural element under service conditions is that some maximum stress must not be exceeded such that plastic deformations do not occur. This value is generally known as the *maximum allowable working stress*. Because of uncertainties of loading conditions, design procedures, production methods etc., it is a common practice to introduce a *factor of safety* into structural designs. This is defined as follows:

$$\text{Factor of safety} = \frac{\text{Yield stress (or proof stress)}}{\text{Allowable working stress}}$$

1.12 Ductile materials

The capacity of a material to allow large extensions, i.e. the ability to be drawn out plastically, is termed its *ductility*. A quantitative value of the ductility is obtained by measurements of the percentage elongation or percentage reduction in area as defined below.

$$\% \text{ elongation} = \frac{\text{increase in gauge length to fracture}}{\text{original gauge length}} \times 100$$

$$\% \text{ reduction in area} = \frac{\text{cross sectional area of necked portion}}{\text{original area}} \times 100$$

Note:

A property closely related to ductility is malleability, which defines a material's ability to be hammered out into thin sheets. Malleability thus represents the ability of a material to allow permanent extensions in all lateral directions under compressive loadings.

1.13 Brittle materials

A brittle material is one which exhibits relatively small extensions to fracture so that the partially plastic region of the tensile test graph is much reduced. There is little or no necking at fracture for brittle materials. Typical tensile test curve for a brittle material could well look like the one shown in the adjoining figure.

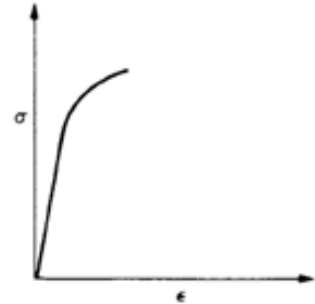

1.14 Lateral strain and Poisson's ratio

Till now we have focused on the longitudinal strain induced in the direction of application of the load. It has been observed that deformations also take place in the lateral direction. Consider the rectangular bar shown in the figure below and subjected to a tensile load.

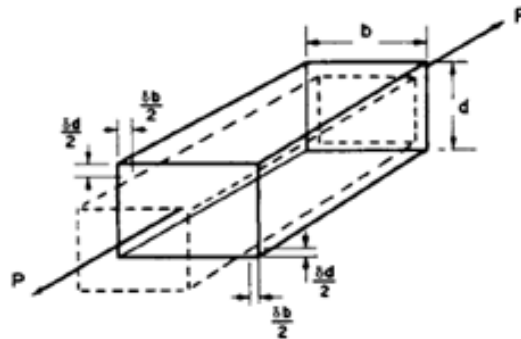

Under the action of this load the bar will increase in length by an amount δL giving a longitudinal strain in the bar: $\epsilon_L = \delta L/L$. The bar will also exhibit, however, a reduction in dimensions laterally, i.e. its breadth and depth will both reduce. The associated lateral strains will both be equal, and are of opposite sense to the longitudinal strain. These are computed as : $\epsilon_{lat} = \delta b/b = \delta d/d$.

It has been observed that within the elastic range the ratio of the lateral and longitudinal strains will always be constant. This ratio is termed *Poisson's ratio* (ν).

$$\nu = \frac{\epsilon_{lat}}{\epsilon_L}$$

The above equation can also be written as:

$$\epsilon_{lat} = \nu \epsilon_L = \nu \frac{\sigma}{E}$$

For most of the engineering materials the value of ν is found to be between 0.25 and 0.33.

Example 1

A bar of a rectangular section of 20 mm × 30 mm and a length of 500 mm is subjected to an axial compressive load of 60 kN. If $E = 102 \text{ kN/mm}^2$ and $\nu = 0.34$, determine the changes in the length and the sides of the bar.

- Since the bar is subjected to compression, there will be decrease in length, increase in breadth and depth. These are computed as shown below
- $L = 500 \text{ mm}$, $b = 20 \text{ mm}$, $d = 30 \text{ mm}$, $P = 60 \times 1000 = 60000 \text{ N}$, $E = 102000 \text{ N/mm}^2$
- Cross-sectional area $A = 20 \times 30 = 600 \text{ mm}^2$
- Compressive stress $\sigma = P/A = 60000/600 = 100 \text{ N/mm}^2$
- Longitudinal strain $\epsilon_L = \sigma/E = 100/102000 = 0.00098$
- Lateral strain $\epsilon_{lat} = \nu \epsilon_L = 0.34 \times 0.00098 = 0.00033$
- Decrease in length $\delta L = \epsilon_L L = 0.00098 \times 500 = 0.49 \text{ mm}$
- Increase in breadth $\delta b = \epsilon_{lat} b = 0.00033 \times 20 = 0.0066 \text{ mm}$
- Increase in depth $\delta d = \epsilon_{lat} d = 0.00033 \times 30 = 0.0099 \text{ mm}$

Example 2

Determine the stress in each section of the bar shown in the following figure when subjected to an axial tensile load of 20 kN. The central section is of square cross-section; the other portions are of circular section. What will be the total extension of the bar? For the bar material $E = 210000 \text{ MPa}$.

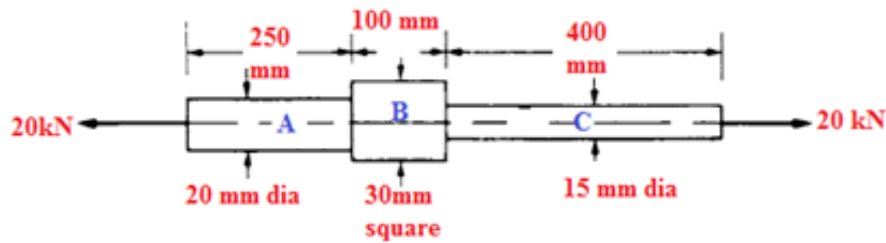

The bar consists of three sections with change in diameter. Loads are applied only at the ends. The stress and deformation in each section of the bar are computed separately. The total extension of the bar is then obtained as the sum of extensions of all the three sections. These are illustrated in the following steps.

The bar is in equilibrium under the action of applied forces

Stress in each section of bar = P/A and $P = 20000N$

- i. Area of Bar A = $\pi \times 20^2/4 = 314.16 \text{ mm}^2$
- ii. Stress in Bar A : $\sigma_A = 20000/ 314.16 = 63.66\text{MPa}$
- iii. Area of Bar B = $30 \times 30 = 900 \text{ mm}^2$
- iv. Stress in Bar B : $\sigma_B = 20000/ 900 = 22.22\text{MPa}$
- v. Area of Bar C = $\pi \times 15^2/4 = 176.715 \text{ mm}^2$
- vi. Stress in Bar C : $\sigma_C = 20000/ 176.715 = 113.18\text{MPa}$

Extension of each section of bar = $\sigma L/E$ and $E = 210000 \text{ MPa}$

- i. Extension of Bar A = $63.66 \times 250 / 210000 = 0.0758 \text{ mm}$
- ii. Extension of Bar B = $22.22 \times 100 / 210000 = 0.0106 \text{ mm}$
- iii. Extension of Bar C = $113.18 \times 400 / 210000 = 0.2155 \text{ mm}$

Total extension of the bar = **0.302mm**

Example 3

Determine the overall change in length of the bar shown in the figure below with following data:

$E = 100000 \text{ N/mm}^2$

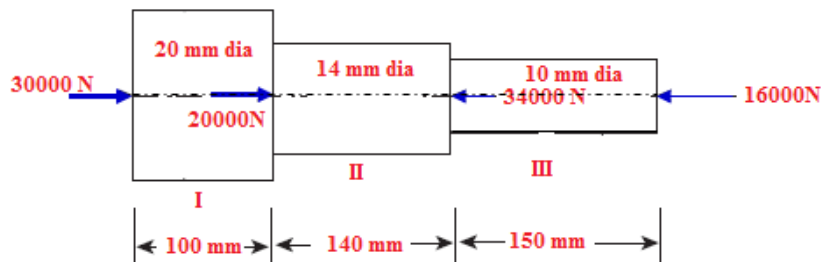

The bar is with varying cross-sections and subjected to forces at ends as well as at other interior locations. It is necessary to study the equilibrium of each portion separately and compute the change in length in each portion. The total change in length of the bar is then obtained as the sum of extensions of all the three sections as shown below.

Forces acting on each portion of the bar for equilibrium

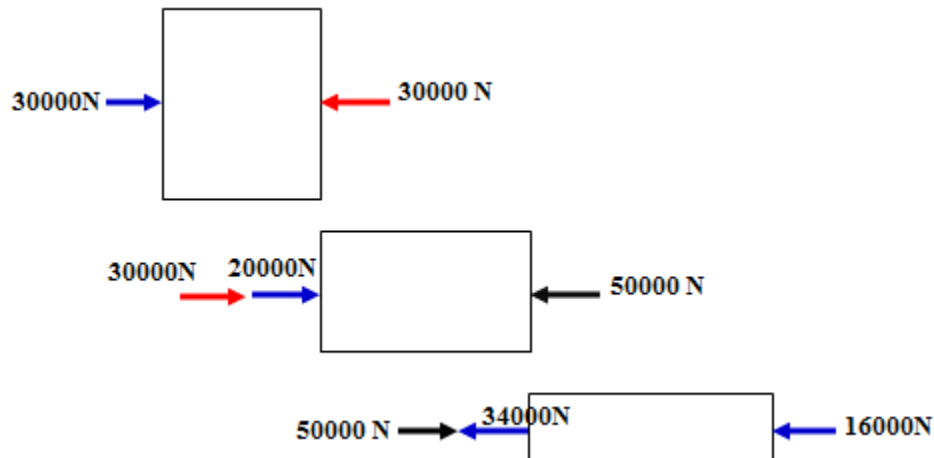

Sectional Areas

$$A_I = \frac{\pi \times 20^2}{4} = 314.16 \text{ mm}^2; A_{II} = \frac{\pi \times 14^2}{4} = 153.94 \text{ mm}^2; A_{III} = \frac{\pi \times 10^2}{4} = 78.54 \text{ mm}^2$$

Change in length in Portion I

Portion I of the bar is subjected to an axial compression of 30000N. This results in *decrease* in length which can be computed as

$$\delta L_I = \frac{P_I L_I}{A_I E} = \frac{30000 \times 100}{314.16 \times 100000} = 0.096 \text{ mm}$$

Change in length in Portion II

Portion II of the bar is subjected to an axial compression of 50000N (30000 + 20000). This results in *decrease* in length which can be computed as

$$\delta L_{II} = \frac{P_{II} L_{II}}{A_{II} E} = \frac{50000 \times 140}{153.94 \times 100000} = 0.455 \text{ mm}$$

Change in length in Portion III

Portion III of the bar is subjected to an axial compression of (50000 – 34000) = 16000N. This results in *decrease* in length which can be computed as

$$\delta L_{III} = \frac{P_{III} L_{III}}{A_{III} E} = \frac{16000 \times 150}{78.54 \times 100000} = 0.306 \text{ mm}$$

Since each portion of the bar results in decrease in length, they can be added without any algebraic signs.

Hence Total decrease in length = $0.096 + 0.455 + 0.306 = \underline{\underline{0.857\text{mm}}}$

Note:

For equilibrium, if some portion of the bar may be subjected to tension and some other portion to compression resulting in increase or decrease in length in different portions of the bar. In such cases, the total change in length is computed as the sum of change in length of each portion of the bar with proper algebraic signs. Generally positive sign (+) is used for increase in length and negative sign (-) for decrease in length.

1.15 Elongation of tapering bars of circular cross section

Consider a circular bar uniformly tapered from diameter d_1 at one end and gradually increasing to diameter d_2 at the other end over an axial length L as shown in the figure below.

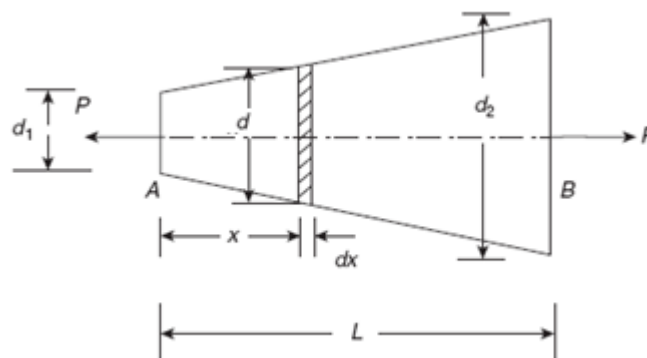

Since the diameter of the bar is continuously changing, the elongation is first computed over an elementary length and then integrated over the entire length. Consider an elementary strip of diameter d and length dx at a distance of x from end A.

Using the principle of similar triangles the following equation for d can be obtained

$$d = d_1 + \frac{d_2 - d_1}{L}x = d_1 + kx, \text{ where } k = \frac{d_2 - d_1}{L}$$

$$\text{Cross-sectional area of the bar at } x : A_x = \frac{\pi (d_1 + kx)^2}{4}$$

$$\text{Axial stress at } x : \sigma_x = \frac{P}{A_x} = \frac{4P}{\pi (d_1 + kx)^2}$$

$$\text{Change in length over } dx : \delta dx = \frac{\sigma_x dx}{E} = \frac{4P dx}{\pi E (d_1 + kx)^2}$$

$$\text{Total change in length: } \delta L = \int_0^L \frac{4P dx}{\pi E (d_1 + kx)^2} = \frac{4P}{\pi E} \left[\frac{(d_1 + kx)^{-1}}{-k} \right]_0^L$$

$$\text{After rearranging the terms: } \delta L = -\frac{4P}{\pi E k} \left[\frac{1}{(d_1 + kx)} \right]_0^L$$

$$\text{Upon substituting the limits: } \delta L = -\frac{4P}{\pi E k} \left[\frac{1}{(d_1 + kL)} - \frac{1}{d_1} \right]$$

$$\text{After rearranging the terms: } \delta L = \frac{4P}{\pi E k} \left[\frac{1}{d_1} - \frac{1}{(d_1 + kL)} \right]$$

$$\text{But } (d_1 + kL) = d_1 + \frac{d_2 - d_1}{L} L = d_2$$

$$\text{With the above substitution: } \delta L = \frac{4P}{\pi E k} \left[\frac{1}{d_1} - \frac{1}{d_2} \right] = \frac{4P}{\pi E k} \left[\frac{d_2 - d_1}{d_1 d_2} \right]$$

Substituting for $k = \frac{d_2 - d_1}{L}$ in the above expression, following equation for elongation of tapering bar of circular section can be obtained

$$\text{Total change in length: } \delta L = \frac{4P L}{\pi E d_1 d_2}$$

Example 4

A bar uniformly tapers from diameter 20 mm at one end to diameter 10 mm at the other end over an axial length 300 mm. This is subjected to an axial compressive load of 7.5 kN. If $E = 100 \text{ kN/mm}^2$, determine the maximum and minimum axial stresses in bar and the total change in length of the bar.

$$P = 7500 \text{ N}, E = 100000 \text{ N/mm}^2, d_1 = 10\text{mm}, d_2 = 20\text{mm}, L = 300\text{mm}$$

- Minimum compressive stress occurs at $d_2 = 20\text{mm}$ as the sectional area is maximum.
- Area at $d_2 = \frac{\pi \times 20^2}{4} = 314.16 \text{ mm}^2$
- $\sigma_{min} = \frac{7500}{314.16} = 23.87 \text{ MPa}$
- Maximum compressive stress occurs at $d_1 = 10\text{mm}$ as the sectional area is minimum.
- Area at $d_1 = \frac{\pi \times 10^2}{4} = 78.54 \text{ mm}^2$
- $\sigma_{min} = \frac{7500}{78.54} = 95.5 \text{ MPa}$
- Total decrease in length: $\delta L = \frac{4P L}{\pi E d_1 d_2} = \frac{4 \times 7500 \times 300}{\pi \times 100000 \times 10 \times 20} = 0.143 \text{ mm}$

1.16 Elongation of tapering bars of rectangular cross section

Consider a bar of same thickness t throughout its length, tapering uniformly from a breadth B at one end to a breadth b at the other end over an axial length L . The bar is subjected to an axial force P as shown in the figure below.

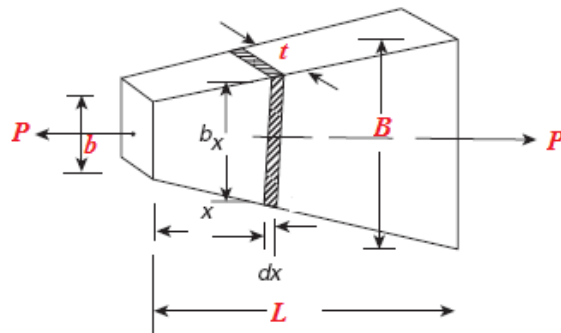

Since the breadth of the bar is continuously changing, the elongation is first computed over an elementary length and then integrated over the entire length. Consider an elementary strip of breadth b_x and length dx at a distance of x from left end.

Using the principle of similar triangles the following equation for b_x can be obtained

$$b_x = b + \frac{B-b}{L}x = b + kx, \text{ where } k = \frac{B-b}{L}$$

Cross-sectional area of the bar at x : $A_x = b_x t = (b + kx)t$

$$\text{Axial stress at } x: \sigma_x = \frac{P}{A_x} = \frac{P}{(b+kx)t}$$

$$\text{Change in length over } dx: \delta dx = \frac{\sigma_x dx}{E} = \frac{P dx}{Et(b+kx)}$$

$$\text{Total change in length: } \delta L = \int_0^L \frac{P dx}{Et(b+kx)} = \frac{P}{Et k} [\ln(b+kx)]_0^L$$

$$\text{Upon substituting the limits: } \delta L = \frac{P}{Et k} [\ln(b+kL) - \ln(b)]$$

$$\text{But } (b+kL) = b + \frac{B-b}{L} L = B$$

$$\text{With the above substitution: } \delta L = \frac{P}{Et k} [\ln(B) - \ln(b)] = \frac{P}{Et k} \ln(B/b)$$

Substituting for $k = \frac{B-b}{L}$ in the above expression, following equation for elongation of tapering bar of rectangular section can be obtained

$$\delta L = \frac{P L}{E t (B - b)} \ln (B / b)$$

Example 5

An aluminium flat of a thickness of 8 mm and an axial length of 500 mm has a width of 15 mm tapering to 25 mm over the total length. It is subjected to an axial compressive force P , so that the total change in the length of flat does not exceed 0.25 mm. What is the magnitude of P , if $E = 67,000 \text{ N/mm}^2$ for aluminium?

$t = 8 \text{ mm}$, $B = 25 \text{ mm}$, $b = 15 \text{ mm}$, $L = 500 \text{ mm}$, $\delta L = 0.25 \text{ mm}$, $E = 67000 \text{ MPa}$, $P = ?$

$$P = \frac{E t (B - b) \delta L}{\ln(B / b) L} = \frac{67000 \times 8 \times (25 - 15) \times 0.25}{\ln(25 / 15) \times 500} = 5.246 \text{ kN}$$

Note:

Instead of using the formula, this problem can be solved from first principles as indicated in section 1.16.

1.17 Elongation in Bar Due to Self-Weight

Consider a bar of a cross-sectional area of A and a length L is suspended vertically with its upper end rigidly fixed as shown in the adjoining figure. Let the weight density of the bar is ρ . Consider a section $y-y$ at a distance y from the lower end.

Weight of the portion of the bar below $y-y = \rho A y$

Stress at $y-y : \sigma_y = \rho A y / A = \rho y$

Strain at $y-y : \epsilon_y = \rho y / E$

Change in length over $dy : \delta dy = \rho y dy / E$

$$\text{Total change in length : } \delta L = \int_0^L \frac{\rho y dy}{E} = \left[\frac{\rho y^2}{2E} \right]_0^L = \frac{\rho L^2}{2E}$$

$$\text{This can also be written as : } \delta L = \frac{(\rho A L)L}{2AE} = \frac{WL}{2AE}$$

$W = \rho A L$ represents the total weight of the bar

Note:

The stress in the bar gradually increases linearly from zero at bottom to ρL at top as shown below.

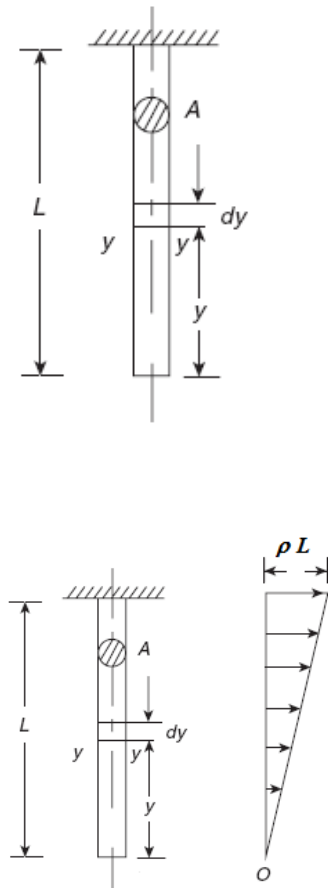

Example 6

A stepped steel bar is suspended vertically. The diameter in the upper half portion is 10 mm, while the diameter in the lower half portion is 6 mm. What are the stresses due to self-weight in sections B and A as shown in the figure. $E = 200 \text{ kN/mm}^2$. Weight density, $\rho = 0.7644 \times 10^{-3} \text{ N/mm}^3$. What is the change in its length if $E = 200000 \text{ MPa}$?

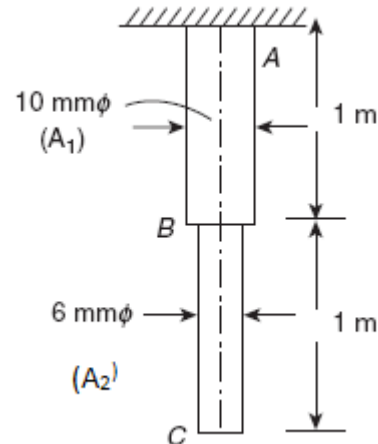

Stress at B will be due to weight of portion of the bar BC

$$\text{Sectional area of BC: } A_2 = \pi \times 6^2/4 = 28.27 \text{ mm}^2$$

$$\text{Weight of portion BC: } W_2 = \rho A_2 L_2 = 0.7644 \times 10^{-3} \times 28.27 \times 1000 = 21.61 \text{ N}$$

$$\text{Stress at B: } \sigma_B = W_2/A_2 = 21.61/28.27 = \mathbf{0.764 \text{ MPa}}$$

Stress at A will be due to weight of portion of the bar BC + AB

$$\text{Sectional area of AB: } A_1 = \pi \times 10^2/4 = 78.54 \text{ mm}^2$$

$$\text{Weight of portion AB: } W_1 = \rho A_1 L_1 = 0.7644 \times 10^{-3} \times 78.54 \times 1000 = 60.04 \text{ N}$$

$$\text{Stress at A: } \sigma_c = (W_1+W_2)/A_1 = (60.04+ 21.61) / 78.54 = \mathbf{1.04 \text{ MPa}}$$

Change in Length in portion BC

This is caused due to weight of BC and is computed as:

$$\delta L_{BC} = \frac{W_2 L_2}{2 A_2 E} = \frac{21.61 \times 1000}{2 \times 28.27 \times 200000} = 0.00191 \text{ mm}$$

Change in Length in portion AB

This is caused due to weight of AB and due to weight of BC acting as a concentrated load at B and is computed as:

$$\delta L_{AB} = \frac{W_1 L_1}{2 A_1 E} + \frac{W_2 L_1}{E A_1} = \frac{60.04 \times 1000}{2 \times 78.54 \times 200000} + \frac{21.61 \times 1000}{200000 \times 78.54} = 0.0033 \text{ mm}$$

$$\text{Total change in length} = 0.00191 + 0.0033 = \mathbf{0.00521 \text{ mm}}$$

1.18 Saint Venant's principle

In 1855, the French Elasticity theorist *Adhemar Jean Claude Barre de Saint-Venant* stated that the difference between the effects of two different but statically equivalent loads becomes very small at sufficiently large distances from the load. The stresses and strains in a body at points

that are sufficiently remote from points of application of load depend only on the static resultant of the loads and not on the distribution of loads.

Stress concentration is the increase in stress along the cross-section that maybe caused by a point load or by any another discontinuity such as a hole which brings about an abrupt change in the cross sectional area.

In St.Venant's Principle experiment, we fix two strain gages, one near the central portion of the specimen and one near the grips of the Universal Testing Machine's (UTM) upper (stationary) holding chuck.. The respective strain values obtained from both the gages are measured and then plotted with respect to time. Since stress is proportional to strain, as per St.Venant's principle, the stress will be concentrated near the point of application of load. Although the average stress along the uniform cross section remains constant, at the point of application of load, the stress is distributed as shown in figure below with stress being concentrated at the load point. The further the distance from the point of application of load, the more uniform the stress is distributed across the cross section.

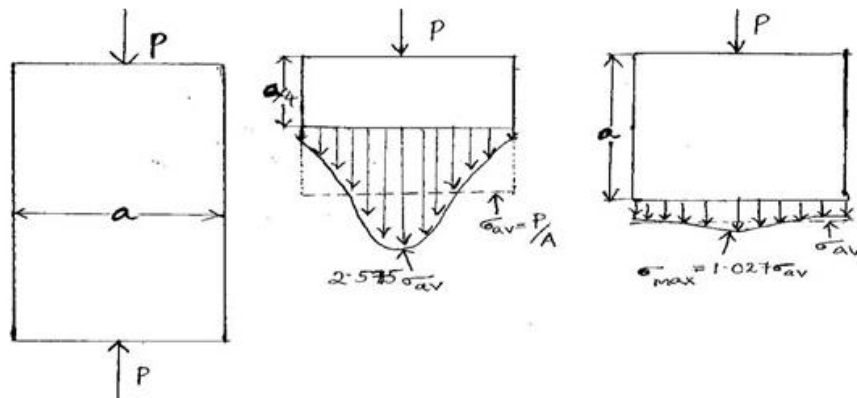

1.19 Compound or composite bars

A composite bar can be made of two bars of different materials rigidly fixed together so that both bars strain together under external load. As the strains in the two bars are same, the stresses in the two bars will be different and depend on their respective modulus of elasticity. A stiffer bar will share major part of external load.

In a composite system the two bars of different materials may act as suspenders to a third rigid bar subjected to loading. As the change in length of both bars is the same, different stresses are produced in two bars.

1.19.1 Stresses in a Composite Bar

Let us consider a composite bar consisting of a solid bar, of diameter d completely encased in a hollow tube of outer diameter D and inner diameter d , subjected to a tensile force P as shown in the following figure.

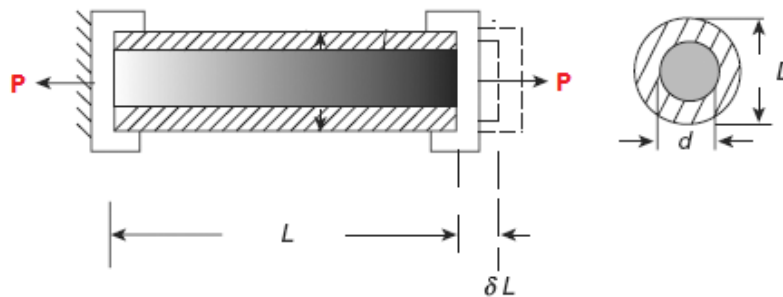

Let the extension of composite bar of length L be δL . Let E_S and E_H be the modulus of elasticity of solid bar and hollow tube respectively. Let σ_S and σ_H be the stresses developed in the solid bar and hollow tube respectively.

Since change in length of solid bar is equal to the change in length of hollow tube, we can establish the relation between the stresses in solid bar and hollow tube as shown below :

$$\frac{\sigma_S L}{E_S} = \frac{\sigma_H L}{E_H} \text{ or } \sigma_S = \sigma_H \frac{E_S}{E_H}$$

$$\text{Area of cross section of the hollow tube : } A_H = \frac{\pi(D^2 - d^2)}{4}$$

$$\text{Area of cross section of the solid bar : } A_S = \frac{\pi d^2}{4}$$

$$\text{Load carried by the hollow tube : } P_H = \sigma_H A_H \text{ and Load carried by the solid bar : } P_S = \sigma_S A_S$$

$$\text{But } P = P_S + P_H = \sigma_S A_S + \sigma_H A_H$$

With $\sigma_S = \sigma_H \frac{E_S}{E_H}$, the following equation can be written

$$P = \sigma_H \frac{E_S}{E_H} A_S + \sigma_H A_H = \sigma_H \left(A_H + \frac{E_S}{E_H} A_S \right)$$

E_S/E_H is called *modular ratio*. Using the above equation stress in the hollow tube can be calculated. Next, the stress in the solid bar can be calculated using the equation $P = \sigma_S A_S + \sigma_H A_H$.

Example 7

A flat bar of steel of 24 mm wide and 6 mm thick is placed between two aluminium alloy flats 24 mm × 9 mm each. The three flats are fastened together at their ends. An axial tensile load of 20 kN is applied to the composite bar. What are the stresses developed in steel and aluminium alloy? Assume $E_S = 210000$ MPa and $E_A = 70000$ MPa.

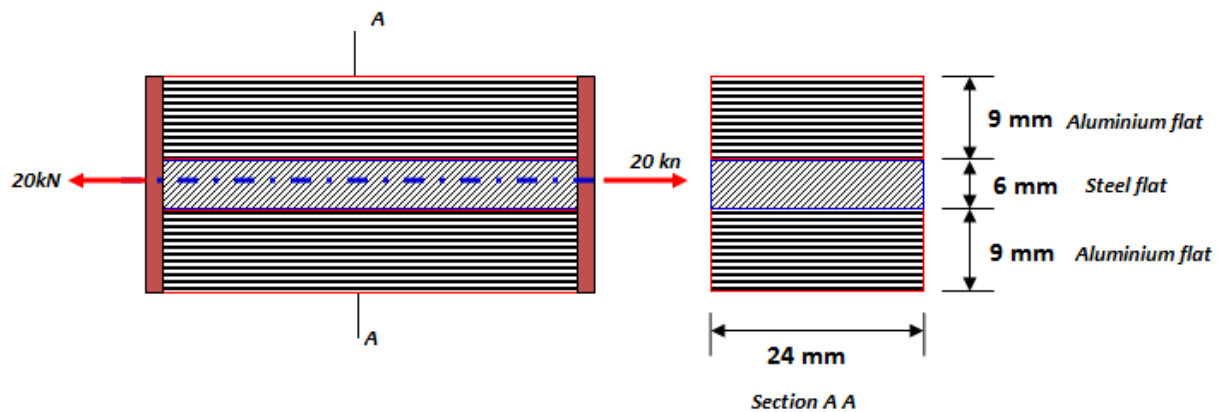

Area of Steel flat: $A_S = 24 \times 6 = 144 \text{ mm}^2$

Area of Aluminium alloy flats: $A_A = 2 \times 24 \times 9 = 432 \text{ mm}^2$

Since all the flats elongate by the same extent, we have the condition that $\frac{\sigma_S L}{E_S} = \frac{\sigma_A L}{E_A}$.

The relationship between the stresses in steel and aluminum flats can be established as:

$$\sigma_S = \sigma_A \frac{E_S}{E_A} = 3 \sigma_A$$

Since $P = P_S + P_A = \sigma_S A_S + \sigma_A A_A$. This can be written as

$$P = 3\sigma_A A_S + \sigma_A A_A = \sigma_A (3A_S + A_A)$$

From which stress in aluminium alloy flat can be computed as:

$$\sigma_A = \frac{P}{(3A_s + A_A)} = \frac{20 \times 1000}{(3 \times 144 + 432)} = 23.15 \text{ MPa}$$

Stress in steel flat can be computed as:

$$\sigma_s = 3 \times 23.15 = 69.45 \text{ MPa}$$

Example 8

A short post is made by welding steel plates into a square section and then filling inside with concrete. The side of square is 200 mm and the thickness $t = 10$ mm as shown in the figure. The steel has an allowable stress of 140 N/mm^2 and the concrete has an allowable stress of 12 N/mm^2 . Determine the allowable safe compressive load on the post. $E_C = 20 \text{ GPa}$, $E_S = 200 \text{ GPa}$.

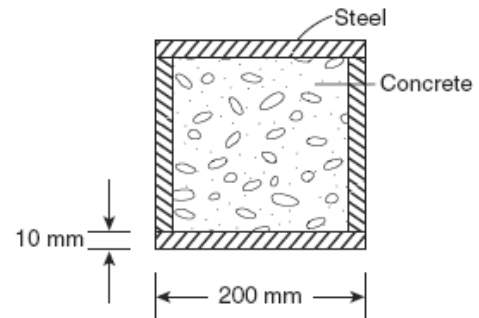

Since the composite post is subjected to compressive load, both concrete and steel tube will shorten by the same extent. Using this condition following relation between stresses in concrete and steel can be established.

$$\frac{\sigma_C L}{E_C} = \frac{\sigma_S L}{E_S} \text{ or } \sigma_S = \sigma_C \frac{E_S}{E_C} = 10 \sigma_C$$

Assume that load is such that $\sigma_s = 140 \text{ N/mm}^2$. Using the above relationship, the stress in concrete corresponding to this load can be calculated as follows:

$$140 = 10 \sigma_C \text{ or } \sigma_C = 14 \text{ N/mm}^2 > 12 \text{ N/mm}^2$$

Hence the assumed load is not a safe load.

Instead assume that load is such that $\sigma_c = 12 \text{ N/mm}^2$. The stress in steel corresponding to this load can be calculated as follows:

$$\sigma_s = 12 \times 10 \text{ or } \sigma_s = 120 \text{ N/mm}^2 < 140 \text{ N/mm}^2$$

Hence the assumed load is a safe load which is calculated as shown below.

Area of concrete section $A_c = 180 \times 180 = 32400 \text{ mm}^2$.

Area of steel tube $A_s = 200 \times 200 - 32400 = 7600 \text{ mm}^2$.

$$P = \sigma_c A_c + \sigma_s A_s = 12 \times 32400 + 120 \times 7600 = \mathbf{1300.8 \text{ kN}}$$

Example 9

A rigid bar is suspended from two wires, one of steel and other of copper, length of the wire is 1.2 m and diameter of each is 2.5 mm. A load of 500 N is suspended on the rigid bar such that the rigid bar remains horizontal. If the distance between the wires is 150 mm, determine the location of line of application of load. What are the stresses in each wire and by how much distance the rigid bar comes down? Given $E_s = 3E_{cu} = 201000 \text{ N/mm}^2$.

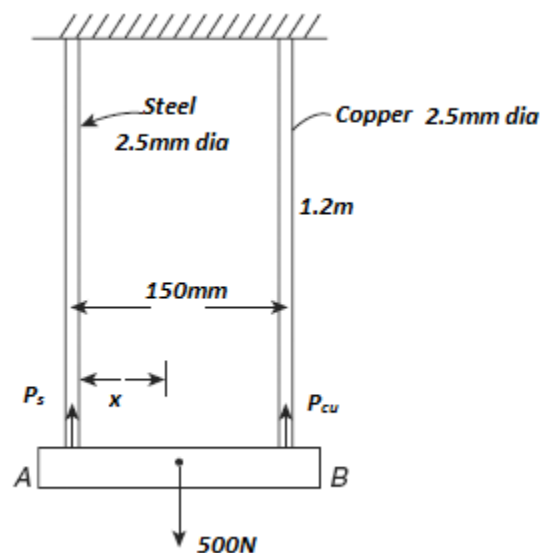

i. Area of copper wire (A_{cu}) = Area of steel wire (A_s) = $\pi \times 2.5^2 / 4 = 4.91 \text{ mm}^2$

ii. For the rigid bar to be horizontal, elongation of both the wires must be same. This condition leads to the following relationship between stresses in steel and copper wires as:

$$\sigma_s = \frac{E_s}{E_{cu}} \sigma_{cu} = 3 \sigma_{cu}$$

iii. Using force equilibrium, the stress in copper and steel wire can be calculated as:

$$P = P_s + P_{cu} = \sigma_s A_s + \sigma_{cu} A_{cu} = 3 \sigma_{cu} A_s + \sigma_{cu} A_{cu} = \sigma_{cu} (3A_s + A_{cu})$$

$$\sigma_{cu} = \frac{P}{(A_{cu} + 3A_s)} = \frac{500}{(4.91 + 3 \times 4.91)} = 25.46 \text{ MPa}$$

$$\sigma_s = 3 \times 25.46 = 76.37 \text{ MPa}$$

- iv. Downward movement of rigid bar = elongation of wires

$$\delta L_s = \frac{\sigma_s}{E_s} L = \frac{76.37}{201000} \times 1200 = 0.456 \text{ mm}$$

- v. Position of load on the rigid bar is computed by equating moments of forces carried by steel and copper wires about the point of application of load on the rigid bar.

$$P_s x = P_c (150 - x)$$

$$(76.37 \times 4.91)x = (25.46 \times 4.91) (150 - x)$$

$$\frac{x}{150 - x} = 0.333$$

$$x = 37.47 \text{ mm from steel wire}$$

Note:

If the load is suspended at the centre of rigid bar, then both steel and copper wire carry the same load. Hence the stress in the wires is also same. As the moduli of elasticity of wires are different, strains in the wires will be different. This results in unequal elongation of wires causing the rigid bar to rotate by some magnitude. This can be prevented by offsetting the load or with wires having different length or with different diameter such that elongation of wires will be same.

Example 10

A load of 2MN is applied on a column 500mm x 500mm. The column is reinforced with four steel bars of 12mm dia, one in each corner. Find the stresses in concrete and steel bar. $E_s = 2.1 \times 10^5 \text{ N/mm}^2$ and $E_c = 1.4 \times 10^4 \text{ N/mm}^2$.

- i. Area of steel bars: $A_s = 4 \times (\pi \times 12^2/4) = 452.4 \text{ mm}^2$
- ii. Area of concrete: $A_c = 500 \times 500 - 452.4 = 249547.6 \text{ mm}^2$

iii. Relation between stress in steel and concrete : $\sigma_s = \frac{E_s}{E_c} \sigma_c = \frac{2.1 \times 10^5}{1.4 \times 10^4} \sigma_c = 15 \sigma_c$

iv. $P = P_s + P_c = \sigma_s A_s + \sigma_c A_c = 15 \sigma_c A_s + \sigma_c A_c = \sigma_c (15A_s + A_c)$

v. *Stress in concrete* $\sigma_c = \frac{P}{(A_c + 15A_s)} = \frac{2 \times 10^6}{(249547.6 + 15 \times 452.4)} = 7.8 \text{ MPa}$

vi. *Stress in steel* $\sigma_s = 15 \sigma_c = 15 \times 7.8 = 117 \text{ MPa}$

1.20 Temperature stresses in a single bar

If a bar is held between two unyielding (rigid) supports and its temperature is raised, then a compressive stress is developed in the bar as its free thermal expansion is prevented by the rigid supports. Similarly, if its temperature is reduced, then a tensile stress is developed in the bar as its free thermal contraction is prevented by the rigid supports. Let us consider a bar of diameter d and length L rigidly held between two supports as shown in the following figure. Let α be the coefficient of linear expansion of the bar and its temperature is raised by ΔT ($^{\circ}\text{C}$)

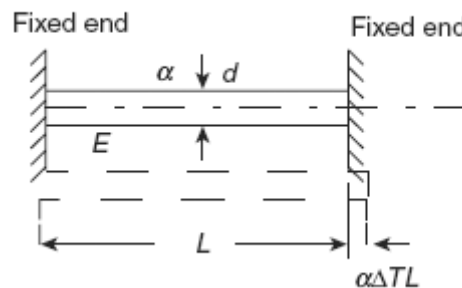

- Free thermal expansion in the bar = $\alpha \Delta T L$.
- Since the supports are rigid, the final length of the bar does not change. The fixed ends exert compressive force on the bar so as to cause shortening of the bar by $\alpha \Delta T L$.
- Hence the compressive strain in the bar = $\alpha \Delta T L / L = \alpha \Delta T$
- Compressive stress = $\alpha \Delta T E$
- Hence the thermal stresses introduced in the bar = $\alpha \Delta T E$

Note:

The bar can buckle due to large compressive forces generated in the bar due to temperature increase or may fracture due to large tensile forces generated due to temperature decrease.

Example 11

A rail line is laid at an ambient temperature of 30°C . The rails are 30 m long and there is a clearance of 5 mm between the rails. If the temperature of the rail rises to 60°C , what is the stress developed in the rails?. Assume $\alpha = 11.5 \times 10^{-6}/^{\circ}\text{C}$, $E = 2,10,000 \text{ N/mm}^2$

- $L = 30,000 \text{ mm}$, $\alpha = 11.5 \times 10^{-6}/^{\circ}\text{C}$, Temperature rise $\Delta T = 60 - 30 = 30^{\circ}\text{C}$
- Free expansion of rails $= \alpha \Delta T L = 11.5 \times 10^{-6} \times 30 \times 30000 = 10.35 \text{ mm}$
- Thermal expansion prevented by rails $= \text{Free expansion} - \text{clearance} = 10.35 - 5 = 5.35 \text{ mm}$
- Strain in the rails $\epsilon = 5.35/30000 = 0.000178$
- Compressive stress in the rails $= \epsilon \times E = 0.000178 \times 210000 = \underline{\underline{37.45 \text{ N/mm}^2}}$.

1.21 Temperature Stresses in a Composite Bar

A composite bar is made up of two bars of different materials perfectly joined together so that during temperature change both the bars expand or contract by the same amount. Since the coefficient of expansion of the two bars is different thermal stresses are developed in both the bars. Consider a composite bar of different materials with coefficients of expansion and modulus of elasticity, as α_1, E_1 and α_2, E_2 , respectively, as shown in the following figure. Let the temperature of the bar is raised by ΔT and $\alpha_1 > \alpha_2$

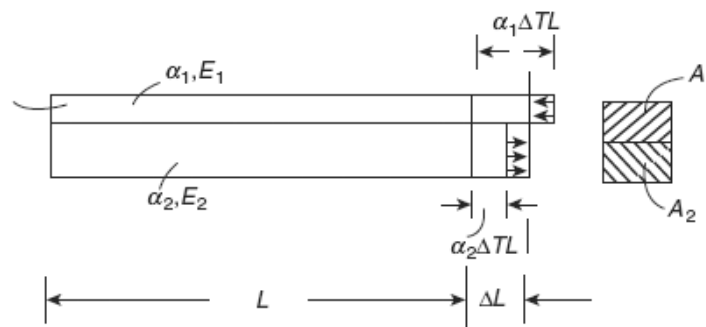

Free expansion in bar 1 = $\alpha_1 \Delta T L$ and Free expansion in bar 2 = $\alpha_2 \Delta T L$. Since both the bars expand by ΔL together we have the following conditions:

- Bar 1: $\Delta L < \alpha_1 \Delta T L$. The bar gets compressed resulting in compressive stress
- Bar 2: $\Delta L > \alpha_2 \Delta T L$. The bar gets stretched resulting in tensile stress.

$$\text{Compressive strain in Bar 1 : } \varepsilon_1 = \frac{\alpha_1 \Delta T L - \Delta L}{L}$$

$$\text{Tensile strain in Bar 2 : } \varepsilon_2 = \frac{\Delta L - \alpha_2 \Delta T L}{L}$$

$$\varepsilon_1 + \varepsilon_2 = \frac{\alpha_1 \Delta T L - \Delta L}{L} + \frac{\Delta L - \alpha_2 \Delta T L}{L} = (\alpha_1 - \alpha_2) \Delta T$$

Let σ_1 and σ_2 be the temperature stresses in bars. The above equation can be written as:

$$\frac{\sigma_1}{E_1} + \frac{\sigma_2}{E_2} = (\alpha_1 - \alpha_2) \Delta T$$

In the absence of external forces, for equilibrium, compressive force in Bar 1 = Tensile force in Bar 2. This condition leads to the following relation

$$\sigma_1 A_1 = \sigma_2 A_2$$

Using the above two equations, temperature stresses in both the bars can be computed. This is illustrated in the following example.

Note:

If the temperature of the composite bar is reduced, then a tensile stress will be developed in bar 1 and a compressive stress will be developed in bar 2, since $\alpha_1 > \alpha_2$.

Example 12

A steel flat of 20 mm × 10 mm is fixed with aluminium flat of 20 mm × 10 mm so as to make a square section of 20 mm × 20 mm. The two bars are fastened together at their ends at a temperature of 26°C. Now the temperature of whole assembly is raised to 55°C. Find the stress in each bar. $E_s = 200$ GPa, $E_a = 70$ GPa, $\alpha_s = 11.6 \times 10^{-6}/^\circ\text{C}$, $\alpha_a = 23.2 \times 10^{-6}/^\circ\text{C}$.

- Net temperature rise, $\Delta T = 55 - 26 = 29^\circ\text{C}$.
- Area of Steel flat (A_s) = Area of Aluminium flat (A_a) = $20 \times 10 = 200 \text{ mm}^2$
- For equilibrium, $\sigma_s A_s = \sigma_a A_a$; $\sigma_s = \sigma_a$ will be one of the conditions to be satisfied by the composite assembly.
- But $\frac{\sigma_a}{E_a} + \frac{\sigma_s}{E_s} = (\alpha_a - \alpha_s)\Delta T = (23.2 - 11.6) \times 29 \times 10^{-6} = 0.000336$
- $\frac{\sigma_s}{200000} + \frac{\sigma_a}{70000} = 0.000336$
- $270000 \sigma_s = 4709600$;
- σ_s (tensile) = σ_a (compressive) = 17.44 MPa as $\alpha_a > \alpha_s$

Example 13

A flat steel bar of $20 \text{ mm} \times 8 \text{ mm}$ is placed between two copper bars of $20 \text{ mm} \times 6 \text{ mm}$ each so as to form a composite bar of section of $20 \text{ mm} \times 20 \text{ mm}$. The three bars are fastened together at their ends when the temperature of each is 30°C . Now the temperature of the whole assembly is raised by 30°C . Determine the temperature stress in the steel and copper bars. $E_s = 2E_{cu} = 210 \text{ kN/mm}^2$, $\alpha_s = 11 \times 10^{-6}/^\circ\text{C}$, $\alpha_{cu} = 18 \times 10^{-6}/^\circ\text{C}$.

- Net temperature rise, $\Delta T = 30^\circ\text{C}$.
- Area of Steel flat (A_s) = $20 \times 8 = 160 \text{ mm}^2$
- Area of Copper flats (A_{cu}) = $2 \times 20 \times 6 = 240 \text{ mm}^2$
- For equilibrium, $\sigma_s A_s = \sigma_{cu} A_{cu}$; $\sigma_s = 1.5 \sigma_{cu}$ will be one of the conditions to be satisfied by the composite assembly.
- But $\frac{\sigma_{cu}}{E_{cu}} + \frac{\sigma_s}{E_s} = (\alpha_{cu} - \alpha_s)\Delta T = (18 - 11) \times 30 \times 10^{-6} = 0.00021$
- $\frac{\sigma_{cu}}{105000} + \frac{1.5\sigma_{cu}}{210000} = 0.00021$
- $\sigma_{cu} = 12.6 \text{ MPa}$ (compressive) and $\sigma_s = 18.9 \text{ MPa}$ (tensile) as $\alpha_{cu} > \alpha_s$

1.22 Simple Shear stress and Shear Strain

Consider a rectangular block which is fixed at the bottom and a force F is applied on the top surface as shown in the figure (a) below.

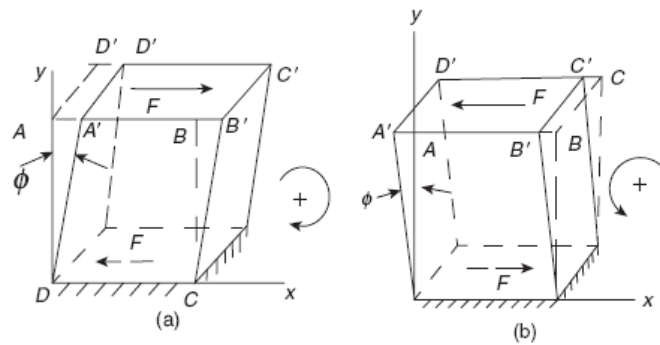

Equal and opposite reaction F develops on the bottom plane and constitutes a couple, *tending to rotate the body in a clockwise direction*. This type of shear force is a *positive shear force* and the shear force per unit surface area on which it acts is called *positive shear stress (τ)*. If force is applied in the opposite direction as shown in Figure (b), then they are termed as negative shear force and shear stress.

The *Shear Strain (ϕ)* = $AA'/AD = \tan\phi$. Since ϕ is a very small quantity, $\tan\phi \approx \phi$. Within the elastic limit, $\tau \propto \phi$ or $\tau = G \phi$

The constant of proportionality G is called *rigidity modulus or shear modulus*.

Note:

Normal stress is computed based on area perpendicular to the surface on which the force is acting, while, the shear stress is computed based on the surface area on which the force is acting. Hence shear stress is also called tangential stress.

1.23 Complementary Shear Stresses

Consider an element ABCD subjected to shear stress (τ) as shown in figure (a). We cannot have equilibrium with merely equal and opposite tangential forces on the faces AB and CD as these forces constitute a couple and induce a turning moment. The statical equilibrium demands that there must be tangential components (τ') along AD and CB such that that can balance the turning moment. These tangential stress (τ') is termed as *complimentary shear stress*.

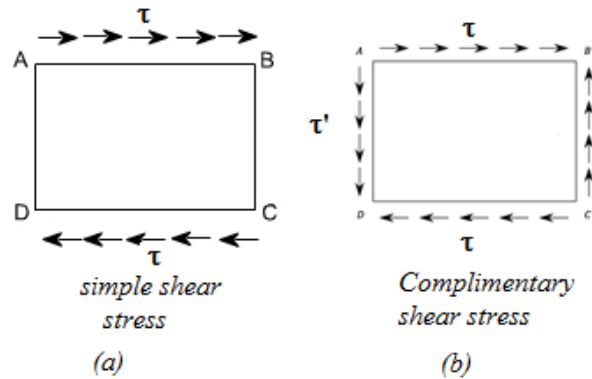

Let t be the thickness of the block. Turning moment due to τ will be $(\tau \times t \times L_{AB}) L_{BC}$ and Turning moment due to τ' will be $(\tau' \times t \times L_{BC}) L_{AB}$. Since these moments have to be equal for equilibrium we have:

$$(\tau \times t \times L_{AB}) L_{BC} = (\tau' \times t \times L_{BC}) L_{AB}$$

From which it follows that $\tau = \tau'$, that is, intensities of shearing stresses across two mutually perpendicular planes are equal.

Example 14

Two 10-mm-thick plates are joined by a single bolt of a diameter of 20 mm. The ultimate shear strength of the material of the bolt = 460 N/mm^2 . Assume factor of safety as 3 and determine the load which can be safely applied on the plates, as shown in figure below. The plates are 50 mm wide.

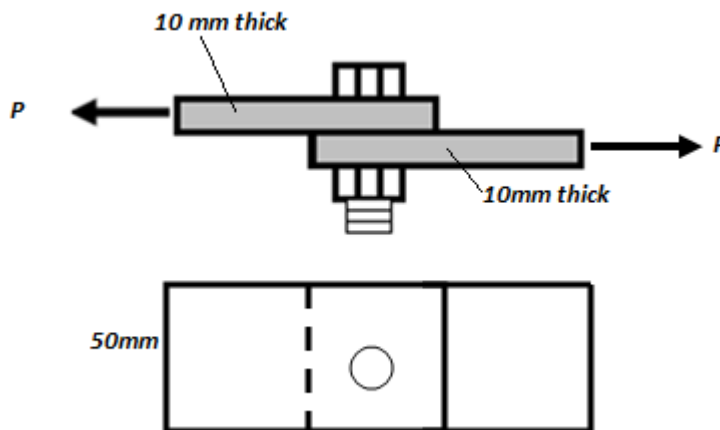

- Ultimate shear strength (τ_u) = 460 MPa
- Allowable shear stress $\tau_a = \tau_u / \text{Factor of safety} = 460 / 3 = 153.3 \text{ MPa}$
- Bolt area $A_b = \pi \times 20^2 / 4 = 314.4 \text{ mm}^2$
- The bolt is subjected to single shear and the permissible load is computed as
- $P = \tau_a \times A_b = 314.4 \times 153.3 / 1000 = \underline{48.2 \text{ kN}}$

1.24 Volumetric strain

This refers to the slight change in the volume of the body resulting from three mutually perpendicular and equal direct stresses as in the case of a body immersed in a liquid under pressure. This is defined as the *ratio of change in volume to the original volume* of the body.

Consider a cube of side 'a' strained so that each side becomes 'a $\pm \delta a$ '.

- Hence the linear strain = $\delta a / a$.
- Change in volume = $(a \pm \delta a)^3 - a^3 = \pm 3a^2 \delta a$. (ignoring small higher order terms)
- Volumetric strain $\epsilon_v = \pm 3a^2 \delta a / a^3 = \pm 3 \delta a / a$
- *The volumetric strain is three times the linear strain*

1.25 Bulk Modulus

This is defined as the ratio of the normal stresses (p) to the volumetric strain (ϵ_v) and denoted by 'K'. Hence $K = p / \epsilon_v$. This is also an elastic constant of the material in addition to E, G and ν .

1.26 Relation between elastic constants

1.26.1 Relation between E, G and ν

Consider a cube of material of side 'a' subjected to the action of the shear and complementary shear stresses and producing the deformed shape as shown in the figure below.

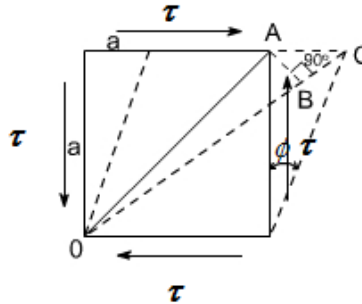

- Since, within elastic limits, the strains are small and the angle ACB may be taken as 45° .
- Since angle between OA and OB is very small hence $OA \approx OB$. BC, is the change in the length of the diagonal OA
- Strain on the diagonal OA = Change in length / original length = BC/OA

$$= AC \cos 45^\circ / (a/\sin 45^\circ) = AC/2a = a \phi / 2 \quad a = \phi / 2$$
- It is found that *strain along the diagonal is numerically half the amount of shear strain.*
- But from definition of rigidity modulus we have, $G = \tau / \phi$
- Hence, Strain on the diagonal OA = $\tau / 2G$

The shear stress system is equivalent or can be replaced by a system of direct stresses at 45° as shown below. One set will be compressive, the other tensile, and both will be equal in value to the applied shear stress.

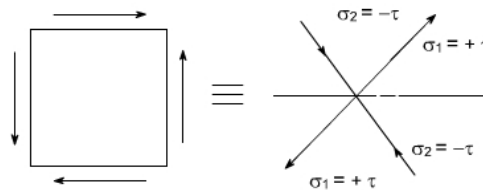

$$\text{Strain in diagonal OA due to direct stresses} = \frac{\sigma_1}{E} - \nu \frac{\sigma_2}{E} = \frac{\tau}{E} + \nu \frac{\tau}{E} = \frac{\tau}{E} (1 + \nu)$$

$$\text{Equating the strain in diagonal OA we have } \frac{\tau}{2G} = \frac{\tau}{E} (1 + \nu)$$

Relation between E,G and ν can be expressed as : $E = 2G(1 + \nu)$

1.26.2 Relation between E,K and ν

Consider a cube subjected to three equal stresses as shown in the figure below.

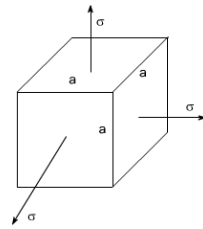

$$\text{Strain in any one direction} = \frac{\sigma}{E} - \nu \frac{\sigma}{E} - \nu \frac{\sigma}{E} = \frac{\sigma}{E} (1 - 2\nu)$$

$$\text{Since the volumetric strain is three times the linear strain: } \epsilon_v = 3 \frac{\sigma}{E} (1 - 2\nu)$$

$$\text{From definition of bulk modulus: } \epsilon_v = \frac{\sigma}{K}$$

$$3 \frac{\sigma}{E} (1 - 2\nu) = \frac{\sigma}{K}$$

Relation between E, K and ν can be expressed as : $E = 3K(1 - 2\nu)$

Note: Theoretically $\nu < 0.5$ as E cannot be zero

1.26.3 Relation between E, G and K

We have $E = 2G(1+\nu)$ from which $\nu = (E - 2G) / 2G$

We have $E = 3K(1-2\nu)$ from which $\nu = (3K - E) / 6K$

$$(E - 2G) / 2G = (3K - E) / 6K \text{ or } (6EK - 12GK) = (6GK - 2EG) \text{ or } 6EK + 2EG = (6GK + 12GK)$$

Relation between E, G and K can be expressed as: $E = \frac{9GK}{(3K+G)}$

1.27 Exercise problems

1. A steel bar of a diameter of 20 mm and a length of 400 mm is subjected to a tensile force of 40 kN. Determine (a) the tensile stress and (b) the axial strain developed in the bar if the Young's modulus of steel $E = 200 \text{ kN/mm}^2$

Answer: (a) Tensile stress = 127.23MPa, (b) Axial strain = 0.00064

2. A 100mm long bar is subjected to a compressive force such that the stress developed in the bar is 50 MPa. (a) If the diameter of the bar is 15 mm, what is the axial compressive force? (b) If E for bar is 105 kN/mm^2 , what is the axial strain in the bar?

Answer: (a) Compressive force = 8.835 kN, (b) Axial strain = 0.00048

3. A steel bar of square section $30 \times 30 \text{ mm}$ and a length of 600 mm is subjected to an axial tensile force of 135 kN. Determine the changes in dimensions of the bar. $E = 200 \text{ kN/mm}^2$, $\nu = 0.3$.

Answer: Increase in length $\delta l = 0.45 \text{ mm}$, Decrease in breadth $\delta b = 6.75 \times 10^{-3} \text{ mm}$,

4. A stepped circular steel bar of a length of 150 mm with diameters 20, 15 and 10 mm along lengths 40, 50 and 65 mm, respectively, subjected to various forces is shown in figure below. If $E = 200 \text{ kN/mm}^2$, determine the total change in its length.

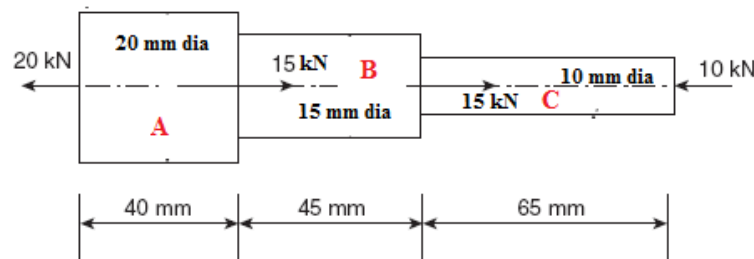

Answer : Total decrease in length = 0.022mm

5. A stepped bar is subjected to axial loads as shown in the figure below. If $E = 200 \text{ GPa}$, calculate the stresses in each portion AB , BC and CD . What is the total change in length of the bar?

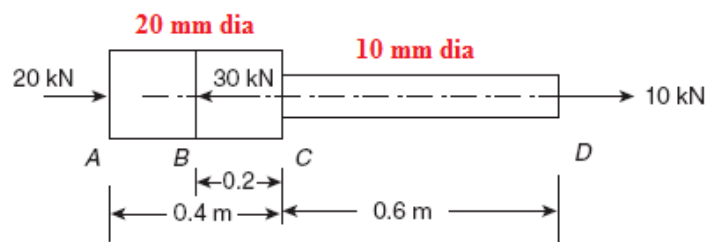

Answer: Total increase in length = 0.35mm

6. A 400-mm-long aluminium bar uniformly tapers from a diameter of 25 mm to a diameter of 15 mm. It is subjected to an axial tensile load such that stress at middle section is 60 MPa. What is the load applied and what is the total change in the length of the bar if $E = 67,000 \text{ MPa}$? (Hint: At the middle diameter = $(25+15)/2 = 20 \text{ mm}$).

Answer: Load = 18.85kN, Increase in length = 0.382 mm

7. A short concrete column of 250 mm × 250 mm in section strengthened by four steel bars near the corners of the cross-section. The diameter of each steel bar is 30 mm. The column is subjected to an axial compressive load of 250 kN. Find the stresses in the steel and the concrete. $E_s = 15 E_c = 210 \text{ GPa}$. If the stress in the concrete is not to exceed 2.1 N/mm^2 , what area of the steel bar is required in order that the column may support a load of 350 kN?
Answer: Stress in concrete = 2.45 N/mm^2 , Stress in steel = 36.75 N/mm^2 , Area of steel = 7440 mm^2
8. Two aluminium strips are rigidly fixed to a steel strip of section 25 mm × 8 mm and 1 m long. The aluminium strips are 0.5 m long each with section 25 mm × 5 mm. The composite bar is subjected to a tensile force of 10 kN as shown in the figure below. Determine the deformation of point B. $E_s = 3E_A = 210 \text{ kN/mm}^2$. *Answer: 0.203 mm*
(Hint: Portion CB is a single bar, Portion AC is a composite bar. Compute elongation separately for both the portions and add)

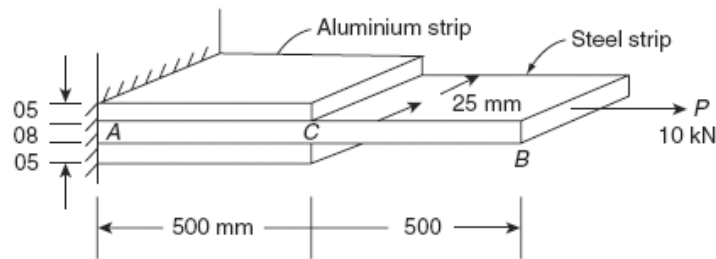

1.28 Summary

1. The *strength* of a structural component is its ability to withstand applied forces without *failure* and this depends upon the *sectional dimensions and material characteristics*.
2. *Stiffness* influences the deformation as a consequence of *stretching, shortening, bending, sliding, buckling, twisting and warping* due to applied forces. Such deformations also depend upon *sectional dimensions, length and material characteristics*.
3. *Stability* refers to the ability to maintain its original configuration. This again depends upon *sectional dimensions, length and material characteristics*.
4. If the *internal forces* are distributed *uniformly* and the bar is said to be subjected to a *uniform direct or normal or simple stress*. $\sigma = P/A$ expressed as N/mm^2 or MPa.
5. *Longitudinal Strain* $\epsilon = \delta L / L$. It has no units. Expressed as microstrain $\mu\epsilon$ or percentage strain $\epsilon(\%)$.
6. *Hooke's law* : σ is proportional to ϵ

7. *Modulus of elasticity or Young's modulus* : $E = \sigma/\epsilon = P L/ A \delta L$. This is determined by conducting tension or compression test on specimens in the laboratory
8. *Yield strength* of the material corresponds to the load carrying capacity.
9. The capacity of a material to allow these large plastic deformations is a measure of *ductility* of the material.
10. The nominal stress at failure, termed the *maximum or ultimate tensile stress*, is given by the ultimate load divided by the original cross-sectional area of the bar.
11. In some cases yield point may not exist at all. In such cases a *proof stress* is used to indicate the onset of plastic strain.
12. *Factor of safety* = *Yield stress or Proof stress / Allowable working stress*
13. *% Elongation* = *(Increase in gauge length at fracture / Original gauge length)100*
14. *% reduction in area* = *(Cross sectional area of necked portion / Original gauge length)100*
15. There is little or no necking at fracture for *brittle materials*.
16. Within the elastic range the ratio of the lateral and longitudinal strains will always be constant. This ratio is termed *Poisson's ratio (ν)* and is in the range of *0.25 and 0.33*.
17. Elongation of tapering bars of circular cross section $\delta L = \frac{4P L}{\pi E d_1 d_2}$
18. Elongation of tapering bars of rectangular cross section $\delta L = [P L/ (E T (B-b))] \ln (B/b)$
19. Elongation in Bar Due to Self-Weight $\delta L = W L/ 2 A E$
20. St.Venant's Principle states that the assumption of uniform stress is valid in regions away from the point of application of load.
21. A composite bar can be made of two bars of different materials rigidly fixed together so that both bars strain together under external load. As the strains in the two bars are same, the stresses in the two bars will be different and depend on their respective modulus of elasticity. A stiffer bar will share major part of external load.
22. Load carrying capacity of a composite bar is given by

$$P = \sigma_H \frac{E_S}{E_H} A_S + \sigma_H A_H = \sigma_H (A_H + \frac{E_S}{E_H} A_S)$$

-
23. Free thermal expansion in the bar = $\alpha \Delta T L$
24. The compressive strain in the bar due to temperature rise = $\alpha \Delta T L / L = \alpha \Delta T$
25. Compressive stress due to temperature rise = $\alpha \Delta T E$
26. The bar can buckle due to large compressive forces generated in the bar due to temperature increase or may fracture due to large tensile forces generated due to temperature decrease.
27. Normal stress is computed based on area perpendicular to the surface on which the force is acting, while, the shear stress is computed based on the surface area on which the force is acting. Hence shear stress is also called tangential stress.
28. The constant of proportionality between shear stress (τ) and shear strain (ϕ) **G** is called *rigidity modulus or shear modulus*.
29. The tangential stress introduced from equilibrium consideration is termed as *complimentary shear stress*. Intensities of shearing stresses across two mutually perpendicular planes are equal.
30. *Volumetric strain* is defined as *the ratio of change in volume to the original volume* of the body.
31. **$E = 2G(1 + \nu)$**
32. **$E = 3K(1 - 2\nu)$**
33. **$E = \frac{9GK}{(3K+G)}$**