

## **Introduction**

The subject Machine Design is the creation of new and better machines and improving the existing ones. A new or better machine is one which is more economical in the overall cost of production and operation. The process of design is a long and time consuming one. From the study of existing ideas, a new idea has to be conceived. The idea is then studied keeping in mind its commercial success and given shape and form in the form of drawings. In the preparation of these drawings, care must be taken of the availability of resources in money, in men and in materials required for the successful completion of the new idea into an actual reality. In designing a machine component, it is necessary to have a good knowledge of many subjects such as Mathematics, Engineering Mechanics, Strength of Materials, Theory of Machines, Workshop Processes and Engineering Drawing.

## **Classifications of Machine Design**

The machine design may be classified as follows:

**1. Adaptive design.** In most cases, the designer's work is concerned with adaptation of existing designs. This type of design needs no special knowledge or skill and can be attempted by designers of ordinary technical training. The designer only makes minor alternation or modification in the existing designs of the product.

**2. Development design.** This type of design needs considerable scientific training and design ability in order to modify the existing designs into a new idea by adopting a new material or different method of manufacture. In this case, though the designer starts from the existing design, but the final product may differ quite markedly from the original product.

**3. New design.** This type of design needs lot of research, technical ability and creative thinking. Only those designers who have personal qualities of a sufficiently high order can take up the work of a new design. The designs, depending upon the methods used, may be classified as follows:

**(a) Rational design.** This type of design depends upon mathematical formulae of principle of mechanics.

**(b) Empirical design.** This type of design depends upon empirical formulae based on the practice and past experience.

**(c) Industrial design.** This type of design depends upon the production aspects to manufacture any machine component in the industry.

(d) **Optimum design.** It is the best design for the given objective function under the specified constraints. It may be achieved by minimising the undesirable effects.

(e) **System design.** It is the design of any complex mechanical system like a motor car.

(f) **Element design.** It is the design of any element of the mechanical system like piston, crankshaft, connecting rod, etc.

(g) **Computer aided design.** This type of design depends upon the use of computer systems to assist in the creation, modification, analysis and optimisation of a design.

### **General Considerations in Machine Design**

Following are the general considerations in designing a machine component:

**1. Type of load and stresses caused by the load.** The load, on a machine component, may act in several ways due to which the internal stresses are set up. The various types of load and stresses are discussed later.

**2. Motion of the parts or kinematics of the machine.** The successful operation of any machine depends largely upon the simplest arrangement of the parts which will give the motion required.

The motion of the parts may be:

(a) Rectilinear motion which includes unidirectional and reciprocating motions.

(b) Curvilinear motion which includes rotary, oscillatory and simple harmonic.

(c) Constant velocity.

(d) Constant or variable acceleration.

**3. Selection of materials.** It is essential that a designer should have a thorough knowledge of the properties of the materials and their behaviour under working conditions. Some of the important characteristics of materials are: strength, durability, flexibility, weight, resistance to heat and corrosion, ability to cast, welded or hardened, machinability, electrical conductivity, etc. The various types of engineering materials and their properties are discussed later.

**4. Form and size of the parts.** The form and size are based on judgment. The smallest practicable cross-section may be used, but it may be checked that the stresses induced in the designed cross-section are reasonably safe. In order to design any machine part for form and

size, it is necessary to know the forces which the part must sustain. It is also important to anticipate any suddenly applied or impact load which may cause failure.

**5. Frictional resistance and lubrication.** There is always a loss of power due to frictional resistance and it should be noted that the friction of starting is higher than that of running friction. It is, therefore, essential that a careful attention must be given to the matter of lubrication of all surfaces which move in contact with others, whether in rotating, sliding, or rolling bearings.

**6. Convenient and economical features.** In designing, the operating features of the machine should be carefully studied. The starting, controlling and stopping levers should be located on the basis of convenient handling. The adjustment for wear must be provided employing the various take up devices and arranging them so that the alignment of parts is preserved. If parts are to be changed for different products or replaced on account of wear or breakage, easy access should be provided and the necessity of removing other parts to accomplish this should be avoided if possible. The economical operation of a machine which is to be used for production or for the processing of material should be studied, in order to learn whether it has the maximum capacity consistent with the production of good work.

**7. Use of standard parts.** The use of standard parts is closely related to cost, because the cost of standard or stock parts is only a fraction of the cost of similar parts made to order. The standard or stock parts should be used whenever possible; parts for which patterns are already in existence such as gears, pulleys and bearings and parts which may be selected from regular shop stock such as screws, nuts and pins. Bolts and studs should be as few as possible to avoid the delay caused by changing drills, reamers and taps and also to decrease the number of wrenches required.

**8. Safety of operation.** Some machines are dangerous to operate, especially those which are speeded up to insure production at a maximum rate. Therefore, any moving part of a machine which is within the zone of a worker is considered an accident hazard and may be the cause of an injury. It is, therefore, necessary that a designer should always provide safety devices for the safety of the operator. The safety appliances should in no way interfere with operation of the machine.

**9. Workshop facilities.** A design engineer should be familiar with the limitations of this employer's workshop, in order to avoid the necessity of having work done in some other workshop. It is sometimes necessary to plan and supervise the workshop operations and to draft methods for casting, handling and machining special parts.

**10. Number of machines to be manufactured.** The number of articles or machines to be manufactured affects the design in a number of ways. The engineering and shop costs which are called fixed charges or overhead expenses are distributed over the number of articles to be manufactured. If only a few articles are to be made, extra expenses are not justified unless the machine is large or of some special design. An order calling for small number of the product will not permit any undue expense in the workshop processes, so that the designer should restrict his specification to standard parts as much as possible.

**11. Cost of construction.** The cost of construction of an article is the most important consideration involved in design. In some cases, it is quite possible that the high cost of an article may immediately bar it from further considerations. If an article has been invented and tests of handmade samples have shown that it has commercial value, it is then possible to justify the expenditure of a considerable sum of money in the design and development of automatic machines to produce the article, especially if it can be sold in large numbers. The aim of design engineer under all conditions should be to reduce the manufacturing cost to the minimum.

**12. Assembling.** Every machine or structure must be assembled as a unit before it can function. Large units must often be assembled in the shop, tested and then taken to be transported to their place of service. The final location of any machine is important and the design engineer must anticipate the exact location and the local facilities for erection.

### **General Procedure in Machine Design**

In designing a machine component, there is no rigid rule. The problem may be attempted in several ways. However, the general procedure to solve a design problem is as follows:

## Lecture Notes – 1

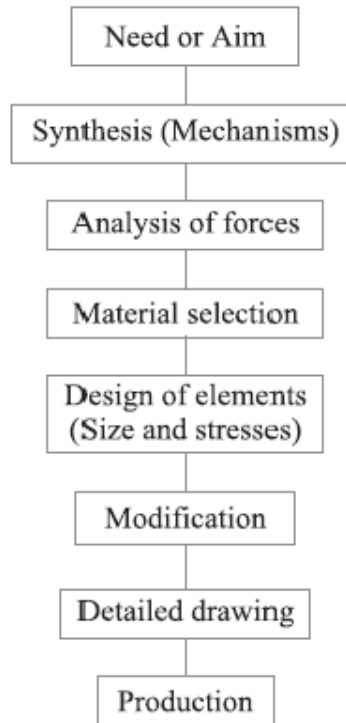

Fig.1. General Machine Design Procedure

**1. Recognition of need.** First of all, make a complete statement of the problem, indicating the need, aim or purpose for which the machine is to be designed.

**2. Synthesis (Mechanisms).** Select the possible mechanism or group of mechanisms which will give the desired motion.

**3. Analysis of forces.** Find the forces acting on each member of the machine and the energy transmitted by each member.

**4. Material selection.** Select the material best suited for each member of the machine.

**5. Design of elements (Size and Stresses).** Find the size of each member of the machine by considering the force acting on the member and the permissible stresses for the material used. It should be kept in mind that each member should not deflect or deform than the permissible limit.

**6. Modification.** Modify the size of the member to agree with the past experience and judgment to facilitate manufacture. The modification may also be necessary by consideration of manufacturing to reduce overall cost.

**7. Detailed drawing.** Draw the detailed drawing of each component and the assembly of the machine with complete specification for the manufacturing processes suggested.

**8. Production.** The component, as per the drawing, is manufactured in the workshop.

The flow chart for the general procedure in machine design is shown in Fig.

**Note:** When there are number of components in the market having the same qualities of efficiency, durability and cost, then the customer will naturally attract towards the most appealing product. The aesthetic and ergonomics are very important features which gives grace and lustre to product and dominates the market.

### Engineering materials and their properties

The knowledge of materials and their properties is of great significance for a design engineer. The machine elements should be made of such a material which has properties suitable for the conditions of operation. In addition to this, a design engineer must be familiar with the effects which the manufacturing processes and heat treatment have on the properties of the materials. Now, we shall discuss the commonly used engineering materials and their properties in Machine Design.

### Classification of Engineering Materials

The engineering materials are mainly classified as:

1. Metals and their alloys, such as iron, steel, copper, aluminum, etc.
2. Non-metals, such as glass, rubber, plastic, etc.

The metals may be further classified as:

- (a) Ferrous metals and (b) Non-ferrous metals.

The *ferrous metals* are those which have the iron as their main constituent, such as cast iron, wrought iron and steel.

The *non-ferrous* metals are those which have a metal other than iron as their main constituent, such as copper, aluminum, brass, tin, zinc, etc.

### Selection of Materials for Engineering Purposes

The selection of a proper material, for engineering purposes, is one of the most difficult problems for the designer. The best material is one which serves the desired objective at the minimum cost. The following factors should be considered while selecting the material:

1. Availability of the materials,
2. Suitability of the materials for the working conditions in service, and
3. The cost of the materials.

The important properties, which determine the utility of the material, are physical, chemical and mechanical properties. We shall now discuss the physical and mechanical properties of the material in the following articles.

### Physical Properties of Metals

The physical properties of the metals include luster, colour, size and shape, density, electric and thermal conductivity, and melting point. The following table shows the important physical properties of some pure metals.

### Mechanical Properties of Metals

The mechanical properties of the metals are those which are associated with the ability of the material to resist mechanical forces and load. These mechanical properties of the metal include strength, stiffness, elasticity, plasticity, ductility, brittleness, malleability, toughness, resilience, creep and hardness. We shall now discuss these properties as follows:

1. **Strength.** It is the ability of a material to resist the externally applied forces without breaking or yielding. The internal resistance offered by a part to an externally applied force is called stress.
2. **Stiffness.** It is the ability of a material to resist deformation under stress. The modulus of elasticity is the measure of stiffness.

**3. Elasticity.** It is the property of a material to regain its original shape after deformation when the external forces are removed. This property is desirable for materials used in tools and machines. It may be noted that steel is more elastic than rubber.

**4. Plasticity.** It is property of a material which retains the deformation produced under load permanently. This property of the material is necessary for forgings, in stamping images on coins and in ornamental work.

**5. Ductility.** It is the property of a material enabling it to be drawn into wire with the application of a tensile force. A ductile material must be both strong and plastic. The ductility is usually measured by the terms, percentage elongation and percentage reduction in area. The ductile material commonly used in engineering practice (in order of diminishing ductility) are mild steel, copper, aluminium, nickel, zinc, tin and lead.

**6. Brittleness.** It is the property of a material opposite to ductility. It is the property of breaking of a material with little permanent distortion. Brittle materials when subjected to tensile loads snap off without giving any sensible elongation. Cast iron is a brittle material.

**7. Malleability.** It is a special case of ductility which permits materials to be rolled or hammered into thin sheets. A malleable material should be plastic but it is not essential to be so strong. The malleable materials commonly used in engineering practice (in order of diminishing malleability) are lead, soft steel, wrought iron, copper and aluminium.

**8. Toughness.** It is the property of a material to resist fracture due to high impact loads like hammer blows. The toughness of the material decreases when it is heated. It is measured by the amount of energy that a unit volume of the material has absorbed after being stressed upto the point of fracture. This property is desirable in parts subjected to shock and impact loads.

**9. Machinability.** It is the property of a material which refers to a relative ease with which a material can be cut. The machinability of a material can be measured in a number of ways such as comparing the tool life for cutting different materials or thrust required to remove the material at some given rate or the energy required to remove a unit volume of the material. It may be noted that brass can be easily machined than steel.



**10. Resilience.** It is the property of a material to absorb energy and to resist shock and impact loads. It is measured by the amount of energy absorbed per unit volume within elastic limit. This property is essential for spring materials.

**11. Creep.** When a part is subjected to a constant stress at high temperature for a long period of time, it will undergo a slow and permanent deformation called **creep**. This property is considered in designing internal combustion engines, boilers and turbines.

**12. Fatigue.** When a material is subjected to repeated stresses, it fails at stresses below the yield point stresses. Such type of failure of a material is known as **\*fatigue**. The failure is caused by means of a progressive crack formation which are usually fine and of microscopic size. This property is considered in designing shafts, connecting rods, springs, gears, etc.

**13. Hardness.** It is a very important property of the metals and has a wide variety of meanings. It embraces many different properties such as resistance to wear, scratching, deformation and machinability etc. It also means the ability of a metal to cut another metal. The hardness is usually expressed in numbers which are dependent on the method of making the test. The hardness of a metal may be determined by the following tests:

- (a) Brinell hardness test,
- (b) Rockwell hardness test,
- (c) Vickers hardness (also called Diamond Pyramid) test, and
- (d) Shore scleroscope.

### Steel

It is an alloy of iron and carbon, with carbon content up to a maximum of 1.5%. The carbon occurs in the form of iron carbide, because of its ability to increase the hardness and strength of the steel. Other elements *e.g.* silicon, sulphur, phosphorus and manganese are also present to greater or lesser amount to impart certain desired properties to it. Most of the steel produced now-a-days is **plain carbon steel** or simply **carbon steel**. A carbon steel is defined as a steel which has its properties mainly due to its carbon content and does not contain more than 0.5% of silicon and 1.5% of manganese.

The plain carbon steels varying from 0.06% carbon to 1.5% carbon are divided into the following types depending upon the carbon content.

1. Dead mild steel — up to 0.15% carbon

2. Low carbon or mild steel — 0.15% to 0.45% carbon

3. Medium carbon steel — 0.45% to 0.8% carbon

4. High carbon steel — 0.8% to 1.5% carbon

According to Indian standard \*[IS: 1762 (Part-I)–1974], a new system of designating the steel is recommended. According to this standard, steels are designated on the following two basis: (a) On the basis of mechanical properties, and (b) On the basis of chemical composition. We shall now discuss, in detail, the designation of steel on the above two basis, in the following pages.

### **Steels Designated on the Basis of Mechanical Properties**

These steels are carbon and low alloy steels where the main criterion in the selection and inspection of steel is the tensile strength or yield stress. According to Indian standard IS: 1570 (Part-I)- 1978 (Reaffirmed 1993), these steels are designated by a symbol 'Fe' or 'Fe E' depending on whether the steel has been specified on the basis of minimum tensile strength or yield strength, followed by the figure indicating the minimum tensile strength or yield stress in N/mm<sup>2</sup>. For example 'Fe 290' means a steel having minimum tensile strength of 290 N/mm<sup>2</sup> and 'Fe E 220' means a steel having yield strength of 220 N/mm<sup>2</sup>.

### **Steels Designated on the Basis of Chemical Composition**

According to Indian standard, IS : 1570 (Part II/Sec I)-1979 (Reaffirmed 1991), the carbon steels are designated in the following order :

(a) Figure indicating 100 times the average percentage of carbon content,

(b) Letter 'C', and

(c) Figure indicating 10 times the average percentage of manganese content. The figure after multiplying shall be rounded off to the nearest integer.

For example 20C8 means a carbon steel containing 0.15 to 0.25 per cent (0.2 per cent on average) carbon and 0.60 to 0.90 per cent (0.75 per cent rounded off to 0.8 per cent on an average) manganese.

### **Effect of Impurities on Steel**

The following are the effects of impurities like silicon, sulphur, manganese and phosphorus on steel.

1. **Silicon.** The amount of silicon in the finished steel usually ranges from 0.05 to 0.30%. Silicon is added in low carbon steels to prevent them from becoming porous. It removes the gases and oxides, prevent blow holes and thereby makes the steel tougher and harder.

2. **Sulphur.** It occurs in steel either as iron sulphide or manganese sulphide. Iron sulphide because of its low melting point produces red shortness, whereas manganese sulphide does not affect so much. Therefore, manganese sulphide is less objectionable in steel than iron sulphide.

3. **Manganese.** It serves as a valuable deoxidising and purifying agent in steel. Manganese also combines with sulphur and thereby decreases the harmful effect of this element remaining in the steel. When used in ordinary low carbon steels, manganese makes the metal ductile and of good bending qualities. In high speed steels, it is used to toughen the metal and to increase its critical temperature.

4. **Phosphorus.** It makes the steel brittle. It also produces cold shortness in steel. In low carbon steels, it raises the yield point and improves the resistance to atmospheric corrosion. The sum of carbon and phosphorus usually does not exceed 0.25%.

#### **References:**

1. Machine Design - V.Bandari .
2. Machine Design – R.S. Khurmi
3. Design Data hand Book - S MD Jalaludin.

**Manufacturing considerations in Machine design****Manufacturing Processes**

The knowledge of manufacturing processes is of great importance for a design engineer. The following are the various manufacturing processes used in Mechanical Engineering.

**1. Primary shaping processes.** The processes used for the preliminary shaping of the machine component are known as primary shaping processes. The common operations used for this process are casting, forging, extruding, rolling, drawing, bending, shearing, spinning, powder metal forming, squeezing, etc.

**2. Machining processes.** The processes used for giving final shape to the machine component, according to planned dimensions are known as machining processes. The common operations used for this process are turning, planning, shaping, drilling, boring, reaming, sawing, broaching, milling, grinding, hobbing, etc.

**3. Surface finishing processes.** The processes used to provide a good surface finish for the machine component are known as surface finishing processes. The common operations used for this process are polishing, buffing, honing, lapping, abrasive belt grinding, barrel tumbling, electroplating, super finishing, sheradizing, etc.

**4. Joining processes.** The processes used for joining machine components are known as joining processes. The common operations used for this process are welding, riveting, soldering, brazing, screw fastening, pressing, sintering, etc.

**5. Processes effecting change in properties.** These processes are used to impart certain specific properties to the machine components so as to make them suitable for particular operations or uses. Such processes are heat treatment, hot-working, cold-working and shot peening.

**Other considerations in Machine design**

1. Workshop facilities.
2. Number of machines to be manufactured
3. Cost of construction

## 4. Assembling

**Interchangeability**

The term interchangeability is normally employed for the mass production of identical items within the prescribed limits of sizes. A little consideration will show that in order to maintain the sizes of the part within a close degree of accuracy, a lot of time is required. But even then there will be small variations. If the variations are within certain limits, all parts of equivalent size will be equally fit for operating in machines and mechanisms. Therefore, certain variations are recognized and allowed in the sizes of the mating parts to give the required fitting. This facilitates to select at random from a large number of parts for an assembly and results in a considerable saving in the cost of production.

In order to control the size of finished part, with due allowance for error, for interchangeable parts is called *limit system*. It may be noted that when an assembly is made of two parts, the part which enters into the other, is known as *enveloped surface* (or *shaft* for cylindrical part) and the other in which one enters is called *enveloping surface* (or *hole* for cylindrical part). The term *shaft* refers not only to the diameter of a circular shaft, but it is also used to designate any external dimension of a part. The term *hole* refers not only to the diameter of a circular hole, but it is also used to designate any internal dimension of a part.

**Important Terms used in Limit System**

The following terms used in limit system (or interchangeable system) are important from the subject point of view:

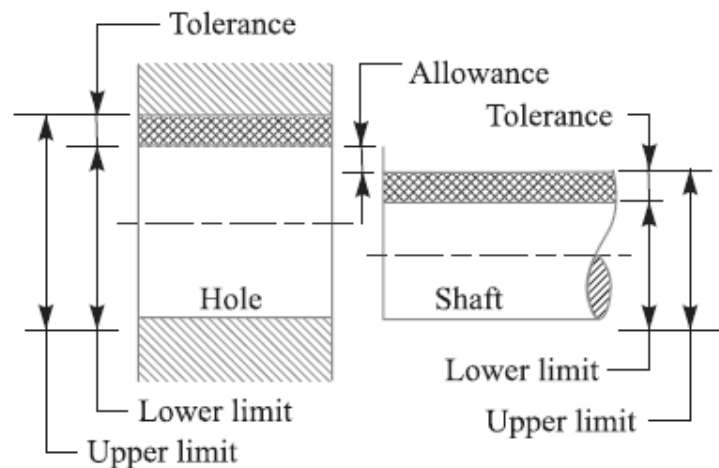

Fig. Limits of sizes.

1. **Nominal size.** It is the size of a part specified in the drawing as a matter of convenience.
2. **Basic size.** It is the size of a part to which all limits of variation (i.e. tolerances) are applied to arrive at final dimensioning of the mating parts. The nominal or basic size of a part is often the same.
3. **Actual size.** It is the actual measured dimension of the part. The difference between the basic size and the actual size should not exceed a certain limit; otherwise it will interfere with the interchangeability of the mating parts.
4. **Limits of sizes.** There are two extreme permissible sizes for a dimension of the part as shown in Fig. The largest permissible size for a dimension of the part is called **upper** or **high** or **maximum limit**, whereas the smallest size of the part is known as **lower** or **minimum limit**.
5. **Allowance.** It is the difference between the basic dimensions of the mating parts. The allowance may be **positive** or **negative**. When the shaft size is less than the hole size, then the allowance is **positive** and when the shaft size is greater than the hole size, then the allowance is **negative**.



Fig. Method of assigning Tolerances

6. **Tolerance.** It is the difference between the upper limit and lower limit of a dimension. In other words, it is the maximum permissible variation in a dimension. The tolerance may be **unilateral** or **bilateral**. When all the tolerance is allowed on one side of the nominal size, e.g.  $20^{+0.000}_{-0.004}$ , then it is said to be **unilateral system of tolerance**. The unilateral system is mostly used in industries as it permits changing the tolerance value while still retaining the same

allowance or type of fit. When the tolerance is allowed on both sides of the nominal size, e.g.

$20^{+0.002}_{-0.002}$ , then it is said to be **bilateral system of tolerance**. In this case + 0.002 is the upper limit and – 0.002 is the lower limit.

**7. Tolerance zone.** It is the zone between the maximum and minimum limit size.

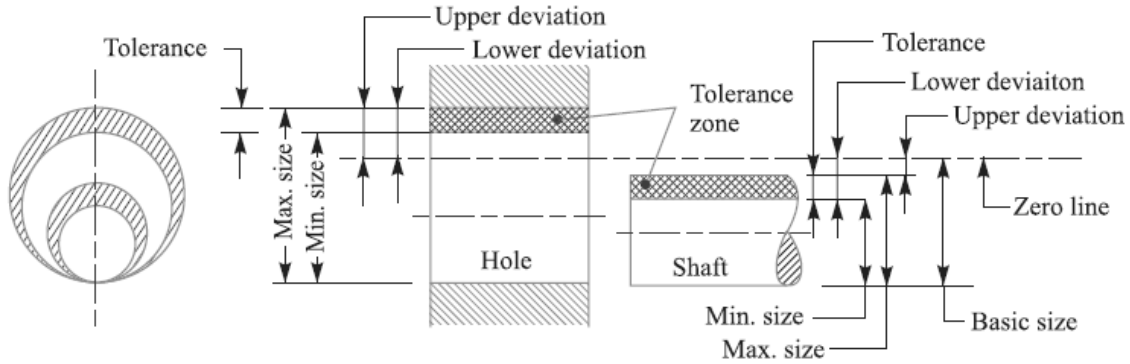

Fig. Tolerance Zone

**8. Zero line.** It is a straight line corresponding to the basic size. The deviations are measured from this line. The positive and negative deviations are shown above and below the zero line respectively.

**9. Upper deviation.** It is the algebraic difference between the maximum size and the basic size. The upper deviation of a hole is represented by a symbol ES (Ecart Superior) and of a shaft, it is represented by es.

**10. Lower deviation.** It is the algebraic difference between the minimum size and the basic size. The lower deviation of a hole is represented by a symbol EI (Ecart Inferior) and of a shaft, it is represented by ei.

**11. Actual deviation.** It is the algebraic difference between an actual size and the corresponding basic size.

**12. Mean deviation.** It is the arithmetical mean between the upper and lower deviations.

**13. Fundamental deviation.** It is one of the two deviations which are conventionally chosen to define the position of the tolerance zone in relation to zero line, as shown in Fig.

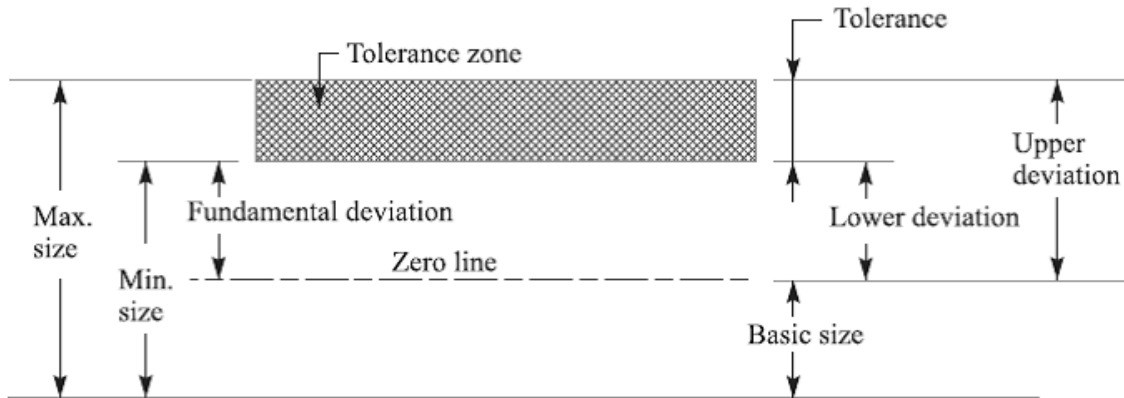

Fig. Fundamental deviation.

**Fits**

The degree of tightness or looseness between the two mating parts is known as a *fit* of the parts. The nature of fit is characterized by the presence and size of clearance and interference. The *clearance* is the amount by which the actual size of the shaft is less than the actual size of the mating hole in an assembly as shown in Fig. 3.5 (a). In other words, the clearance is the difference between the sizes of the hole and the shaft before assembly. The difference must be *positive*.

The *clearance* is the amount by which the actual size of the shaft is less than the actual size of the mating hole in an assembly as shown in Fig. (a). In other words, the clearance is the difference between the sizes of the hole and the shaft before assembly. The difference must be *positive*.

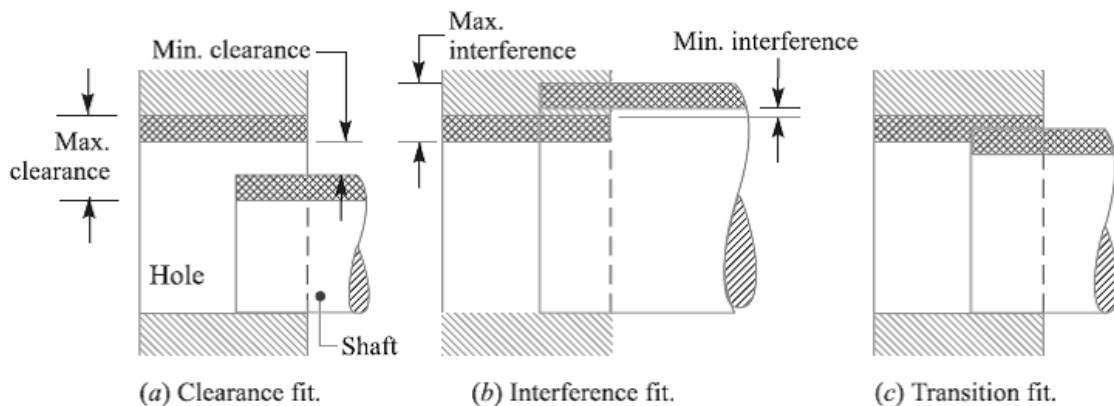

Fig. Types of fits.

The *interference* is the amount by which the actual size of a shaft is larger than the actual finished size of the mating hole in an assembly as shown in Fig. (b). In other words, the



interference is the arithmetical difference between the sizes of the hole and the shaft, before assembly. The difference must be *negative*.

### Types of Fits

According to Indian standards, the fits are classified into the following three groups:

**1. Clearance fit.** In this type of fit, the size limits for mating parts are so selected that clearance between them always occur, as shown in Fig. (a). It may be noted that in a clearance fit, the tolerance zone of the hole is entirely above the tolerance zone of the shaft. In a clearance fit, the difference between the minimum size of the hole and the maximum size of the shaft is known as *minimum clearance* whereas the difference between the maximum size of the hole and minimum size of the shaft is called *maximum clearance* as shown in Fig. (a). The clearance fits may be slide fit, easy sliding fit, running fit, slack running fit and loose running fit.

**2. Interference fit.** In this type of fit, the size limits for the mating parts are so selected that interference between them always occur, as shown in Fig. (b). It may be noted that in an interference fit, the tolerance zone of the hole is entirely below the tolerance zone of the shaft. In an interference fit, the difference between the maximum size of the hole and the minimum size of the shaft is known as *minimum interference*, whereas the difference between the minimum size of the hole and the maximum size of the shaft is called *maximum interference*, as shown in Fig. (b).

The interference fits may be shrink fit, heavy drive fit and light drive fit.

**3. Transition fit.** In this type of fit, the size limits for the mating parts are so selected that either a clearance or interference may occur depending upon the actual size of the mating parts, as shown in Fig. (c). It may be noted that in a transition fit, the tolerance zones of hole and shaft overlap. The transition fits may be force fit, tight fit and push fit.

### Basis of Limit System

The following are two bases of limit system:

**1. Hole basis system.** When the hole is kept as a constant member (*i.e.* when the lower deviation of the hole is zero) and different fits are obtained by varying the shaft size, as shown in Fig. (a), then the limit system is said to be on a hole basis.

**2. Shaft basis system.** When the shaft is kept as a constant member (*i.e.* when the upper deviation of the shaft is zero) and different fits are obtained by varying the hole size, as shown in Fig.(b), Then the limit system is said to be on a shaft basis.

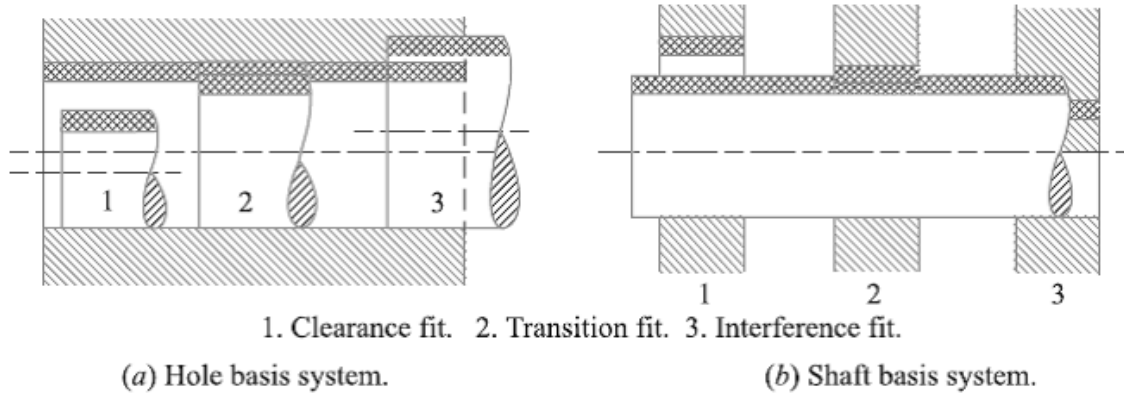

Fig. Bases of Limit System.

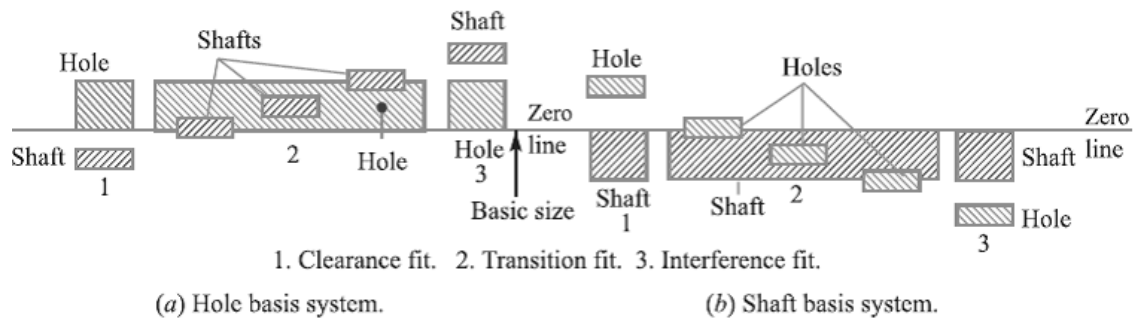

Fig. Bases of Limit System

The hole basis and shaft basis system may also be shown as in Fig. with respect to the zero line. It may be noted that from the manufacturing point of view, a hole basis system is always preferred. This is because the holes are usually produced and finished by standard tooling like drill, reamers, etc., whose size is not adjustable easily. On the other hand, the size of the shaft (which is to go into the hole) can be easily adjusted and is obtained by turning or grinding operations.

**References:**

1. Machine Design - V.Bandari .
2. Machine Design – R.S. Khurmi
3. Design Data hand Book - S MD Jalaludin.

**Problem-1:**

The dimensions of the mating parts, according to basic hole system, are given as follows:

Hole : 25.00 mm                      Shaft : 24.97 mm  
          25.02 mm                      24.95 mm

Find the hole tolerance, shaft tolerance and allowance.

**Solution.** Given : Lower limit of hole = 25 mm ; Upper limit of hole = 25.02 mm ;  
 Upper limit of shaft = 24.97 mm ; Lower limit of shaft = 24.95 mm

*Hole tolerance*

We know that hole tolerance

$$= \text{Upper limit of hole} - \text{Lower limit of hole}$$

$$= 25.02 - 25 = 0.02 \text{ mm Ans.}$$

*Shaft tolerance*

We know that shaft tolerance

$$= \text{Upper limit of shaft} - \text{Lower limit of shaft}$$

$$= 24.97 - 24.95 = 0.02 \text{ mm Ans.}$$

*Allowance*

We know that allowance

$$= \text{Lower limit of hole} - \text{Upper limit of shaft}$$

$$= 25.00 - 24.97 = 0.03 \text{ mm Ans.}$$

**Problem-2:**

Calculate the tolerances, fundamental deviations and limits of sizes for the shaft designated as 40 H8 / f7.

**Solution.** Given: Shaft designation = 40 H8 / f7

The shaft designation 40 H8 / f7 means that the basic size is 40 mm and the tolerance grade for the hole is 8 (*i.e.* IT 8) and for the shaft is 7 (*i.e.* IT 7).

*Tolerances*

Since 40 mm lies in the diameter steps of 30 to 50 mm, therefore the geometric mean diameter,

$$D = \sqrt{30 \times 50} = 38.73 \text{ mm}$$

We know that standard tolerance unit,

$$i = 0.45 \sqrt[3]{D} + 0.001 D$$

$$= 0.45 \sqrt[3]{38.73} + 0.001 \times 38.73$$

$$= 0.45 \times 3.38 + 0.03873 = 1.559 73 \text{ or } 1.56 \text{ microns}$$

$$= 1.56 \times 0.001 = 0.001 56 \text{ mm} \quad \dots(\because 1 \text{ micron} = 0.001 \text{ mm})$$

From Table 3.2, we find that standard tolerance for the hole of grade 8 (IT 8)

$$= 25 i = 25 \times 0.001 56 = 0.039 \text{ mm Ans.}$$

and standard tolerance for the shaft of grade 7 (IT 7)

$$= 16 i = 16 \times 0.001 56 = 0.025 \text{ mm Ans.}$$

*Fundamental deviation*

We know that fundamental deviation (lower deviation) for hole  $H$ ,

$$EI = 0$$

From Table 3.7, we find that fundamental deviation (upper deviation) for shaft  $f$ ,

$$\begin{aligned} es &= -5.5 (D)^{0.41} \\ &= -5.5 (38.73)^{0.41} = -24.63 \text{ or } -25 \text{ microns} \\ &= -25 \times 0.001 = -0.025 \text{ mm Ans.} \end{aligned}$$

$\therefore$  Fundamental deviation (lower deviation) for shaft  $f$ ,

$$ei = es - IT = -0.025 - 0.025 = -0.050 \text{ mm Ans.}$$

The -ve sign indicates that fundamental deviation lies below the zero line.

*Limits of sizes*

We know that lower limit for hole

$$= \text{Basic size} = 40 \text{ mm Ans.}$$

Upper limit for hole = Lower limit for hole + Tolerance for hole

$$= 40 + 0.039 = 40.039 \text{ mm Ans.}$$

Upper limit for shaft = Lower limit for hole or Basic size – Fundamental deviation

$$\text{(upper deviation)} \quad \dots (\because \text{Shaft } f \text{ lies below the zero line})$$

$$= 40 - 0.025 = 39.975 \text{ mm Ans.}$$

and lower limit for shaft = Upper limit for shaft – Tolerance for shaft

$$= 39.975 - 0.025 = 39.95 \text{ mm Ans.}$$

**Problem-3:**

A journal of nominal or basic size of 75 mm runs in a bearing with close running fit. Find the limits of shaft and bearing. What is the maximum and minimum clearance?

**Solution.** Given: Nominal or basic size = 75 mm

From Table 3.5, we find that the close running fit is represented by  $H 8/g 7$ , i.e. a shaft  $g 7$  should be used with  $H 8$  hole.

Since 75 mm lies in the diameter steps of 50 to 80 mm, therefore the geometric mean diameter,

$$D = \sqrt{50 \times 80} = 63 \text{ mm}$$

We know that standard tolerance unit,

$$\begin{aligned} i &= 0.45 \sqrt[3]{D} + 0.001 D = 0.45 \sqrt[3]{63} + 0.001 \times 63 \\ &= 1.79 + 0.063 = 1.853 \text{ micron} \\ &= 1.853 \times 0.001 = 0.001 853 \text{ mm} \end{aligned}$$

$\therefore$  Standard tolerance for hole ' $H$ ' of grade 8 ( $IT 8$ )

$$= 25 i = 25 \times 0.001 853 = 0.046 \text{ mm}$$

and standard tolerance for shaft ' $g$ ' of grade 7 ( $IT 7$ )

$$= 16 i = 16 \times 0.001 853 = 0.03 \text{ mm}$$

From Table 3.7, we find that upper deviation for shaft  $g$ ,

$$\begin{aligned} es &= -2.5 (D)^{0.34} = -2.5 (63)^{0.34} = -10 \text{ micron} \\ &= -10 \times 0.001 = -0.01 \text{ mm} \end{aligned}$$

∴ Lower deviation for shaft  $g$ ,

$$ei = es - IT = -0.01 - 0.03 = -0.04 \text{ mm}$$

We know that lower limit for hole

$$= \text{Basic size} = 75 \text{ mm}$$

Upper limit for hole = Lower limit for hole + Tolerance for hole

$$= 75 + 0.046 = 75.046 \text{ mm}$$

Upper limit for shaft = Lower limit for hole – Upper deviation for shaft

... (∵ Shaft  $g$  lies below zero line)

$$= 75 - 0.01 = 74.99 \text{ mm}$$

and lower limit for shaft = Upper limit for shaft – Tolerance for shaft

$$= 74.99 - 0.03 = 74.96 \text{ mm}$$

We know that maximum clearance

$$= \text{Upper limit for hole} - \text{Lower limit for shaft}$$

$$= 75.046 - 74.96 = 0.086 \text{ mm Ans.}$$

and minimum clearance = Lower limit for hole – Upper limit for shaft

$$= 75 - 74.99 = 0.01 \text{ mm Ans.}$$

### References:

1. Machine Design - V. Bandari .
2. Machine Design – R.S. Khurmi
3. Design Data hand Book - S MD Jalaludin.



### Stress

When some external system of forces or loads acts on a body, the internal forces (equal and opposite) are set up at various sections of the body, which resist the external forces. This internal force per unit area at any section of the body is known as **unit stress** or simply a **stress**. It is denoted by a Greek letter sigma ( $\sigma$ ). Mathematically,

$$\text{Stress, } \sigma = P/A$$

Where  $P$  = Force or load acting on a body, and  
 $A$  = Cross-sectional area of the body.

In S.I. units, the stress is usually expressed in Pascal (Pa) such that  $1 \text{ Pa} = 1 \text{ N/m}^2$ . In actual practice, we use bigger units of stress *i.e.* megapascal (MPa) and gigapascal (GPa), such that

$$1 \text{ MPa} = 1 \times 10^6 \text{ N/m}^2 = 1 \text{ N/mm}^2$$

$$\text{And } 1 \text{ GPa} = 1 \times 10^9 \text{ N/m}^2 = 1 \text{ kN/mm}^2$$

### Strain

When a system of forces or loads act on a body, it undergoes some deformation. This deformation per unit length is known as **unit strain** or simply a **strain**. It is denoted by a Greek letter epsilon ( $\epsilon$ ). Mathematically,

$$\text{Strain, } \epsilon = \delta l / l \quad \text{or } \delta l = \epsilon.l$$

Where  $\delta l$  = Change in length of the body, and  
 $l$  = Original length of the body.

### Tensile Stress and Strain

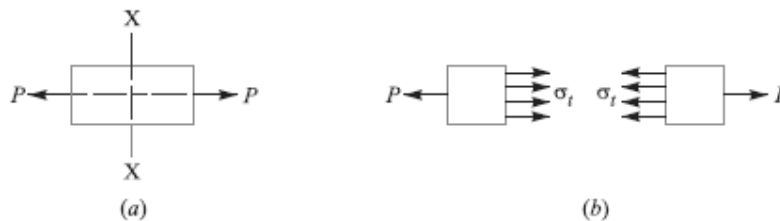

Fig. Tensile stress and strain

When a body is subjected to two equal and opposite axial pulls  $P$  (also called tensile load) as shown in Fig. (a), then the stress induced at any section of the body is known as **tensile stress**

as shown in Fig. (b). A little consideration will show that due to the tensile load, there will be a decrease in cross-sectional area and an increase in length of the body. The ratio of the increase in length to the original length is known as *tensile strain*.

Let  $P$  = Axial tensile force acting on the body,

$A$  = Cross-sectional area of the body,

$l$  = Original length, and

$\delta l$  = Increase in length.

Then Tensile stress,  $\sigma_t = P/A$

and tensile strain,  $\epsilon_t = \delta l / l$

### Young's Modulus or Modulus of Elasticity

**Hooke's law\*** states that when a material is loaded within elastic limit, the stress is directly proportional to strain, *i.e.*

$$\sigma \propto \epsilon \quad \text{or} \quad \sigma = E \cdot \epsilon$$

$$E = \frac{\sigma}{\epsilon} = \frac{P \times l}{A \times \delta l}$$

where  $E$  is a constant of proportionality known as *Young's modulus* or *modulus of elasticity*. In S.I. units, it is usually expressed in GPa *i.e.* GN/m<sup>2</sup> or kN/mm<sup>2</sup>. It may be noted that Hooke's law holds good for tension as well as compression.

The following table shows the values of modulus of elasticity or Young's modulus ( $E$ ) for the materials commonly used in engineering practice.

Values of  $E$  for the commonly used engineering materials.

Material	Modulus of elasticity ( $E$ ) in GPa <i>i.e.</i> GN/m <sup>2</sup> for kN/mm <sup>2</sup>
Steel and Nickel	200 to 220
Wrought iron	190 to 200
Cast iron	100 to 160
Copper	90 to 110
Brass	80 to 90
Aluminium	60 to 80
Timber	10

**Shear Stress and Strain**

When a body is subjected to two equal and opposite forces acting tangentially across the resisting section, as a result of which the body tends to shear off the section, then the stress induced is called *shear stress*.

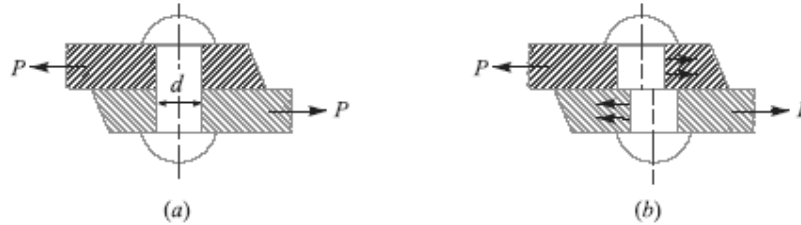

Fig. Single shearing of a riveted joint.

The corresponding strain is known as *shear strain* and it is measured by the angular deformation accompanying the shear stress. The shear stress and shear strain are denoted by the Greek letters tau ( $\tau$ ) and phi ( $\phi$ ) respectively. Mathematically,

$$\text{Shear stress, } \tau = \frac{\text{Tangential force}}{\text{Resisting area}}$$

Consider a body consisting of two plates connected by a rivet as shown in Fig. (a). In this case, the tangential force  $P$  tends to shear off the rivet at one cross-section as shown in Fig. (b). It may be noted that when the tangential force is resisted by one cross-section of the rivet (or when shearing takes place at one cross-section of the rivet), then the rivets are said to be in *single shear*. In such a case, the area resisting the shear off the rivet,

$$A = \frac{\pi}{4} \times d^2$$

And shear stress on the rivet cross-section

$$\tau = \frac{P}{A} = \frac{P}{\frac{\pi}{4} \times d^2} = \frac{4P}{\pi d^2}$$

Now let us consider two plates connected by the two cover plates as shown in Fig. (a). In this case, the tangential force  $P$  tends to shear off the rivet at two cross-sections as shown in Fig. (b). It may be noted that when the tangential force is resisted by two cross-sections of the



rivet (or when the shearing takes place at Two cross-sections of the rivet), then the rivets are said to be in *double shear*. In such a case, the area resisting the shear off the rivet,

$$A = 2 \times \frac{\pi}{4} \times d^2 \quad (\text{For double shear})$$

and shear stress on the rivet cross-section.

$$\tau = \frac{P}{A} = \frac{P}{2 \times \frac{\pi}{4} \times d^2} = \frac{2P}{\pi d^2}$$

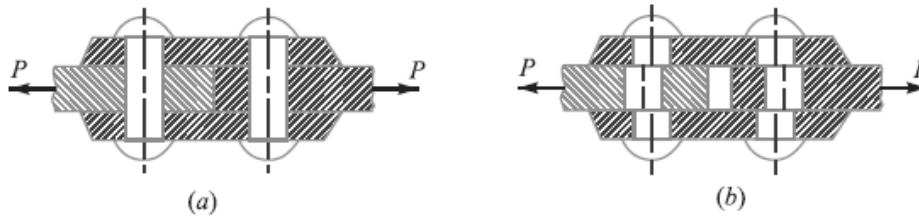

Fig. Double shearing of a riveted joint.

**Notes:**

1. All lap joints and single cover butt joints are in single shear, while the butt joints with double cover plates are in double shear.
2. In case of shear, the area involved is parallel to the external force applied.
3. When the holes are to be punched or drilled in the metal plates, then the tools used to perform the operations must overcome the ultimate shearing resistance of the material to be cut. If a hole of diameter ‘d’ is to be punched in a metal plate of thickness ‘t’, then the area to be sheared,

$$A = \pi d \times t$$

And the maximum shear resistance of the tool or the force required to punch a hole,

$$P = A \times \tau_u = \pi d \times t \times \tau_u$$

Where  $\tau_u$  = Ultimate shear strength of the material of the plate.

**Shear Modulus or Modulus of Rigidity**

It has been found experimentally that within the elastic limit, the shear stress is directly proportional to shear strain. Mathematically

$$\tau \propto \phi \quad \text{or} \quad \tau = C \cdot \phi \quad \text{or} \quad \tau / \phi = C$$

Where  $\tau$ = Shear stress,

$\phi$ = Shear strain, and

$C$  = Constant of proportionality, known as shear modulus or modulus of rigidity. It is also denoted by  $N$  or  $G$ .

The following table shows the values of modulus of rigidity ( $C$ ) for the materials in every day use:

Values of  $C$  for the commonly used materials

Material	Modulus of rigidity ( $C$ ) in GPa i.e. $\text{GN/m}^2$ or $\text{kNmm}^2$
Steel	80 to 100
Wrought iron	80 to 90
Cast iron	40 to 50
Copper	30 to 50
Brass	30 to 50
Timber	10

### Linear and Lateral Strain

Consider a circular bar of diameter  $d$  and length  $l$ , subjected to a tensile force  $P$  as shown in Fig. (a).

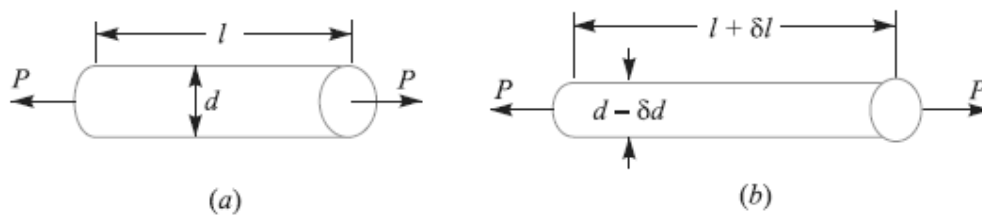

Fig. Linear and lateral strain.

A little consideration will show that due to tensile force, the length of the bar increases by an amount  $\delta l$  and the diameter decreases by an amount  $\delta d$ , as shown in Fig. (b). similarly, if the bar is subjected to a compressive force, the length of bar will decrease which will be followed by increase in diameter.

It is thus obvious, that every direct stress is accompanied by a strain in its own direction which is known as **linear strain** and an opposite kind of strain in every direction, at right angles to it, is known as **lateral strain**.

**4.18 Poisson's Ratio**

It has been found experimentally that when a body is stressed within elastic limit, the lateral strain bears a constant ratio to the linear strain, Mathematically,

$$\frac{\text{LateralStrain}}{\text{LinearStrain}} = \text{Constant}$$

This constant is known as **Poisson's ratio** and is denoted by  $1/m$  or  $\mu$ .

Following are the values of Poisson's ratio for some of the materials commonly used in engineering practice.

Values of Poisson's ratio for commonly used materials

S.No.	Material	Poisson 's ratio (1/m or $\mu$ )
1	Steel	0.25 to 0.33
2	Cast iron	0.23 to 0.27
3	Copper	0.31 to 0.34
4	Brass	0.32 to 0.42
5	Aluminium	0.32 to 0.36
6	Concrete	0.08 to 0.18
7	Rubber	0.45 to 0.50

**Volumetric Strain**

When a body is subjected to a system of forces, it undergoes some changes in its dimensions. In other words, the volume of the body is changed. The ratio of the change in volume to the original volume is known as **volumetric strain**. Mathematically, volumetric strain,

$$\epsilon_v = \delta V / V$$

Where  $\delta V$  = Change in volume, and  $V$  = Original volume

**Notes : 1.** Volumetric strain of a rectangular body subjected to an axial force is given as

$$\epsilon_v = \frac{\delta V}{V} = \epsilon \left( 1 - \frac{2}{m} \right); \text{ where } \epsilon = \text{Linear strain.}$$

**2.** Volumetric strain of a rectangular body subjected to three mutually perpendicular forces is given by

## Lecture Notes – 4

$$\epsilon_v = \epsilon_x + \epsilon_y + \epsilon_z$$

where  $\epsilon_x$ ,  $\epsilon_y$  and  $\epsilon_z$  are the strains in the directions  $x$ -axis,  $y$ -axis and  $z$ -axis respectively.

**Bulk Modulus**

When a body is subjected to three mutually perpendicular stresses, of equal intensity, then the ratio of the direct stress to the corresponding volumetric strain is known as **bulk modulus**. It is usually denoted by  $K$ . Mathematically, bulk modulus,

$$K = \frac{\text{Direct stress}}{\text{Volumetric strain}} = \frac{\sigma}{\delta V/V}$$

**Relation Between Bulk Modulus and Young's Modulus**

The bulk modulus ( $K$ ) and Young's modulus ( $E$ ) are related by the following relation,

$$K = \frac{m.E}{3(m-2)} = \frac{E}{3(1-2\mu)}$$

**Relation between Young's Modulus and Modulus of Rigidity**

The Young's modulus ( $E$ ) and modulus of rigidity ( $G$ ) are related by the following relation,

$$G = \frac{m.E}{2(m+1)} = \frac{E}{2(1+\mu)}$$

**Factor of Safety**

It is defined, in general, as the **ratio of the maximum stress to the working stress**.

Mathematically,

$$\text{Factor of safety} = \text{Maximum stress} / \text{Working or design stress}$$

In case of ductile materials *e.g.* mild steel, where the yield point is clearly defined, the factor of safety is based upon the yield point stress. In such cases,

$$\text{Factor of safety} = \text{Yield point stress} / \text{Working or design stress}$$

In case of brittle materials *e.g.* cast iron, the yield point is not well defined as for ductile materials. Therefore, the factor of safety for brittle materials is based on ultimate stress.

$$\text{Factor of safety} = \text{Ultimate stress} / \text{Working or design stress}$$

This relation may also be used for ductile materials.

The above relations for factor of safety are for static loading.

**Problem:**

A steel bar 2.4 m long and 30 mm square is elongated by a load of 500 kN. If poisson's ratio is 0.25, find the increase in volume. Take  $E = 0.2 \times 10^6 \text{ N/mm}^2$ .

**Solution.** Given :  $l = 2.4 \text{ m} = 2400 \text{ mm}$  ;  $A = 30 \times 30 = 900 \text{ mm}^2$  ;  $P = 500 \text{ kN} = 500 \times 10^3 \text{ N}$  ;  
 $l/m = 0.25$  ;  $E = 0.2 \times 10^6 \text{ N/mm}^2$

Let  $\delta V =$  Increase in volume.

We know that volume of the rod,

$$V = \text{Area} \times \text{length} = 900 \times 2400 = 2160 \times 10^3 \text{ mm}^3$$

and Young's modulus,  $E = \frac{\text{Stress}}{\text{Strain}} = \frac{P/A}{\epsilon}$

$$\therefore \epsilon = \frac{P}{A.E} = \frac{500 \times 10^3}{900 \times 0.2 \times 10^6} = 2.8 \times 10^{-3}$$

We know that volumetric strain,

$$\frac{\delta V}{V} = \epsilon \left( 1 - \frac{2}{m} \right) = 2.8 \times 10^{-3} (1 - 2 \times 0.25) = 1.4 \times 10^{-3}$$

$$\therefore \delta V = V \times 1.4 \times 10^{-3} = 2160 \times 10^3 \times 1.4 \times 10^{-3} = 3024 \text{ mm}^3 \text{ Ans.}$$

**References:**

1. Machine Design - V.Bandari .
2. Machine Design – R.S. Khurmi
3. Design Data hand Book - S MD Jalaludin.



**Stresses due to Change in Temperature—Thermal Stresses**

Whenever there is some increase or decrease in the temperature of a body, it causes the body to expand or contract. A little consideration will show that if the body is allowed to expand or contract freely, with the rise or fall of the temperature, no stresses are induced in the body. But, if the deformation of the body is prevented, some stresses are induced in the body. Such stresses are known as *thermal stresses*.

Let  $l$  = Original length of the body,  
 $t$  = Rise or fall of temperature, and  
 $\alpha$  = Coefficient of thermal expansion,  
 $\delta l$  Increase or decrease in length,

$$\delta l = l \cdot \alpha \cdot t$$

If the ends of the body are fixed to rigid supports, so that its expansion is prevented, then compressive strain induced in the body,

$$\epsilon_c = \frac{\delta l}{l} = \frac{l \cdot \alpha \cdot t}{l} = \alpha \cdot t$$

Thermal stress,

$$\sigma_{th} = \epsilon_c \cdot E = \alpha \cdot t \cdot E$$

1. When a body is composed of two or different materials having different coefficient of thermal expansions, then due to the rise in temperature, the material with higher coefficient of thermal expansion will be subjected to compressive stress whereas the material with low coefficient of expansion will be subjected to tensile stress.

2. When a thin tyre is shrunk on to a wheel of diameter  $D$ , its internal diameter  $d$  is a little less than the wheel diameter. When the tyre is heated, its circumference  $\pi d$  will increase to  $\pi D$ . In this condition, it is slipped on to the wheel. When it cools, it wants to return to its original circumference  $\pi d$ , but the wheel if it is assumed to be rigid, prevents it from doing so.

$$\text{Strain, } \epsilon = \frac{\pi D - \pi d}{\pi d} = \frac{D - d}{d}$$

This strain is known as *circumferential* or *hoop strain*.

Therefore, Circumferential or hoop stress,

$$\sigma = E \cdot \epsilon = \frac{E(D-d)}{d}$$

Problem:

A composite bar made of aluminum and steel is held between the supports as shown in Fig. The bars are stress free at a temperature of 37°C. What will be the stress in the two bars when the temperature is 20°C, if (a) the supports are unyielding; and (b) the supports yield and come nearer to each other by 0.10 mm?

It can be assumed that the change of temperature is uniform all along the length of the bar.

Take  $E_s = 210 \text{ GPa}$  ;  $E_a = 74 \text{ GPa}$  ;  $\alpha_s = 11.7 \times 10^{-6} / ^\circ\text{C}$  ; and  $\alpha_a = 23.4 \times 10^{-6} / ^\circ\text{C}$ .

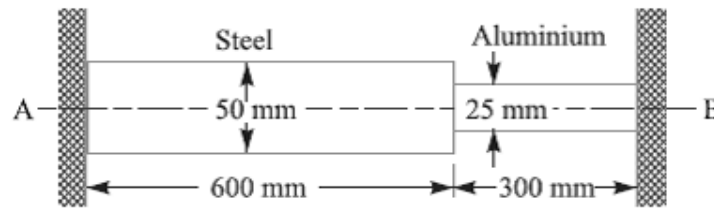

Solution. Given :  $t_1 = 37^\circ\text{C}$  ;  $t_2 = 20^\circ\text{C}$  ;  $E_s = 210 \text{ GPa} = 210 \times 10^9 \text{ N/m}^2$  ;  $E_a = 74 \text{ GPa} = 74 \times 10^9 \text{ N/m}^2$  ;  $\alpha_s = 11.7 \times 10^{-6} / ^\circ\text{C}$  ;  $\alpha_a = 23.4 \times 10^{-6} / ^\circ\text{C}$  ,  $d_s = 50 \text{ mm} = 0.05 \text{ m}$  ;  $d_a = 25 \text{ mm} = 0.025 \text{ m}$  ;  $l_s = 600 \text{ mm} = 0.6 \text{ m}$  ;  $l_a = 300 \text{ mm} = 0.3 \text{ m}$

Let us assume that the right support at B is removed and the bar is allowed to contract freely due to the fall in temperature. We know that the fall in temperature,

$$t = t_1 - t_2 = 37 - 20 = 17^\circ\text{C}$$

∴ Contraction in steel bar

$$= \alpha_s \cdot l_s \cdot t = 11.7 \times 10^{-6} \times 600 \times 17 = 0.12 \text{ mm}$$

and contraction in aluminium bar

$$= \alpha_a \cdot l_a \cdot t = 23.4 \times 10^{-6} \times 300 \times 17 = 0.12 \text{ mm}$$

$$\text{Total contraction} = 0.12 + 0.12 = 0.24 \text{ mm} = 0.24 \times 10^{-3} \text{ m}$$

It may be noted that even after this contraction (*i.e.* 0.24 mm) in length, the bar is still stress free as the right hand end was assumed free.

Let an axial force  $P$  is applied to the right end till this end is brought in contact with the right hand support at B, as shown in Fig.

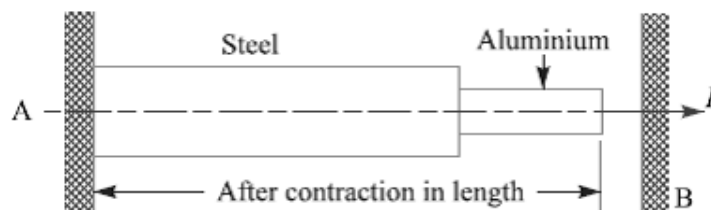

We know that cross-sectional area of the steel bar,

$$A_s = \frac{\pi}{4} (d_s)^2 = \frac{\pi}{4} (0.05)^2 = 1.964 \times 10^{-3} \text{ m}^2$$

and cross-sectional area of the aluminium bar,

$$A_a = \frac{\pi}{4} (d_a)^2 = \frac{\pi}{4} (0.025)^2 = 0.491 \times 10^{-3} \text{ m}^2$$

We know that elongation of the steel bar,

$$\begin{aligned} \delta l_s &= \frac{P \times l_s}{A_s \times E_s} = \frac{P \times 0.6}{1.964 \times 10^{-3} \times 210 \times 10^9} = \frac{0.6P}{412.44 \times 10^6} \text{ m} \\ &= 1.455 \times 10^{-9} P \text{ m} \end{aligned}$$

and elongation of the aluminium bar,

$$\begin{aligned} \delta l_a &= \frac{P \times l_a}{A_a \times E_a} = \frac{P \times 0.3}{0.491 \times 10^{-3} \times 74 \times 10^9} = \frac{0.3P}{36.334 \times 10^6} \text{ m} \\ &= 8.257 \times 10^{-9} P \text{ m} \end{aligned}$$

∴ Total elongation,

$$\begin{aligned} \delta l &= \delta l_s + \delta l_a \\ &= 1.455 \times 10^{-9} P + 8.257 \times 10^{-9} P = 9.712 \times 10^{-9} P \text{ m} \end{aligned}$$

Let

$\sigma_s$  = Stress in the steel bar, and

$\sigma_a$  = Stress in the aluminium bar.

(a) When the supports are unyielding

When the supports are unyielding, the total contraction is equated to the total elongation, i.e.

$$0.24 \times 10^{-3} = 9.712 \times 10^{-9} P \quad \text{or} \quad P = 24\,712 \text{ N}$$

∴ Stress in the steel bar,

$$\begin{aligned} \sigma_s &= P/A_s = 24\,712 / (1.964 \times 10^{-3}) = 12\,582 \times 10^3 \text{ N/m}^2 \\ &= 12.582 \text{ MPa} \quad \text{Ans.} \end{aligned}$$

and stress in the aluminium bar,

$$\begin{aligned} \sigma_a &= P/A_a = 24\,712 / (0.491 \times 10^{-3}) = 50\,328 \times 10^3 \text{ N/m}^2 \\ &= 50.328 \text{ MPa} \quad \text{Ans.} \end{aligned}$$

(b) When the supports yield by 0.1 mm

When the supports yield and come nearer to each other by 0.10 mm, the net contraction in length

$$= 0.24 - 0.1 = 0.14 \text{ mm} = 0.14 \times 10^{-3} \text{ m}$$

Problem:

A copper bar 50 mm in diameter is placed within a steel tube 75 mm external diameter and 50 mm internal diameter of exactly the same length. The two pieces are rigidly fixed together by two pins 18 mm in diameter, one at each end passing through the bar and tube. Calculate the stress induced in the copper bar, steel tube and pins if the temperature of the combination is



raised by  $50^{\circ}\text{C}$ . Take  $E_s = 210 \text{ GN/m}^2$ ;  $E_c = 105 \text{ GN/m}^2$ ;  $\alpha_s = 11.5 \times 10^{-6}/^{\circ}\text{C}$  and  $\alpha_c = 17 \times 10^{-6}/^{\circ}\text{C}$ .

**Solution.** Given:  $d_c = 50 \text{ mm}$ ;  $d_{se} = 75 \text{ mm}$ ;  $d_{si} = 50 \text{ mm}$ ;  $d_p = 18 \text{ mm} = 0.018 \text{ m}$ ;  $t = 50^{\circ}\text{C}$ ;  $E_s = 210 \text{ GN/m}^2 = 210 \times 10^9 \text{ N/m}^2$ ;  $E_c = 105 \text{ GN/m}^2 = 105 \times 10^9 \text{ N/m}^2$ ;  $\alpha_s = 11.5 \times 10^{-6}/^{\circ}\text{C}$ ;  $\alpha_c = 17 \times 10^{-6}/^{\circ}\text{C}$

The copper bar in a steel tube is shown in Fig. 4.18.

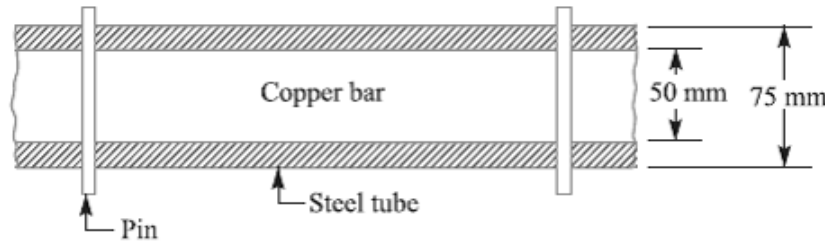

We know that cross-sectional area of the copper bar,

$$A_c = \frac{\pi}{4} (d_c)^2 = \frac{\pi}{4} (50)^2 = 1964 \text{ mm}^2 = 1964 \times 10^{-6} \text{ m}^2$$

and cross-sectional area of the steel tube,

$$A_s = \frac{\pi}{4} [(d_{se})^2 - (d_{si})^2] = \frac{\pi}{4} [(75)^2 - (50)^2] = 2455 \text{ mm}^2 \\ = 2455 \times 10^{-6} \text{ m}^2$$

Let  $l =$  Length of the copper bar and steel tube.

We know that free expansion of copper bar

$$= \alpha_c \cdot l \cdot t = 17 \times 10^{-6} \times l \times 50 = 850 \times 10^{-6} l$$

and free expansion of steel tube

$$= \alpha_s \cdot l \cdot t = 11.5 \times 10^{-6} \times l \times 50 = 575 \times 10^{-6} l$$

$\therefore$  Difference in free expansion

$$= 850 \times 10^{-6} l - 575 \times 10^{-6} l = 275 \times 10^{-6} l \quad \dots(i)$$

Since the free expansion of the copper bar is more than the free expansion of the steel tube, therefore the copper bar is subjected to a compressive stress, while the steel tube is subjected to a tensile stress. Let a compressive force  $P$  newton on the copper bar opposes the extra expansion of the copper bar and an equal tensile force  $P$  on the steel tube pulls the steel tube so that the net effect of reduction in length of copper bar and the increase in length of steel tube equalizes the difference in free expansion of the two.

Therefore, Reduction in length of copper bar due to force  $P$

$$= \frac{P \cdot l}{A_c \cdot E_c}$$

$$= \frac{P.l}{1964 \times 10^{-6} \times 105 \times 10^9} = \frac{P.l}{206.22 \times 10^6} \text{ m}$$

and increase in length of steel bar due to force  $P$

$$= \frac{P.l}{A_s \cdot E_s} = \frac{P.l}{2455 \times 10^{-6} \times 210 \times 10^9} = \frac{P.l}{515.55 \times 10^6} \text{ m}$$

$$\therefore \text{Net effect in length} = \frac{P.l}{206.22 \times 10^6} + \frac{P.l}{515.55 \times 10^6}$$

$$= 4.85 \times 10^{-9} P.l + 1.94 \times 10^{-9} P.l = 6.79 \times 10^{-9} P.l$$

Equating this net effect in length to the difference in free expansion, we have

$$6.79 \times 10^{-9} P.l = 275 \times 10^{-6} l \quad \text{or} \quad P = 40\,500 \text{ N}$$

*Stress induced in the copper bar, steel tube and pins*

We know that stress induced in the copper bar,

$$\sigma_c = P / A_c = 40\,500 / (1964 \times 10^{-6}) = 20.62 \times 10^6 \text{ N/m}^2 = 20.62 \text{ MPa Ans.}$$

Stress induced in the steel tube,

$$\sigma_s = P / A_s = 40\,500 / (2455 \times 10^{-6}) = 16.5 \times 10^6 \text{ N/m}^2 = 16.5 \text{ MPa Ans.}$$

and shear stress induced in the pins,

$$\tau_p = \frac{P}{2 A_p} = \frac{40\,500}{2 \times \frac{\pi}{4} (0.018)^2} = 79.57 \times 10^6 \text{ N/m}^2 = 79.57 \text{ MPa Ans.}$$

...( $\because$  The pin is in double shear )

### References:

1. Machine Design - V.Bandari .
2. Machine Design – R.S. Khurmi
3. Design Data hand Book - S MD Jalaludin.

**Impact Stress**

Sometimes, machine members are subjected to the load with impact. The stress produced in the member due to the falling load is known as **impact stress**. Consider a bar carrying a load  $W$  at a height  $h$  and falling on the collar provided at the lower end, as shown in Fig.

Let  $A$  = Cross-sectional area of the bar,

$E$  = Young's modulus of the material of the bar,

$l$  = Length of the bar,

$\delta l$  = Deformation of the bar,

$P$  = Force at which the deflection  $\delta l$  is produced,

$\sigma_i$  = Stress induced in the bar due to the application of impact load, and

$h$  = Height through which the load falls.

We know that energy gained by the system in the form of strain energy

$$= \frac{1}{2} \times P \times \delta l$$

And potential energy lost by the weight

$$= W(h + \delta l)$$

Since the energy gained by the system is equal to the potential energy lost by the weight, therefore

$$\begin{aligned} \frac{1}{2} \times P \times \delta l &= W(h + \delta l) \\ \frac{1}{2} \sigma_i \times A \times \frac{\sigma_i \times l}{E} &= W \left( h + \frac{\sigma_i \times l}{E} \right) \quad \dots \left[ \because P = \sigma_i \times A, \text{ and } \delta l = \frac{\sigma_i \times l}{E} \right] \\ \therefore \frac{Al}{2E} (\sigma_i)^2 - \frac{Wl}{E} (\sigma_i) - Wh &= 0 \end{aligned}$$

From this quadratic equation, we find that

$$\sigma_i = \frac{W}{A} \left( 1 + \sqrt{1 + \frac{2hAE}{Wl}} \right) \quad \dots \text{ [Taking +ve sign for maximum value]}$$

When  $h = 0$ , then  $\sigma_i = 2W/A$ . This means that the stress in the bar when the load is applied suddenly is double of the stress induced due to gradually applied load.

**Problem:**

An unknown weight falls through 10 mm on a collar rigidly attached to the lower end of a vertical bar 3 m long and 600 mm<sup>2</sup> in section. If the maximum instantaneous extension is known to be 2 mm, what is the corresponding stress and the value of unknown weight? Take  $E = 200 \text{ kN/mm}^2$ .

**Solution.** Given :  $h = 10 \text{ mm}$  ;  $l = 3 \text{ m} = 3000 \text{ mm}$  ;  $A = 600 \text{ mm}^2$  ;  $\delta l = 2 \text{ mm}$  ;  
 $E = 200 \text{ kN/mm}^2 = 200 \times 10^3 \text{ N/mm}^2$

*Stress in the bar*

Let  $\sigma =$  Stress in the bar.

We know that Young's modulus,

$$E = \frac{\text{Stress}}{\text{Strain}} = \frac{\sigma}{\epsilon} = \frac{\sigma \cdot l}{\delta l}$$

$$\therefore \sigma = \frac{E \cdot \delta l}{l} = \frac{200 \times 10^3 \times 2}{3000} = \frac{400}{3} = 133.3 \text{ N/mm}^2 \text{ Ans.}$$

*Value of the unknown weight*

Let  $W =$  Value of the unknown weight.

We know that 
$$\sigma = \frac{W}{A} \left[ 1 + \sqrt{1 + \frac{2hAE}{Wl}} \right]$$

$$\frac{400}{3} = \frac{W}{600} \left[ 1 + \sqrt{1 + \frac{2 \times 10 \times 600 \times 200 \times 10^3}{W \times 3000}} \right]$$

$$\frac{400 \times 600}{3W} = 1 + \sqrt{1 + \frac{800\,000}{W}}$$

$$\frac{80\,000}{W} - 1 = \sqrt{1 + \frac{800\,000}{W}}$$

Squaring both sides,

$$\frac{6400 \times 10^6}{W^2} + 1 - \frac{160\,000}{W} = 1 + \frac{800\,000}{W}$$

$$\frac{6400 \times 10^2}{W} - 16 = 80 \quad \text{or} \quad \frac{6400 \times 10^2}{W} = 96$$

$$\therefore W = 6400 \times 10^2 / 96 = 6666.7 \text{ N Ans.}$$

### Resilience

When a body is loaded within elastic limit, it changes its dimensions and on the removal of the load, it regains its original dimensions. So long as it remains loaded, it has stored energy in itself. On removing the load, the energy stored is given off as in the case of a spring. This energy, which is absorbed in a body when strained within elastic limit, is known as **strain energy**. The strain energy is always capable of doing some work.

The strain energy stored in a body due to external loading, within elastic limit, is known as **resilience** and the maximum energy which can be stored in a body up to the elastic limit is called **proof resilience**. The proof resilience per unit volume of a material is known as

**modulus of resilience.** It is an important property of a material and gives capacity of the material to bear impact or shocks. Mathematically, strain energy stored in a body due to tensile or compressive load or resilience,

$$U = \frac{\sigma^2 \times V}{2E}$$

And Modulus of resilience

$$= \frac{\sigma^2}{2E}$$

Where  $\sigma$  = Tensile or compressive stress,

$V$  = Volume of the body, and

$E$  = Young's modulus of the material of the body.

When a body is subjected to a shear load, then modulus of resilience (shear)

$$= \frac{\tau^2}{2C}$$

Where  $\tau$  = Shear stress, and

$C$  = Modulus of rigidity.

When the body is subjected to torsion, then modulus of resilience

$$= \frac{\tau^2}{4C}$$

Problem:

A wrought iron bar 50 mm in diameter and 2.5 m long transmits shock energy of 100 N-m.

Find the maximum instantaneous stress and the elongation. Take  $E = 200 \text{ GN/m}^2$ .

**Solution.** Given :  $d = 50 \text{ mm}$  ;  $l = 2.5 \text{ m} = 2500 \text{ mm}$  ;  $U = 100 \text{ N-m} = 100 \times 10^3 \text{ N-mm}$  ;  
 $E = 200 \text{ GN/m}^2 = 200 \times 10^3 \text{ N/mm}^2$

**Maximum instantaneous stress**

Let  $\sigma$  = Maximum instantaneous stress.

We know that volume of the bar,

$$V = \frac{\pi}{4} \times d^2 \times l = \frac{\pi}{4} (50)^2 \times 2500 = 4.9 \times 10^6 \text{ mm}^3$$

We also know that shock or strain energy stored in the body ( $U$ ),

$$100 \times 10^3 = \frac{\sigma^2 \times V}{2E} = \frac{\sigma^2 \times 4.9 \times 10^6}{2 \times 200 \times 10^3} = 12.25 \sigma^2$$

$$\therefore \sigma^2 = 100 \times 10^3 / 12.25 = 8163 \text{ or } \sigma = 90.3 \text{ N/mm}^2 \text{ Ans.}$$

*Elongation produced*

Let  $\delta l$  = Elongation produced.

We know that Young's modulus,

$$E = \frac{\text{Stress}}{\text{Strain}} = \frac{\sigma}{\epsilon} = \frac{\sigma}{\delta l / l}$$

$$\therefore \delta l = \frac{\sigma \times l}{E} = \frac{90.3 \times 2500}{200 \times 10^3} = 1.13 \text{ mm Ans.}$$

**References:**

1. Machine Design - V.Bandari .
2. Machine Design – R.S. Khurmi
3. Design Data hand Book - S MD Jalaludin.



**Torsional Shear Stress**

When a machine member is subjected to the action of two equal and opposite couples acting in parallel planes (or torque or twisting moment), then the machine member is said to be subjected to **torsion**. The stress set up by torsion is known as **torsional shear stress**. It is zero at the centroidal axis and maximum at the outer surface. Consider a shaft fixed at one end and subjected to a torque ( $T$ ) at the other end as shown in Fig. As a result of this torque, every cross-section of the shaft is subjected to torsional shear stress. We have discussed above that the torsional shear stress is zero at the centroidal axis and maximum at the outer surface. The maximum torsional shear stress at the outer surface of the shaft may be obtained from the following equation:

$$\frac{\tau}{r} = \frac{T}{J} = \frac{C \cdot \theta}{l} \text{ ----- (i)}$$

Where  $\tau$  = Torsional shear stress induced at the outer surface of the shaft or maximum shear stress,

$r$  = Radius of the shaft,

$T$  = Torque or twisting moment,

$J$  = Second moment of area of the section about its polar axis or polar moment of inertia,

$C$  = Modulus of rigidity for the shaft material,

$l$  = Length of the shaft, and

$\theta$  = Angle of twist in radians on a length  $l$ .

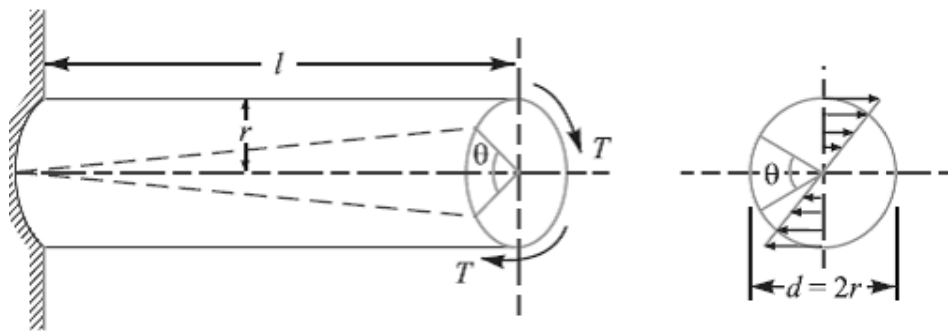

The above equation is known as **torsion equation**. It is based on the following assumptions:

1. The material of the shaft is uniform throughout.
2. The twist along the length of the shaft is uniform.
3. The normal cross-sections of the shaft, which were plane and circular before twist, remain plane and circular after twist.

4. All diameters of the normal cross-section which were straight before twist, remain straight with their magnitude unchanged, after twist.

5. The maximum shear stress induced in the shaft due to the twisting moment does not exceed its elastic limit value.

**Note: 1.** Since the torsional shear stress on any cross-section normal to the axis is directly proportional to the distance from the centre of the axis, therefore the torsional shear stress at a distance  $x$  from the centre of the shaft is given by

$$\frac{\tau_x}{x} = \frac{\tau}{r}$$

2. From equation (i), we know that

$$\frac{T}{J} = \frac{\tau}{r} \quad \text{or} \quad T = \tau \times \frac{J}{r}$$

For a solid shaft of diameter ( $d$ ), the polar moment of inertia,

$$J = I_{XX} + I_{YY} = \frac{\pi}{64} \times d^4 + \frac{\pi}{64} \times d^4 = \frac{\pi}{32} \times d^4$$

Therefore,

$$T = \tau \times \frac{\pi}{32} \times d^4 \times \frac{2}{d} = \frac{\pi}{16} \times \tau \times d^3$$

In case of a hollow shaft with external diameter ( $d_o$ ) and internal diameter ( $d_i$ ), the polar moment of inertia,

$$J = \frac{\pi}{32} [(d_o)^4 - (d_i)^4] \text{ and } r = \frac{d_o}{2}$$

$$T = \tau \times \frac{\pi}{32} [(d_o)^4 - (d_i)^4] \times \frac{2}{d_o} = \frac{\pi}{16} \times \tau \left[ \frac{(d_o)^4 - (d_i)^4}{d_o} \right]$$

$$= \frac{\pi}{16} \times \tau (d_o)^3 (1 - k^4) \quad \dots \left( \text{Substituting } k = \frac{d_i}{d_o} \right)$$

3. The expression ( $C \times J$ ) is called **torsional rigidity** of the shaft.

4. The strength of the shaft means the maximum torque transmitted by it. Therefore, in order to design a shaft for strength, the above equations are used. The power transmitted by the shaft (in watts) is given by

$$P = \frac{2 \pi N \cdot T}{60} = T \cdot \omega \quad \dots \left( \tau \cdot \omega = \frac{2 \pi N}{60} \right)$$



Where  $T$  = Torque transmitted in N-m, and

$\omega$  = Angular speed in rad/s.

Problem:

A shaft is transmitting 100 kW at 160 r.p.m. Find a suitable diameter for the shaft, if the maximum torque transmitted exceeds the mean by 25%. Take maximum allowable shear stress as 70 MPa.

**Solution.** Given :  $P = 100 \text{ kW} = 100 \times 10^3 \text{ W}$  ;  $N = 160 \text{ r.p.m}$  ;  $T_{max} = 1.25 T_{mean}$  ;  $\tau = 70 \text{ MPa} = 70 \text{ N/mm}^2$

Let  $T_{mean}$  = Mean torque transmitted by the shaft in N-m, and  
 $d$  = Diameter of the shaft in mm.

We know that the power transmitted ( $P$ ),

$$100 \times 10^3 = \frac{2 \pi N \cdot T_{mean}}{60} = \frac{2\pi \times 160 \times T_{mean}}{60} = 16.76 T_{mean}$$

$$\therefore T_{mean} = 100 \times 10^3 / 16.76 = 5966.6 \text{ N-m}$$

and maximum torque transmitted,

$$T_{max} = 1.25 \times 5966.6 = 7458 \text{ N-m} = 7458 \times 10^3 \text{ N-mm}$$

We know that maximum torque ( $T_{max}$ ),

$$7458 \times 10^3 = \frac{\pi}{16} \times \tau \times d^3 = \frac{\pi}{16} \times 70 \times d^3 = 13.75 d^3$$

$$\therefore d^3 = 7458 \times 10^3 / 13.75 = 542.4 \times 10^3 \text{ or } d = 81.5 \text{ mm Ans.}$$

### Bending Stress

In engineering practice, the machine parts of structural members may be subjected to static or dynamic loads which cause bending stress in the sections besides other types of stresses such as tensile, compressive and shearing stresses. Consider a straight beam subjected to a bending moment  $M$  as shown in Fig.

The following assumptions are usually made while deriving the bending formula.

1. The material of the beam is perfectly homogeneous (*i.e.* of the same material throughout) and isotropic (*i.e.* of equal elastic properties in all directions).
2. The material of the beam obeys Hooke's law.
3. The transverse sections (*i.e.*  $BC$  or  $GH$ ) which were plane before bending remain plane after bending also.
4. Each layer of the beam is free to expand or contract, independently, of the layer, above or below it.
5. The Young's modulus ( $E$ ) is the same in tension and compression.
6. The loads are applied in the plane of bending.

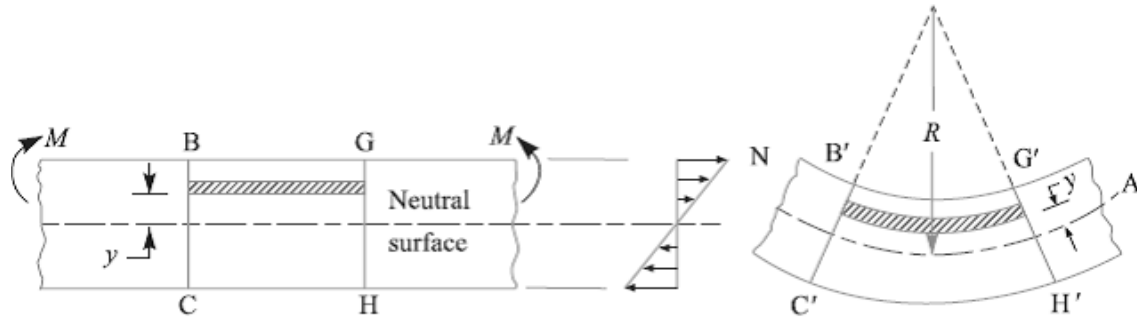

A little consideration will show that when a beam is subjected to the bending moment, the fibres on the upper side of the beam will be shortened due to compression and those on the lower side will be elongated due to tension. It may be seen that somewhere between the top and bottom fibres there is a surface at which the fibres are neither shortened nor lengthened. Such a surface is called **neutral surface**. The intersection of the neutral surface with any normal cross-section of the beam is known as **neutral axis**. The stress distribution of a beam is shown in Fig. The bending equation is given by

$$\frac{M}{I} = \frac{\sigma}{y} = \frac{E}{R}$$

Where  $M$  = Bending moment acting at the given section,

$\sigma$  = Bending stress,

$I$  = Moment of inertia of the cross-section about the neutral axis,

$y$  = Distance from the neutral axis to the extreme fibre,

$E$  = Young's modulus of the material of the beam, and

$R$  = Radius of curvature of the beam.

From the above equation, the bending stress is given by

$$\sigma = y \times \frac{E}{R}$$

Since  $E$  and  $R$  are constant, therefore within elastic limit, the stress at any point is directly proportional to  $y$ , *i.e.* the distance of the point from the neutral axis.

Also from the above equation, the bending stress,

$$\sigma = \frac{M}{I} \times y = \frac{M}{I/y} = \frac{M}{Z}$$

The ratio  $I/y$  is known as **section modulus** and is denoted by  $Z$ .

**Notes:** 1. the neutral axis of a section always passes through its centroid.

2. In case of symmetrical sections such as circular, square or rectangular, the neutral axis passes through its geometrical centre and the distance of extreme fibre from the neutral axis

is  $y = d / 2$ , where  $d$  is the diameter in case of circular section or depth in case of square or rectangular section.

3. In case of unsymmetrical sections such as L-section or T-section, the neutral axis does not pass through its geometrical centre. In such cases, first of all the centroid of the section is calculated and then the distance of the extreme fibres for both lower and upper side of the section is obtained. Out of these two values, the bigger value is used in bending equation.

**Problem:**

A beam of uniform rectangular cross-section is fixed at one end and carries an electric motor weighing 400 N at a distance of 300 mm from the fixed end. The maximum bending stress in the beam is 40 MPa. Find the width and depth of the beam, if depth is twice that of width.

**Solution.** Given:  $W = 400 \text{ N}$  ;  $L = 300 \text{ mm}$  ;  
 $\sigma_b = 40 \text{ MPa} = 40 \text{ N/mm}^2$  ;  $h = 2b$

The beam is shown in Fig. 5.7.

Let  $b =$  Width of the beam in mm, and  
 $h =$  Depth of the beam in mm.

$\therefore$  Section modulus,

$$Z = \frac{b \cdot h^2}{6} = \frac{b (2b)^2}{6} = \frac{2 b^3}{3} \text{ mm}^3$$

Maximum bending moment (at the fixed end),

$$M = W.L = 400 \times 300 = 120 \times 10^3 \text{ N-mm}$$

We know that bending stress ( $\sigma_b$ ),

$$40 = \frac{M}{Z} = \frac{120 \times 10^3 \times 3}{2 b^3} = \frac{180 \times 10^3}{b^3}$$

$$\therefore b^3 = 180 \times 10^3 / 40 = 4.5 \times 10^3 \text{ or } b = 16.5 \text{ mm Ans.}$$

and

$$h = 2b = 2 \times 16.5 = 33 \text{ mm Ans.}$$

**Problem:**

A cast iron pulley transmits 10 kW at 400 r.p.m. The diameter of the pulley is 1.2 metre and it has four straight arms of elliptical cross-section, in which the major axis is twice the minor axis. Determine the dimensions of the arm if the allowable bending stress is 15 MPa.

**Solution.** Given :  $P = 10 \text{ kW} = 10 \times 10^3 \text{ W}$  ;  $N = 400 \text{ r.p.m}$  ;  $D = 1.2 \text{ m} = 1200 \text{ mm}$  or  $R = 600 \text{ mm}$  ;  $\sigma_b = 15 \text{ MPa} = 15 \text{ N/mm}^2$

Let  $T =$  Torque transmitted by the pulley.

We know that the power transmitted by the pulley ( $P$ ),

$$10 \times 10^3 = \frac{2 \pi N \cdot T}{60} = \frac{2 \pi \times 400 \times T}{60} = 42 T$$

$$\therefore T = 10 \times 10^3 / 42 = 238 \text{ N-m} = 238 \times 10^3 \text{ N-mm}$$

Since the torque transmitted is the product of the tangential load and the radius of the pulley, therefore tangential load acting on the pulley

$$= \frac{T}{R} = \frac{238 \times 10^3}{600} = 396.7 \text{ N}$$

Since the pulley has four arms, therefore tangential load on each arm,

$$W = 396.7/4 = 99.2 \text{ N}$$

and maximum bending moment on the arm,

$$M = W \times R = 99.2 \times 600 = 59\,520 \text{ N-mm}$$

Let  $2b$  = Minor axis in mm, and

$$2a = \text{Major axis in mm} = 2 \times 2b = 4b$$

...(Given)

$\therefore$  Section modulus for an elliptical cross-section,

$$Z = \frac{\pi}{4} \times a^2 b = \frac{\pi}{4} (2b)^2 \times b = \pi b^3 \text{ mm}^3$$

We know that bending stress ( $\sigma_b$ ),

$$15 = \frac{M}{Z} = \frac{59\,520}{\pi b^3} = \frac{18\,943}{b^3}$$

or

$$b^3 = 18\,943/15 = 1263 \text{ or } b = 10.8 \text{ mm}$$

$$\therefore \text{Minor axis, } 2b = 2 \times 10.8 = 21.6 \text{ mm Ans.}$$

and

$$\text{major axis, } 2a = 2 \times 2b = 4 \times 10.8 = 43.2 \text{ mm Ans.}$$

### References:

1. Machine Design - V.Bandari .
2. Machine Design – R.S. Khurmi
3. Design Data hand Book - S MD Jalaludin.

**Principal Stresses and Principal Planes**

In the previous chapter, we have discussed about the direct tensile and compressive stress as well as simple shear. Also we have always referred the stress in a plane which is at right angles to the line of action of the force. But it has been observed that at any point in a strained material, there are three planes, mutually perpendicular to each other which carry direct stresses only and no shear stress. It may be noted that out of these three direct stresses, one will be maximum and the other will be minimum. These perpendicular planes which have no shear stress are known as *principal planes* and the direct stresses along these planes are known as *principal stresses*. The planes on which the maximum shear stress act are known as planes of maximum shear.

**Determination of Principal Stresses for a Member Subjected to Bi-axial Stress**

When a member is subjected to bi-axial stress (*i.e.* direct stress in two mutually perpendicular planes accompanied by a simple shear stress), then the normal and shear stresses are obtained as discussed below:

Consider a rectangular body  $ABCD$  of uniform cross-sectional area and unit thickness subjected to normal stresses  $\sigma_1$  and  $\sigma_2$  as shown in Fig. (a). In addition to these normal stresses, a shear stress  $\tau$  also acts. It has been shown in books on '*Strength of Materials*' that the normal stress across any oblique section such as  $EF$  inclined at an angle  $\theta$  with the direction of  $\sigma_2$ , as shown in Fig. (a), is given by

$$\sigma_t = \frac{\sigma_1 + \sigma_2}{2} + \frac{\sigma_1 - \sigma_2}{2} \cos 2\theta + \tau \sin 2\theta \quad \dots(i)$$

And tangential stress (*i.e.* shear stress) across the section  $EF$ ,

$$\tau_1 = \frac{1}{2} (\sigma_1 - \sigma_2) \sin 2\theta - \tau \cos 2\theta \quad \dots(ii)$$

Since the planes of maximum and minimum normal stress (*i.e.* principal planes) have no shear stress, therefore the inclination of principal planes is obtained by equating  $\tau_1 = 0$  in the above equation (ii), *i.e.*

$$\frac{1}{2} (\sigma_1 - \sigma_2) \sin 2\theta - \tau \cos 2\theta = 0$$

$$\tan 2\theta = \frac{2\tau}{\sigma_1 - \sigma_2} \quad \dots(iii)$$

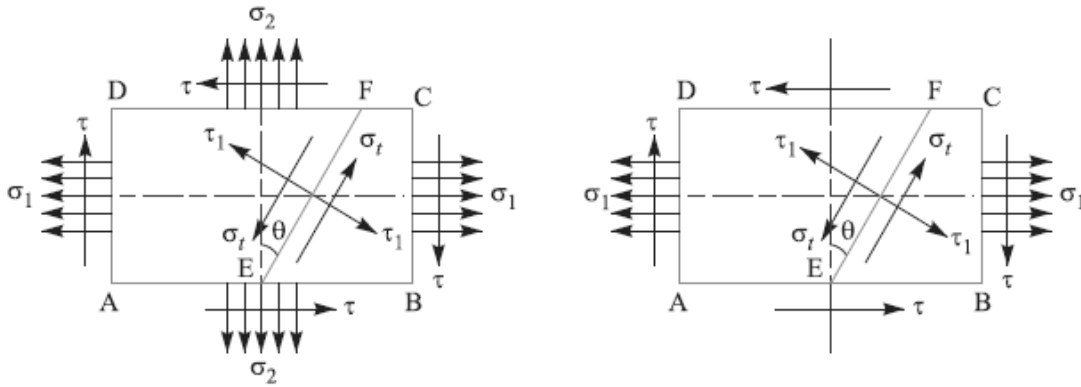

(a) Direct stress in two mutually perpendicular planes accompanied by a simple shear stress.

(b) Direct stress in one plane accompanied by a simple shear stress.

Fig. Principal stresses for a member subjected to bi-axial stress

We know that there are two principal planes at right angles to each other. Let  $\theta_1$  and  $\theta_2$  be the inclinations of these planes with the normal cross-section. From the following Fig., we find that

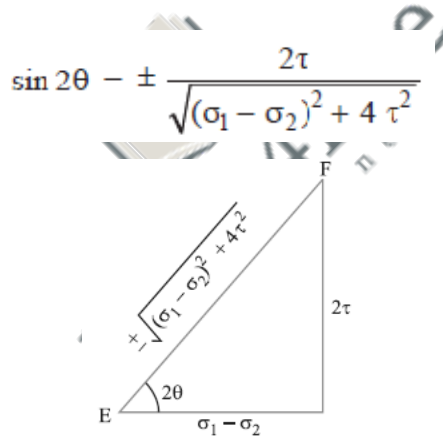

$$\therefore \sin 2\theta_1 = + \frac{2\tau}{\sqrt{(\sigma_1 - \sigma_2)^2 + 4\tau^2}}$$

and 
$$\sin 2\theta_2 = - \frac{2\tau}{\sqrt{(\sigma_1 - \sigma_2)^2 + 4\tau^2}}$$

Also 
$$\cos 2\theta = \pm \frac{\sigma_1 - \sigma_2}{\sqrt{(\sigma_1 - \sigma_2)^2 + 4\tau^2}}$$

$$\therefore \cos 2\theta_1 = + \frac{\sigma_1 - \sigma_2}{\sqrt{(\sigma_1 - \sigma_2)^2 + 4\tau^2}}$$

and 
$$\cos 2\theta_2 = - \frac{\sigma_1 - \sigma_2}{\sqrt{(\sigma_1 - \sigma_2)^2 + 4\tau^2}}$$

The maximum and minimum principal stresses may now be obtained by substituting the values of  $\sin 2\theta$  and  $\cos 2\theta$  in equation (i).

So, Maximum principal (or normal) stress,

$$\sigma_{r1} = \frac{\sigma_1 + \sigma_2}{2} + \frac{1}{2} \sqrt{(\sigma_1 - \sigma_2)^2 + 4 \tau^2} \quad \dots(iv)$$

And minimum principal (or normal) stress,

$$\sigma_{r2} = \frac{\sigma_1 + \sigma_2}{2} - \frac{1}{2} \sqrt{(\sigma_1 - \sigma_2)^2 + 4 \tau^2} \quad \dots(v)$$

The planes of maximum shear stress are at right angles to each other and are inclined at  $45^\circ$  to the principal planes. The maximum shear stress is given by **one-half the algebraic difference between the principal stresses, i.e.**

$$\tau_{max} = \frac{\sigma_1 - \sigma_2}{2} = \frac{1}{2} \sqrt{(\sigma_1 - \sigma_2)^2 + 4 \tau^2} \quad \dots(vi)$$

Notes: 1. when a member is subjected to direct stress in one plane accompanied by a simple shear stress, then the principal stresses are obtained by substituting  $\sigma_2 = 0$  in equation (iv), (v) and (vi).

$$\sigma_{r1} = \frac{\sigma_1}{2} + \frac{1}{2} \left[ \sqrt{(\sigma_1)^2 + 4 \tau^2} \right]$$

$$\sigma_{r2} = \frac{\sigma_1}{2} - \frac{1}{2} \left[ \sqrt{(\sigma_1)^2 + 4 \tau^2} \right]$$

$$\tau_{max} = \frac{1}{2} \left[ \sqrt{(\sigma_1)^2 + 4 \tau^2} \right]$$

2. In the above expression of  $\sigma_{r2}$ , the value of  $\frac{1}{2} \left[ \sqrt{(\sigma_1)^2 + 4 \tau^2} \right]$  is more than  $\sigma_1/2$ . Therefore the nature of  $\sigma_{r2}$  will be opposite to that of  $\sigma_{r1}$ , i.e. if  $\sigma_{r1}$  is tensile then  $\sigma_{r2}$  will be compressive and vice-versa.

**Application of Principal Stresses in Designing Machine Members**

There are many cases in practice, in which machine members are subjected to combined stresses due to simultaneous action of either tensile or compressive stresses combined with shear stresses. In many shafts such as propeller shafts, C-frames etc., there are direct tensile or compressive stresses due to the external force and shear stress due to torsion, which acts

normal to direct tensile or compressive stresses. The shafts like crank shafts, are subjected simultaneously to torsion and bending. In such cases, the maximum principal stresses, due to the combination of tensile or compressive stresses with shear stresses may be obtained. The results obtained in the previous article may be written as follows:

1. Maximum tensile stress,

$$\sigma_{t(max)} = \frac{\sigma_t}{2} + \frac{1}{2} \left[ \sqrt{(\sigma_t)^2 + 4 \tau^2} \right]$$

2. Maximum compressive stress,

$$\sigma_{c(max)} = \frac{\sigma_c}{2} + \frac{1}{2} \left[ \sqrt{(\sigma_c)^2 + 4 \tau^2} \right]$$

3. Maximum shear stress,

$$\tau_{max} = \frac{1}{2} \left[ \sqrt{(\sigma_t)^2 + 4 \tau^2} \right]$$

Where  $\sigma_t$  = Tensile stress due to direct load and bending,

$\sigma_c$  = Compressive stress, and

$\tau$  = Shear stress due to torsion.

**Notes:** 1. When  $\tau = 0$  as in the case of thin cylindrical shell subjected in internal fluid pressure, then  $\sigma_{tmax} = \sigma_t$

2. When the shaft is subjected to an axial load ( $P$ ) in addition to bending and twisting moments as in the propeller shafts of ship and shafts for driving worm gears, then the stress due to axial load must be added to the bending stress ( $\sigma_b$ ). This will give the resultant tensile stress or compressive stress ( $\sigma_t$  or  $\sigma_c$ ) depending upon the type of axial load (*i.e.* pull or push).

Problem:

A shaft, as shown in Fig., is subjected to a bending load of 3 kN, pure torque of 1000 N-m and an axial pulling force of 15 kN. Calculate the stresses at A and B.

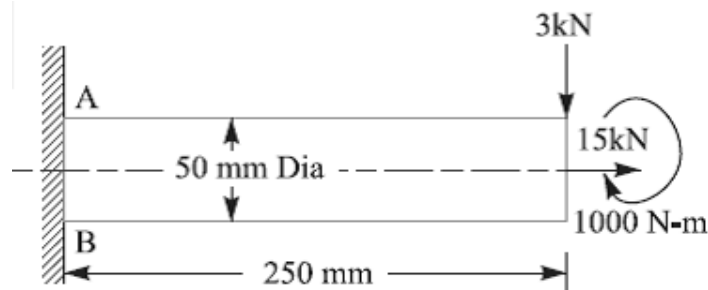



**Solution.** Given :  $W = 3 \text{ kN} = 3000 \text{ N}$  ;  
 $T = 1000 \text{ N-m} = 1 \times 10^6 \text{ N-mm}$  ;  $P = 15 \text{ kN}$   
 $= 15 \times 10^3 \text{ N}$  ;  $d = 50 \text{ mm}$  ;  $x = 250 \text{ mm}$

We know that cross-sectional area of the shaft,

$$A = \frac{\pi}{4} \times d^2$$

$$= \frac{\pi}{4} (50)^2 = 1964 \text{ mm}^2$$

∴ Tensile stress due to axial pulling at points  $A$  and  $B$ ,

$$\sigma_o = \frac{P}{A} = \frac{15 \times 10^3}{1964} = 7.64 \text{ N/mm}^2 = 7.64 \text{ MPa}$$

Bending moment at points  $A$  and  $B$ ,

$$M = W \cdot x = 3000 \times 250 = 750 \times 10^3 \text{ N-mm}$$

Section modulus for the shaft,

$$Z = \frac{\pi}{32} \times d^3 = \frac{\pi}{32} (50)^3$$

$$= 12.27 \times 10^3 \text{ mm}^3$$

∴ Bending stress at points  $A$  and  $B$ ,

$$\sigma_b = \frac{M}{Z} = \frac{750 \times 10^3}{12.27 \times 10^3}$$

$$= 61.1 \text{ N/mm}^2 = 61.1 \text{ MPa}$$

This bending stress is tensile at point  $A$  and compressive at point  $B$ .

∴ Resultant tensile stress at point  $A$ ,

$$\sigma_A = \sigma_b + \sigma_o = 61.1 + 7.64$$

$$= 68.74 \text{ MPa}$$

and resultant compressive stress at point  $B$ ,

$$\sigma_B = \sigma_b - \sigma_o = 61.1 - 7.64 = 53.46 \text{ MPa}$$

We know that the shear stress at points  $A$  and  $B$  due to the torque transmitted,

$$\tau = \frac{16 T}{\pi d^3} = \frac{16 \times 1 \times 10^6}{\pi (50)^3} = 40.74 \text{ N/mm}^2 = 40.74 \text{ MPa} \quad \dots \left( \because T = \frac{\pi}{16} \times \tau \times d^3 \right)$$

**Stresses at point A**

We know that maximum principal (or normal) stress at point A,

$$\begin{aligned}\sigma_{A(max)} &= \frac{\sigma_A}{2} + \frac{1}{2} \left[ \sqrt{(\sigma_A)^2 + 4 \tau^2} \right] \\ &= \frac{68.74}{2} + \frac{1}{2} \left[ \sqrt{(68.74)^2 + 4 (40.74)^2} \right] \\ &= 34.37 + 53.3 = 87.67 \text{ MPa (tensile) Ans.}\end{aligned}$$

Minimum principal (or normal) stress at point A,

$$\begin{aligned}\sigma_{A(min)} &= \frac{\sigma_A}{2} - \frac{1}{2} \left[ \sqrt{(\sigma_A)^2 + 4 \tau^2} \right] = 34.37 - 53.3 = -18.93 \text{ MPa} \\ &= 18.93 \text{ MPa (compressive) Ans.}\end{aligned}$$

and maximum shear stress at point A,

$$\begin{aligned}\tau_{A(max)} &= \frac{1}{2} \left[ \sqrt{(\sigma_A)^2 + 4 \tau^2} \right] = \frac{1}{2} \left[ \sqrt{(68.74)^2 + 4 (40.74)^2} \right] \\ &= 53.3 \text{ MPa Ans.}\end{aligned}$$

**Stresses at point B**

We know that maximum principal (or normal) stress at point B,

$$\begin{aligned}\sigma_{B(max)} &= \frac{\sigma_B}{2} + \frac{1}{2} \left[ \sqrt{(\sigma_B)^2 + 4 \tau^2} \right] \\ &= \frac{53.46}{2} + \frac{1}{2} \left[ \sqrt{(53.46)^2 + 4 (40.74)^2} \right] \\ &= 26.73 + 48.73 = 75.46 \text{ MPa (compressive) Ans.}\end{aligned}$$

Minimum principal (or normal) stress at point B,

$$\begin{aligned}\sigma_{B(min)} &= \frac{\sigma_B}{2} - \frac{1}{2} \left[ \sqrt{(\sigma_B)^2 + 4 \tau^2} \right] \\ &= 26.73 - 48.73 = -22 \text{ MPa} \\ &= 22 \text{ MPa (tensile) Ans.}\end{aligned}$$

and maximum shear stress at point B,

$$\begin{aligned}\tau_{B(max)} &= \frac{1}{2} \left[ \sqrt{(\sigma_B)^2 + 4 \tau^2} \right] = \frac{1}{2} \left[ \sqrt{(53.46)^2 + 4 (40.74)^2} \right] \\ &= 48.73 \text{ MPa Ans.}\end{aligned}$$

**References:**

1. Machine Design - V.Bandari .
2. Machine Design – R.S. Khurmi
3. Design Data hand Book - S MD Jalaludin.

**Factor of Safety**

It is defined, in general, as the **ratio of the maximum stress to the working stress**.

Mathematically,

$$\text{Factor of safety} = \text{Maximum stress} / \text{Working or design stress}$$

In case of ductile materials *e.g.* mild steel, where the yield point is clearly defined, the factor of safety is based upon the yield point stress. In such cases,

$$\text{Factor of safety} = \text{Yield point stress} / \text{Working or design stress}$$

In case of brittle materials *e.g.* cast iron, the yield point is not well defined as for ductile materials. Therefore, the factor of safety for brittle materials is based on ultimate stress.

$$\text{Factor of safety} = \text{Ultimate stress} / \text{Working or design stress}$$

This relation may also be used for ductile materials.

The above relations for factor of safety are for static loading.

**Design for strength and rigidity:****Design for strength:**

All the concepts discussed so far and the problems done are strength based, i.e., there will be some permissible stress or strength and our task is to limit the stresses below the given permissible value and accordingly sizing the machine element.

**Design for rigidity or stiffness:**

It is the ability to resist deformations under the action of external load. Along with strength, rigidity is also very important operating property of many machine components. Ex: helical and leaf springs, elastic elements in various instruments, shafts, bearings, toothed and worm gears and so on.

In many cases, this parameter of operating capacity proves to be most important and to ensure it the dimensions of the part have to be increased to such an extent that the actual induced stresses become much lower than the allowable ones. Rigidity is also necessary to ensure that the mated parts and the machine as a whole operate effectively.

Forces subject the parts to elastic deformations: shafts are bent and twisted, bolts are stretched etc.,

1. When a shaft is deflected, its journals are misaligned in the bearings thereby causing the uneven wear of the shells, heating and seizure in the sliding bearings.
2. Deflections and angles of turn of shafts at the places where gears are fitted cause non-uniform load distribution over the length of the teeth.

3. With the deflection of an insufficiently rigid shaft, the operating conditions or antifriction bearings sharply deteriorate if the bearings cannot self aligning.
4. Rigidity is particularly important for ensuring the adequate accuracy of items produced on machine tools.

Rigidity of machine elements is found with the help of formulae from the theory of strength of materials. The actual displacements like deflections, angles of turn, angles of twist should not be more than the allowable values. The most important design methods for increasing the rigidity of machine elements are as follows.

- a) The decrease in the arms of bending and twisting forces.
- b) The incorporation of additional supports.
- c) The application of cross sections which effectively resist torsion (closed tubular) and bending (in which the cross section is removed as far as possible from the neutral axis).
- d) The decrease of the length of the parts in tension and the increase of their cross section area.

From the above it's clear that the stiffness of a member depends not only on the shape and size of its cross section but also on elastic modulus of the material used.

### Preferred Numbers

When a machine is to be made in several sizes with different powers or capacities, it is necessary to decide what capacities will cover a certain range efficiently with minimum number of sizes. It has been shown by experience that a certain range can be covered efficiently when it follows a geometrical progression with a constant ratio. The preferred numbers are the conventionally rounded off values derived from geometric series including the integral powers of 10 and having as common ratio of the following factors:

$$\sqrt[5]{10}, \sqrt[10]{10}, \sqrt[20]{10}, \sqrt[40]{10}$$

These ratios are approximately equal to 1.58, 1.26, 1.12 and 1.06. The series of preferred numbers are designated as \*R5, R10, R20 and R40 respectively. These four series are called *basic series*. The other series called *derived series* may be obtained by simply multiplying or dividing the basic sizes by 10, 100, etc. The preferred numbers in the series R5 are 1, 1.6, 2.5, 4.0 and 6.3.

### References:

1. Machine Design - V.Bandari .
2. Machine Design – R.S. Khurmi

3. Design Data hand Book - S MD Jalaludin.



**The concept of stiffness in tension, bending, torsion, and combined situations**

**Stiffness in tension:**

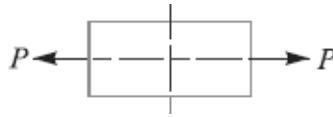

$$\epsilon = \frac{\sigma}{E} = \frac{F/A}{E} = \frac{F}{E} \frac{1}{A} = \frac{F}{E} \frac{1}{\frac{\pi}{4}d^2}$$

$\delta l$  may be a constraint or  $\delta A$  may be a constraint

**Stiffness in Bending:**

$\delta, d, \theta$  may be constraints

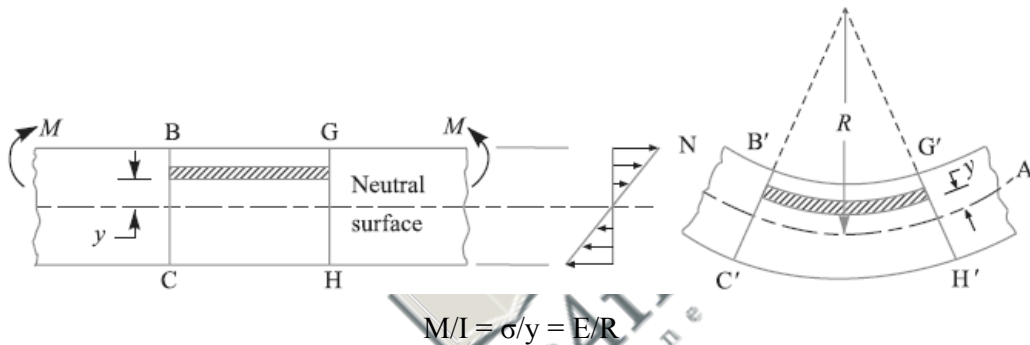

**Stiffness in Torsion:**

$\theta$  may be a constraint.

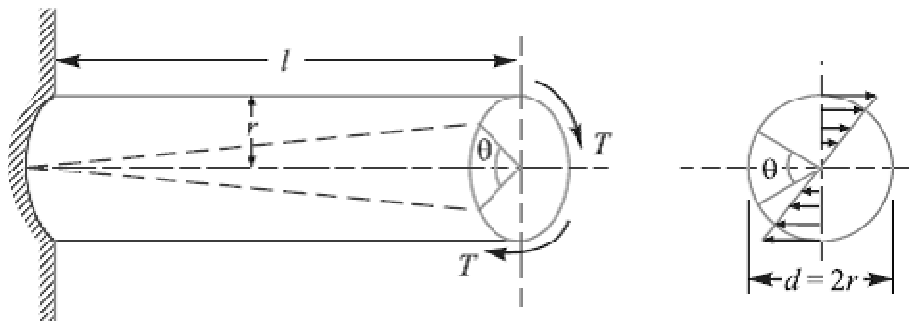

$$T/J = \tau/r = G\theta/l$$

**Combined situations:**

$\sigma_1, \sigma_2,$  and  $\tau_{max}$  any one or two may be constrains. Then control the elements of the formulae like  $\sigma, \tau$  by adjusting the geometry of the machine element or changing the type of material used which changes  $E$ .

$$\sigma_{f1} = \frac{\sigma_1 + \sigma_2}{2} + \frac{1}{2} \sqrt{(\sigma_1 - \sigma_2)^2 + 4 \tau^2}$$

$$\sigma_{r2} = \frac{\sigma_1 + \sigma_2}{2} - \frac{1}{2} \sqrt{(\sigma_1 - \sigma_2)^2 + 4 \tau^2}$$
$$\tau_{max} = \frac{\sigma_1 - \sigma_2}{2} = \frac{1}{2} \sqrt{(\sigma_1 - \sigma_2)^2 + 4 \tau^2}$$

**References:**

1. Machine Design - V.Bandari .
2. Machine Design – R.S. Khurmi
3. Design Data hand Book - S MD Jalaludin



**Fracture Toughness**

Fracture toughness is an indication of the amount of stress required to propagate a preexisting flaw. It is a very important material property since the occurrence of flaws is not completely avoidable in the processing, fabrication, or service of a material/component. Flaws may appear as cracks, voids, metallurgical inclusions, weld defects, design discontinuities, or some combination thereof. Since engineers can never be totally sure that a material is flaw free, it is common practice to assume that a flaw of some chosen size will be present in some number of components and use the linear elastic fracture mechanics (LEFM) approach to design critical components. This approach uses the flaw size and features, component geometry, loading conditions and the material property called fracture toughness to evaluate the ability of a component containing a flaw to resist fracture.

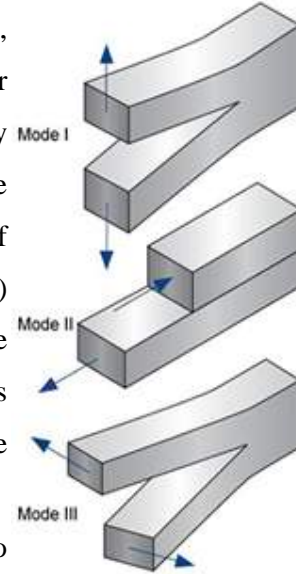

A parameter called the stress-intensity factor ( $K$ ) is used to determine the fracture toughness of most materials. A Roman numeral subscript indicates the mode of fracture and the three modes of fracture are illustrated in the image to the right. Mode I fracture is the condition in which the crack plane is normal to the direction of largest tensile loading. This is the most commonly encountered mode and, therefore, for the remainder of the material we will consider  $K_I$

The stress intensity factor is a function of loading, crack size, and structural geometry. The stress intensity factor may be represented by the following equation:

$$K_I = \sigma \sqrt{\pi a \beta}$$

- Where:
- $K_I$  is the fracture toughness in  $MPa\sqrt{m}$  ( $psi\sqrt{in}$ )
  - $\sigma$  is the applied stress in MPa or psi
  - $a$  is the crack length in meters or inches
  - $\beta$  is a crack length and component geometry factor that is different for each specimen and is dimensionless.



**Role of Material Thickness**

Specimens having standard proportions but different absolute size produce different values for  $K_I$ . This results because the stress states adjacent to the flaw changes with the specimen thickness (B) until the thickness exceeds some critical dimension. Once the thickness exceeds the critical dimension, the value of  $K_I$  becomes relatively constant and this value,  $K_{IC}$ , is a true material property which is called the plane-strain fracture toughness. The relationship between stress intensity,  $K_I$ , and fracture toughness,  $K_{IC}$ , is similar to the relationship between stress and tensile stress. The stress intensity,  $K_I$ , represents the level of “stress” at the tip of the crack and the fracture toughness,  $K_{IC}$ , is the

highest value of stress intensity that a material under very specific (plane-strain) conditions that a material can withstand without fracture. As the stress intensity factor reaches the  $K_{IC}$  value, unstable fracture occurs. As with a material’s other mechanical properties,  $K_{IC}$  is commonly reported in reference books and other sources.

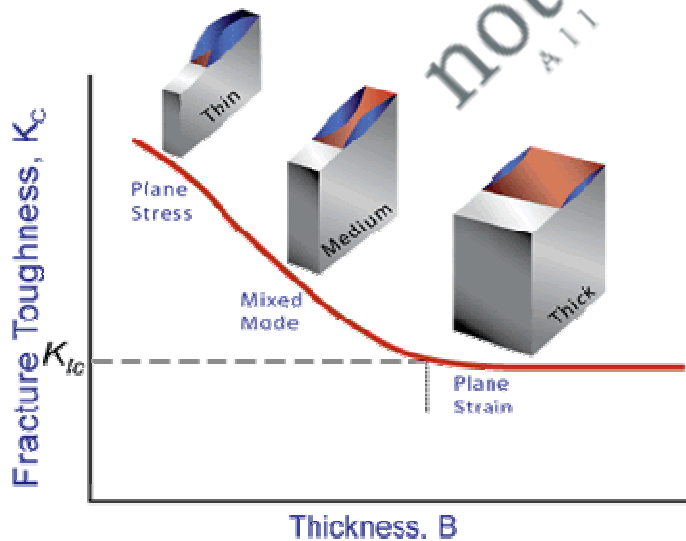
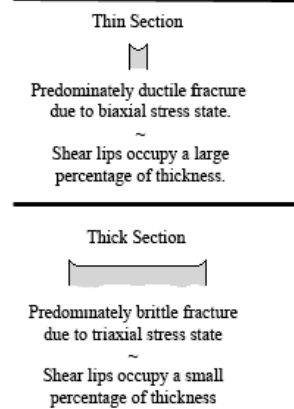
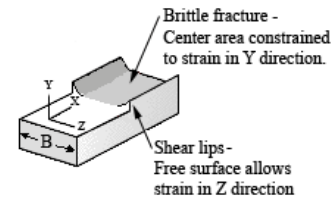

**Plane Strain** - a condition of a body in which the displacements of all points in the body are parallel to a given plane, and the values of these displacements do not depend on the distance perpendicular to the plane

**Plane Stress** – a condition of a body in which the state of stress is such that two of the principal stresses are always parallel to a given plane and are constant in the normal direction.

### Plane-Strain and Plane-Stress

When a material with a crack is loaded in tension, the materials develop plastic strains as the yield stress is exceeded in the region near the crack tip. Material within the crack tip stress field, situated close to a free surface, can deform laterally (in the z-direction of the image) because there can be no stresses normal to the free surface. The state of stress tends to biaxial and the material fractures in a characteristic ductile manner, with a 45° shear lip being formed at each free surface. This condition is called “plane-stress” and it occurs in relatively thin bodies where the stress through the thickness cannot vary appreciably due to the thin section. However, material away from the free surfaces of a relatively thick component is not free to deform laterally as it is constrained by the surrounding material. The stress state under these conditions tends to triaxial and there is zero strain perpendicular to both the stress axis and the direction of crack propagation when a material is loaded in tension. This condition is called “plane-strain” and is found in thick plates. Under plane-strain conditions, materials behave essentially elastic until the fracture stress is reached and then rapid fracture occurs. Since little or no plastic deformation is noted, this mode fracture is termed brittle fracture.

### Plane-Strain Fracture Toughness Testing

When performing a fracture toughness test, the most common test specimen configurations are the single edge notch bend (SENB or three-point bend), and the compact tension (CT) specimens. From the above discussion, it is clear that an accurate determination of the plane-strain fracture toughness requires a specimen whose thickness exceeds some critical thickness (B). Testing has shown that plane-strain conditions generally prevail when:

$$B \geq 2.5 \left( \frac{K_{IC}}{\sigma_y} \right)^2$$

Where: B is the minimum thickness that produces a condition where plastic strain energy at the crack tip is minimal  
 $K_{IC}$  is the fracture toughness of the material  
 $\sigma_y$  is the yield stress of material

When a material of unknown fracture toughness is tested, a specimen of full material section thickness is tested or the specimen is sized based on a prediction of the fracture toughness. If the fracture toughness value resulting from the test does not satisfy the requirement of the above equation, the test must be repeated using a thicker specimen. In addition to this thickness calculation, test specifications have several other requirements that must be met (such as the size of the shear lips) before a test can be said to have resulted in a  $K_{IC}$  value.

When a test fails to meet the thickness and other test requirement that are in place to insure plane-strain condition, the fracture toughness values produced is given the designation  $K_C$ . Sometimes it is not possible to produce a specimen that meets the thickness requirement. For example when a relatively thin plate product with high toughness is being tested, it might not be possible to produce a thicker specimen with plain-strain conditions at the crack tip.

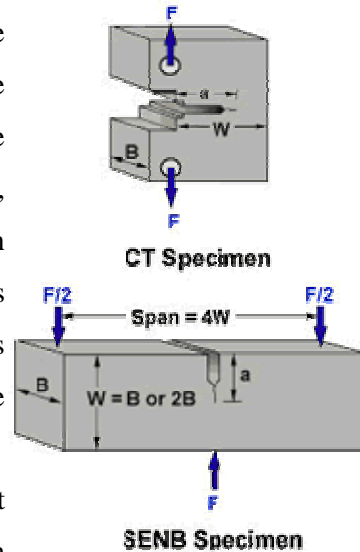

### ***Plane-Stress and Transitional-Stress States***

For cases where the plastic energy at the crack tip is not negligible, other fracture mechanics parameters, such as the J integral or R-curve, can be used to characterize a material. The toughness data produced by these other tests will be dependant on the thickness of the product tested and will not be a true material property. However, plane-strain conditions do not exist in all structural configurations and using  $K_{IC}$  values in the design of relatively thin areas may result in excess conservatism and a weight or cost penalty. In cases where the actual stress state is plane-stress or, more generally, some intermediate- or transitional-stress state, it is more appropriate to use J integral or R-curve data, which account for slow, stable fracture (ductile tearing) rather than rapid (brittle) fracture.

### **Uses of Plane-Strain Fracture Toughness**

$K_{IC}$  values are used to determine the critical crack length when a given stress is applied to a component.

$$\sigma_c \leq \frac{K_{IC}}{Y\sqrt{\pi a}}$$

Where:  $s_c$  is the critical applied stress that will cause failure

$K_{IC}$  is the plane-strain fracture toughness

$Y$  is a constant related to the sample's geometry

$a$  is the crack length for edge cracks  
or one half crack length for internal crack

$K_{IC}$  values are used also used to calculate the critical stress value when a crack of a given length is found in a component.

$$a_c = \frac{1}{\pi} \left( \frac{K_{IC}}{\sigma Y} \right)^2$$

Where:  $a$  is the crack length for edge cracks  
or one half crack length for internal crack

$s$  is the stress applied to the material

$K_{IC}$  is the plane-strain fracture toughness

$Y$  is a constant related to the sample's geometry

### Orientation

The fracture toughness of a material commonly varies with grain direction. Therefore, it is customary to specify specimen and crack orientations by an ordered pair of grain direction symbols. The first letter designates the grain direction normal to the crack plane. The second letter designates the grain direction parallel to the fracture plane. For flat sections of various products, e.g., plate, extrusions, forgings, etc., in which the three grain directions are designated (L) longitudinal, (T) transverse, and (S) short transverse, the six principal fracture path directions are: L-T, L-S, T-L, T-S, S-L and S-T.

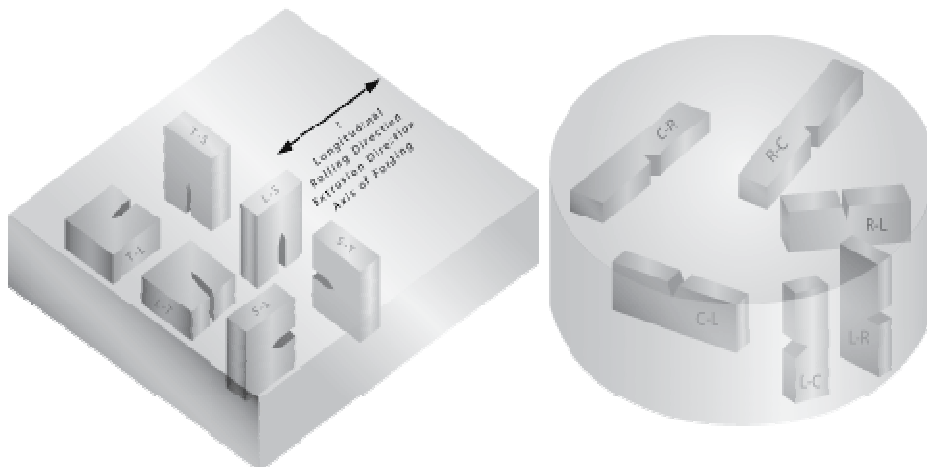

**References:**

1. Machine Design - V.Bandari .
2. Machine Design – R.S. Khurmi
3. Web sources.



**Stress Concentration:**

Whenever a machine component changes the shape of its cross-section, the simple stress distribution no longer holds good and the neighborhood of the discontinuity is different. This irregularity in the stress distribution caused by abrupt changes of form is called **stress concentration**. It occurs for all kinds of stresses in the presence of fillets, notches, holes, keyways, splines, surface roughness or scratches etc. In order to understand fully the idea of stress concentration, consider a member with different cross-section under a tensile load as shown in Fig. A little consideration will show that the nominal stress in the right and left hand sides will be uniform but in the region where the cross-section is changing, a redistribution of the force within the member must take place. The material near the edges is stressed considerably higher than the average value. The maximum stress occurs at some point on the fillet and is directed parallel to the boundary at that point.

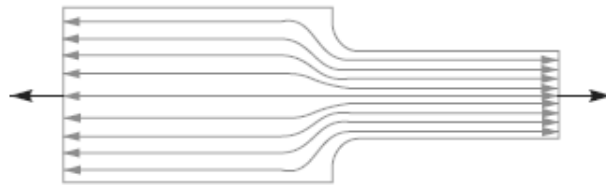

Fig. Stress concentration

**Theoretical or Form Stress Concentration Factor**

The theoretical or form stress concentration factor is defined as the ratio of the maximum stress in a member (at a notch or a fillet) to the nominal stress at the same section based upon net area. Mathematically, theoretical or form stress concentration factor,

$$K_t = \text{Maximum stress} / \text{Nominal stress}$$

The value of  $K_t$  depends upon the material and geometry of the part. In static loading, stress concentration in ductile materials is not so serious as in brittle materials, because in ductile materials local deformation or yielding takes place which reduces the concentration. In brittle materials, cracks may appear at these local concentrations of stress which will increase the stress over the rest of the section. It is, therefore, necessary that in designing parts of brittle materials such as castings, care should be taken. In order to avoid failure due to stress concentration, fillets at the changes of section must be provided.

In cyclic loading, stress concentration in ductile materials is always serious because the ductility of the material is not effective in relieving the concentration of stress caused by cracks, flaws, surface roughness, or any sharp discontinuity in the geometrical form of the member. If the stress at any point in a member is above the endurance limit of the material, a

crack may develop under the action of repeated load and the crack will lead to failure of the member.

**Stress Concentration due to Holes and Notches**

Consider a plate with transverse elliptical hole and subjected to a tensile load as shown in Fig.1(a). We see from the stress-distribution that the stress at the point away from the hole is practically uniform and the maximum stress will be induced at the edge of the hole. The maximum stress is given by

$$\sigma_{max} = \sigma \left( 1 + \frac{2a}{b} \right)$$

And the theoretical stress concentration factor,

$$K_t = \frac{\sigma_{max}}{\sigma} = \left( 1 + \frac{2a}{r} \right)$$

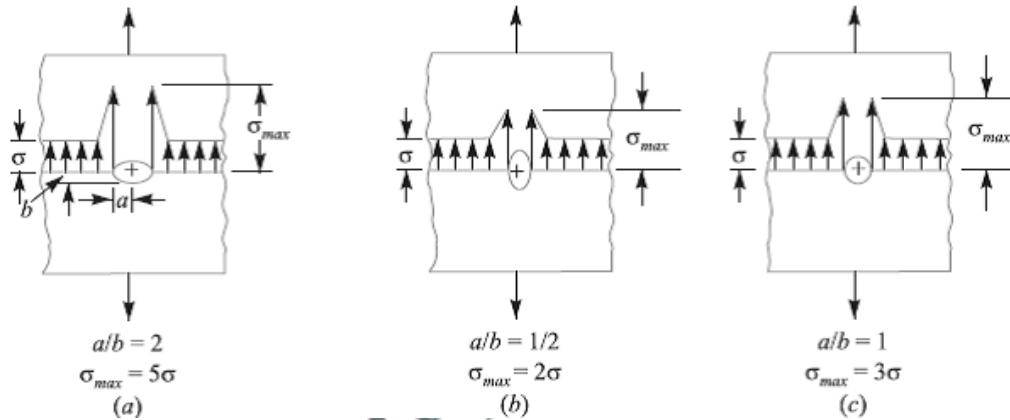

Fig.1. Stress concentration due to holes.

The stress concentration in the notched tension member, as shown in Fig. 2, is influenced by the depth *a* of the notch and radius *r* at the bottom of the notch. The maximum stress, which applies to members having notches that are small in comparison with the width of the plate, may be obtained by the following equation,

$$\sigma_{max} = \sigma \left( 1 + \frac{2a}{r} \right)$$

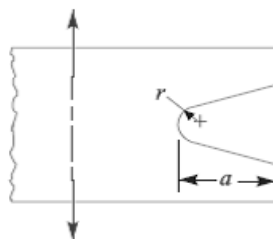

Fig.2. Stress concentration due to notches.

**Methods of Reducing Stress Concentration**

Whenever there is a change in cross-section, such as shoulders, holes, notches or keyways and where there is an interference fit between a hub or bearing race and a shaft, then stress concentration results. The presence of stress concentration can not be totally eliminated but it may be reduced to some extent. A device or concept that is useful in assisting a design engineer to visualize the presence of stress concentration and how it may be mitigated is that of stress flow lines, as shown in Fig.3. The mitigation of stress concentration means that the stress flow lines shall maintain their spacing as far as possible.

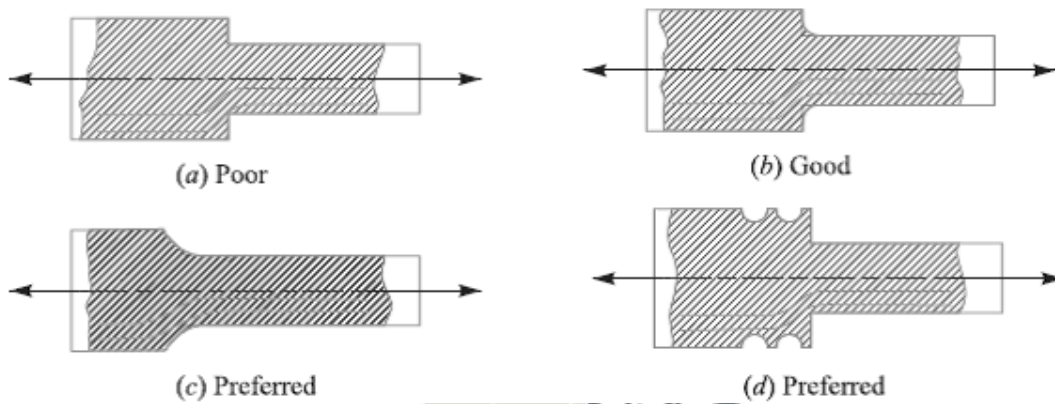

Fig.3

In Fig. 3 (a) we see that stress lines tend to bunch up and cut very close to the sharp re-entrant corner. In order to improve the situation, fillets may be provided, as shown in Fig. 3 (b) and (c) to give more equally spaced flow lines.

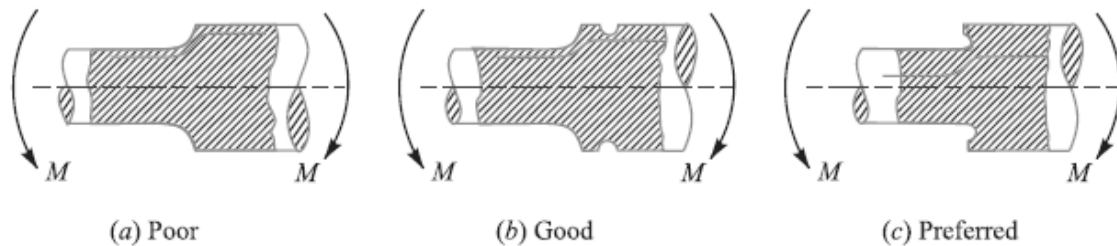

Fig. reducing stress concentration in cylindrical members with shoulders



Fig. Reducing stress concentration in cylindrical members with holes.



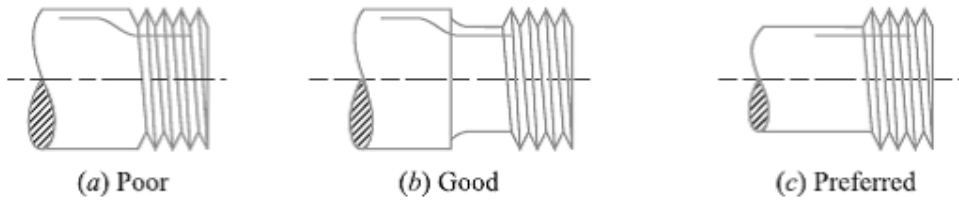

Fig. Reducing stress concentration in cylindrical members with holes

**References:**

1. Machine Design - V.Bandari .
2. Machine Design – R.S. Khurmi
3. Design Data hand Book - S MD Jalaludin



### Completely Reversed or Cyclic Stresses

Consider a rotating beam of circular cross-section and carrying a load  $W$ , as shown in Fig1. This load induces stresses in the beam which are cyclic in nature. A little consideration will show that the upper fibres of the beam (*i.e.* at point  $A$ ) are under compressive stress and the lower fibres (*i.e.* at point  $B$ ) are under tensile stress. After half a revolution, the point  $B$  occupies the position of point  $A$  and the point  $A$  occupies the position of point  $B$ . Thus the point  $B$  is now under compressive stress and the point  $A$  under tensile stress. The speed of variation of these stresses depends upon the speed of the beam.

From above we see that for each revolution of the beam, the stresses are reversed from compressive to tensile. The stresses which vary from one value of compressive to the same value of tensile or *vice versa*, are known as **completely reversed** or **cyclic stresses**. The stresses which vary from a minimum value to a maximum value of the same nature, (*i.e.* tensile or compressive) are called **fluctuating stresses**. The stresses which vary from zero to a certain maximum value are called **repeated stresses**. The stresses which vary from a minimum value to a maximum value of the opposite nature (*i.e.* from a certain minimum compressive to a certain maximum tensile or from a minimum tensile to a maximum compressive) are called **alternating stresses**.

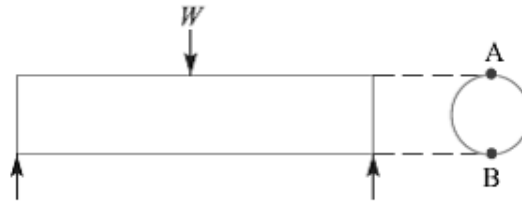

Fig.1. Shaft subjected to cyclic load

### Fatigue and Endurance Limit

It has been found experimentally that when a material is subjected to repeated stresses; it fails at stresses below the yield point stresses. Such type of failure of a material is known as **fatigue**. The failure is caused by means of a progressive crack formation which are usually fine and of microscopic size. The failure may occur even without any prior indication. The fatigue of material is effected by the size of the component, relative magnitude of static and fluctuating loads and the number of load reversals.

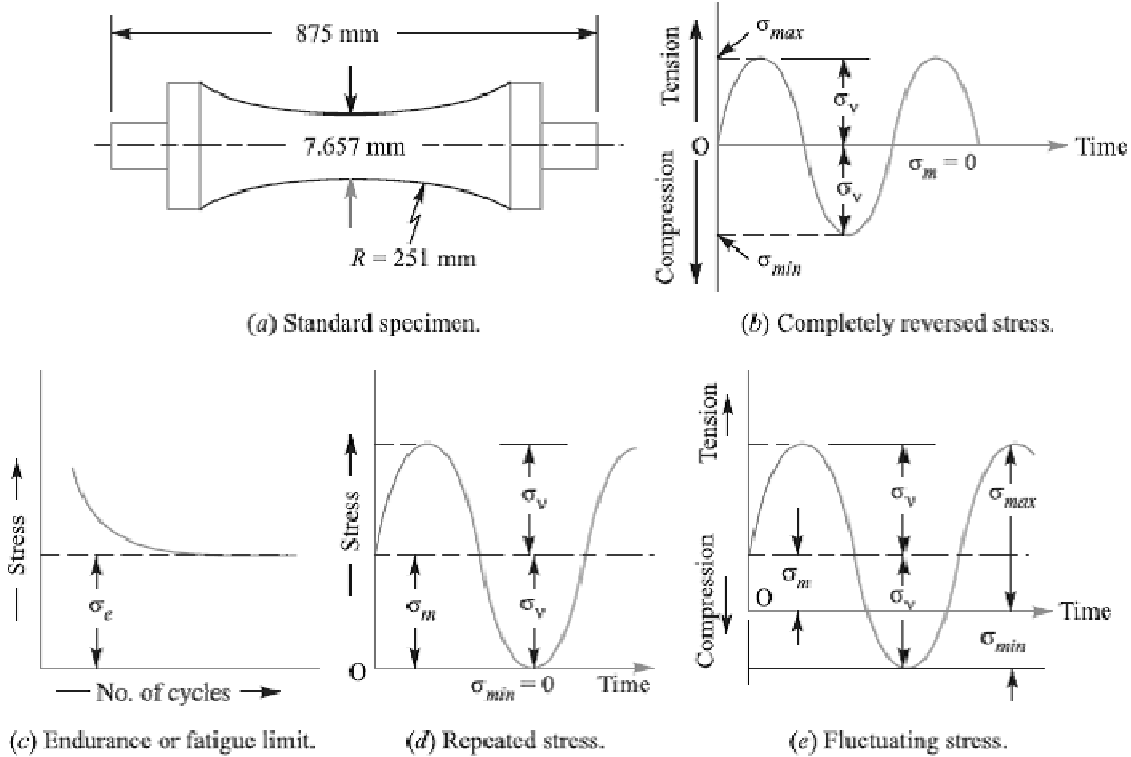

Fig.2. Time-stress diagrams.

In order to study the effect of fatigue of a material, a rotating mirror beam method is used. In this method, a standard mirror polished specimen, as shown in Fig.2 (a), is rotated in a fatigue testing machine while the specimen is loaded in bending. As the specimen rotates, the bending stress at the upper fibres varies from maximum compressive to maximum tensile while the bending stress at the lower fibres varies from maximum tensile to maximum compressive. In other words, the specimen is subjected to a completely reversed stress cycle. This is represented by a time-stress diagram as shown in Fig.2 (b). A record is kept of the number of cycles required to produce failure at a given stress, and the results are plotted in stress-cycle curve as shown in Fig.2 (c). A little consideration will show that if the stress is kept below a certain value as shown by dotted line in Fig.2 (c), the material will not fail whatever may be the number of cycles. This stress, as represented by dotted line, is known as **endurance** or **fatigue limit** ( $\sigma_e$ ). It is defined as maximum value of the completely reversed bending stress which a polished standard specimen can withstand without failure, for infinite number of cycles (usually 107 cycles).

It may be noted that the term endurance limit is used for reversed bending only while for other types of loading, the term **endurance strength** may be used when referring the

fatigue strength of the material. It may be defined as the safe maximum stress which can be applied to the machine part working under actual conditions.

We have seen that when a machine member is subjected to a completely reversed stress, the maximum stress in tension is equal to the maximum stress in compression as shown in Fig.2 (b). In actual practice, many machine members undergo different range of stress than the completely reversed stress. The stress *verses* time diagram for fluctuating stress having values  $\sigma_{min}$  and  $\sigma_{max}$  is shown in Fig.2 (e). The variable stress, in general, may be considered as a combination of steady (or mean or average) stress and a completely reversed stress component  $\sigma_v$ . The following relations are derived from Fig. 2 (e):

1. Mean or average stress,

$$\sigma_m = \frac{\sigma_{max} + \sigma_{min}}{2}$$

2. Reversed stress component or alternating or variable stress,

$$\sigma_v = \frac{\sigma_{max} - \sigma_{min}}{2}$$

For repeated loading, the stress varies from maximum to zero (*i.e.*  $\sigma_{min} = 0$ ) in each cycle as shown in Fig.2 (d).

$$\sigma_m = \sigma_v = \frac{\sigma_{max}}{2}$$

3. Stress ratio,  $R = \sigma_{max}/\sigma_{min}$ . For completely reversed stresses,  $R = -1$  and for repeated stresses,  $R = 0$ . It may be noted that  $R$  cannot be greater than unity.

4. The following relation between endurance limit and stress ratio may be used

$$\sigma'_e = \frac{3\sigma_e}{2 - R}$$

### Effect of Loading on Endurance Limit—Load Factor

The endurance limit ( $\sigma_e$ ) of a material as determined by the rotating beam method is for reversed bending load. There are many machine members which are subjected to loads other than reversed bending loads. Thus the endurance limit will also be different for different types of loading. The endurance limit depending upon the type of loading may be modified as discussed below:

Let  $K_b$  = Load correction factor for the reversed or rotating bending load. Its value is usually taken as unity.

$K_a$  = Load correction factor for the reversed axial load. Its value may be taken as 0.8.

$K_s$  = Load correction factor for the reversed torsional or shear load. Its value may be taken as 0.55 for ductile materials and 0.8 for brittle materials.

$$\begin{aligned} \therefore \text{Endurance limit for reversed bending load,} & \quad \sigma_{eb} = \sigma_e K_b = \sigma_e \\ \text{Endurance limit for reversed axial load,} & \quad \sigma_{ea} = \sigma_e K_a \\ \text{and endurance limit for reversed torsional or shear load,} & \quad \tau_e = \sigma_e K_s \end{aligned}$$

**Effect of Surface Finish on Endurance Limit—Surface Finish Factor**

When a machine member is subjected to variable loads, the endurance limit of the material for that member depends upon the surface conditions. Fig. shows the values of surface finish factor for the various surface conditions and ultimate tensile strength.

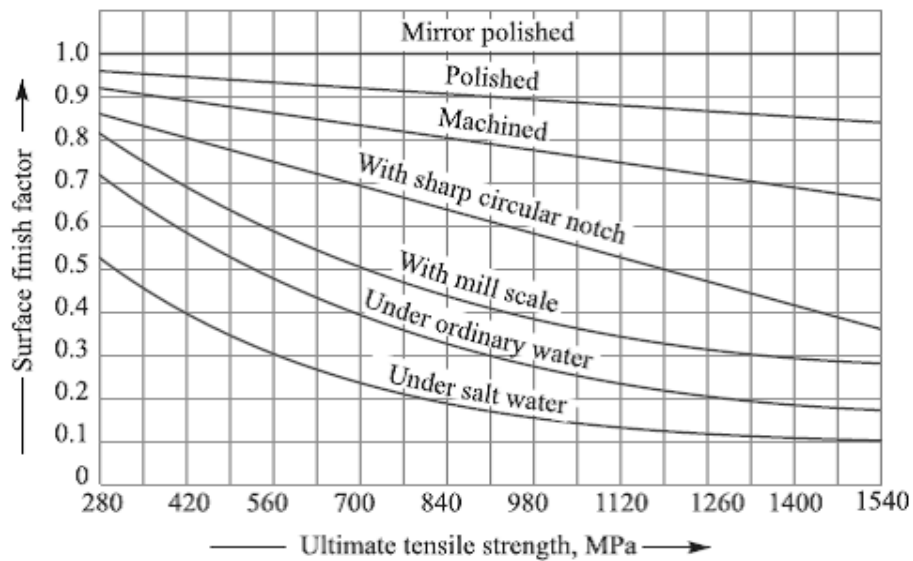

When the surface finish factor is known, then the endurance limit for the material of the machine member may be obtained by multiplying the endurance limit and the surface finish factor. We see that for a mirror polished material, the surface finish factor is unity. In other words, the endurance limit for mirror polished material is maximum and it goes on reducing due to surface condition.

Let  $K_{sur}$  = Surface finish factor.

Then, Endurance limit,

$$\begin{aligned} \sigma_{e1} &= \sigma_{eb} \cdot K_{sur} = \sigma_e \cdot K_b \cdot K_{sur} = \sigma_e \cdot K_{sur} && \dots (\because K_b = 1) \\ & && \dots (\text{For reversed bending load}) \\ &= \sigma_{ea} \cdot K_{sur} = \sigma_e \cdot K_a \cdot K_{sur} && \dots (\text{For reversed axial load}) \\ &= \tau_e \cdot K_{sur} = \sigma_e \cdot K_s \cdot K_{sur} && \dots (\text{For reversed torsional or shear load}) \end{aligned}$$

**Effect of Size on Endurance Limit—Size Factor**

A little consideration will show that if the size of the standard specimen as shown in Fig.2 (a) is increased, then the endurance limit of the material will decrease. This is due to the fact that a longer specimen will have more defects than a smaller one.

Let  $K_{sz}$  = Size factor.

Then, Endurance limit,

$$\begin{aligned} \sigma_{e2} &= \sigma_{e1} \times K_{sz} && \dots(\text{Considering surface finish factor also}) \\ &= \sigma_{eb} \cdot K_{sur} \cdot K_{sz} = \sigma_e \cdot K_b \cdot K_{sur} \cdot K_{sz} = \sigma_e \cdot K_{sur} \cdot K_{sz} && (\because K_b = 1) \\ &= \sigma_{ea} \cdot K_{sur} \cdot K_{sz} = \sigma_e \cdot K_a \cdot K_{sur} \cdot K_{sz} && \dots(\text{For reversed axial load}) \\ &= \tau_e \cdot K_{sur} \cdot K_{sz} = \sigma_e \cdot K_s \cdot K_{sur} \cdot K_{sz} && \dots (\text{For reversed torsional or shear load}) \end{aligned}$$

The value of size factor is taken as unity for the standard specimen having nominal diameter of 7.657 mm. When the nominal diameter of the specimen is more than 7.657 mm but less than 50 mm, the value of size factor may be taken as 0.85. When the nominal diameter of the specimen is more than 50 mm, then the value of size factor may be taken as 0.75.

**Effect of Miscellaneous Factors on Endurance Limit**

In addition to the surface finish factor ( $K_{sur}$ ), size factor ( $K_{sz}$ ) and load factors  $K_b$ ,  $K_a$  and  $K_s$ , there are many other factors such as reliability factor ( $K_r$ ), temperature factor ( $K_t$ ), impact factor ( $K_i$ ) etc. which has effect on the endurance limit of a material. Considering all these factors, the endurance limit may be determined by using the following expressions:

1. For the reversed bending load, endurance limit,

$$\sigma'_e = \sigma_{eb} \cdot K_{sur} \cdot K_{sz} \cdot K_r \cdot K_t \cdot K_i$$

2. For the reversed axial load, endurance limit,

$$\sigma'_e = \sigma_{ea} \cdot K_{sur} \cdot K_{sz} \cdot K_r \cdot K_t \cdot K_i$$

3. For the reversed torsional or shear load, endurance limit,

$$\sigma'_e = \tau_e \cdot K_{sur} \cdot K_{sz} \cdot K_r \cdot K_t \cdot K_i$$

In solving problems, if the value of any of the above factors is not known, it may be taken as unity.

**Relation between Endurance Limit and Ultimate Tensile Strength**

It has been found experimentally that endurance limit ( $\sigma_e$ ) of a material subjected to fatigue loading is a function of ultimate tensile strength ( $\sigma_u$ ).

For steel,	$\sigma_e = 0.5 \sigma_u$ ;
For cast steel,	$\sigma_e = 0.4 \sigma_u$ ;
For cast iron,	$\sigma_e = 0.35 \sigma_u$ ;
For non-ferrous metals and alloys,	$\sigma_e = 0.3 \sigma_u$

### Factor of Safety for Fatigue Loading

When a component is subjected to fatigue loading, the endurance limit is the criterion for failure. Therefore, the factor of safety should be based on endurance limit. Mathematically,

$$\text{Factor of safety (F.S.)} = \frac{\text{Endurance limit stress}}{\text{Design or working stress}} = \frac{\sigma_e}{\sigma_d}$$

For steel,  $\sigma_e = 0.8 \text{ to } 0.9 \sigma_y$   
 $\sigma_e$  = Endurance limit stress for completely reversed stress cycle, and  
 $\sigma_y$  = Yield point stress.

### Fatigue Stress Concentration Factor

When a machine member is subjected to cyclic or fatigue loading, the value of fatigue stress concentration factor shall be applied instead of theoretical stress concentration factor. Since the determination of fatigue stress concentration factor is not an easy task, therefore from experimental tests it is defined as

Fatigue stress concentration factor,

$$K_f = \frac{\text{Endurance limit without stress concentration}}{\text{Endurance limit with stress concentration}}$$

### Notch Sensitivity

In cyclic loading, the effect of the notch or the fillet is usually less than predicted by the use of the theoretical factors as discussed before. The difference depends upon the stress gradient in the region of the stress concentration and on the hardness of the material. The term **notch sensitivity** is applied to this behaviour. It may be defined as the degree to which the theoretical effect of stress concentration is actually reached. The stress gradient depends mainly on the radius of the notch, hole or fillet and on the grain size of the material. Since the extensive data for estimating the notch sensitivity factor ( $q$ ) is not available, therefore the curves, as shown in Fig., may be used for determining the values of  $q$  for two steels. When the notch sensitivity factor  $q$  is used in cyclic loading, then fatigue stress concentration factor may be obtained from the following relations:

$$q = \frac{K_f - 1}{K_t - 1}$$

Or

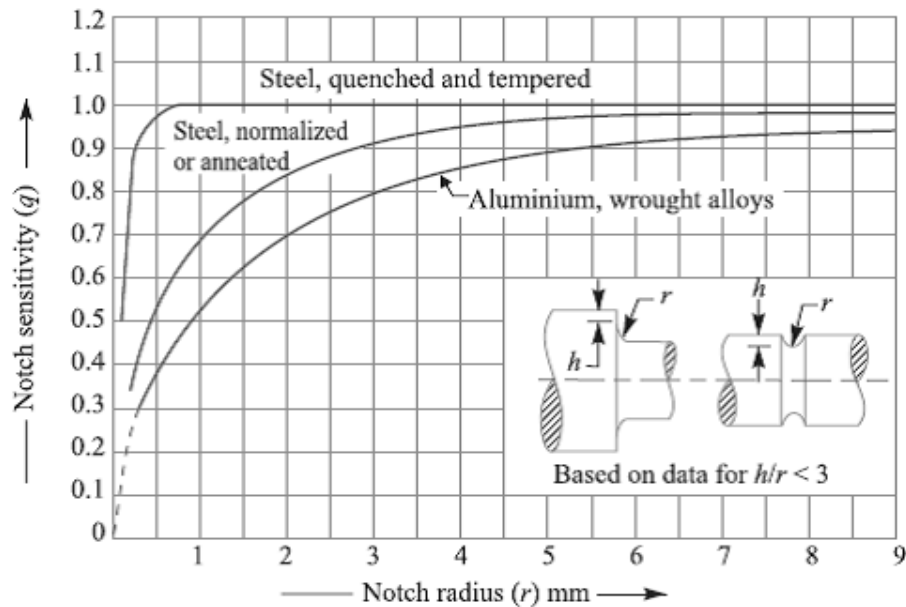

$$K_f = 1 + q (K_t - 1) \quad \dots[\text{For tensile or bending stress}]$$

And

$$K_{fs} = 1 + q (K_{ts} - 1) \quad \dots[\text{For shear stress}]$$

Where  $K_t$  = Theoretical stress concentration factor for axial or bending loading, and  $K_{ts}$  = Theoretical stress concentration factor for torsional or shear loading.

**References:**

1. Machine Design - V.Bandari .
2. Machine Design – R.S. Khurmi
3. Design Data hand Book - S MD Jalaludin.



Problem: Determine the thickness of a 120 mm wide uniform plate for safe continuous operation if the plate is to be subjected to a tensile load that has a maximum value of 250 kN and a minimum value of 100 kN. The properties of the plate material are as follows: Endurance limit stress = 225 MPa, and Yield point stress = 300 MPa. The factor of safety based on yield point may be taken as 1.5.

Let  $t =$  Thickness of the plate in mm.

$$\therefore \text{Area, } A = b \times t = 120 t \text{ mm}^2$$

We know that mean or average load,

$$W_m = \frac{W_{max} + W_{min}}{2} = \frac{250 + 100}{2} = 175 \text{ kN} = 175 \times 10^3 \text{ N}$$

$$\therefore \text{Mean stress, } \sigma_m = \frac{W_m}{A} = \frac{175 \times 10^3}{120t} \text{ N/mm}^2$$

$$\text{Variable load, } W_v = \frac{W_{max} - W_{min}}{2} = \frac{250 - 100}{2} = 75 \text{ kN} = 75 \times 10^3 \text{ N}$$

$$\therefore \text{Variable stress, } \sigma_v = \frac{W_v}{A} = \frac{75 \times 10^3}{120t} \text{ N/mm}^2$$

According to Soderberg's formula,

$$\frac{1}{F.S.} = \frac{\sigma_m}{\sigma_y} + \frac{\sigma_v}{\sigma_e}$$

$$\frac{1}{1.5} = \frac{175 \times 10^3}{120t \times 300} + \frac{75 \times 10^3}{120t \times 225} = \frac{4.86}{t} + \frac{2.78}{t} = \frac{7.64}{t}$$

$$\therefore t = 7.64 \times 1.5 = 11.46 \text{ say } 11.5 \text{ mm Ans.}$$

Problem:

Determine the diameter of a circular rod made of ductile material with a fatigue strength (complete stress reversal),  $\sigma_e = 265$  MPa and a tensile yield strength of 350 MPa. The member is subjected to a varying axial load from  $W_{min} = -300 \times 10^3$  N to  $W_{max} = 700 \times 10^3$  N and has a stress concentration factor = 1.8. Use factor of safety as 2.0.

Let  $d =$  Diameter of the circular rod in mm.

$$\therefore \text{Area, } A = \frac{\pi}{4} \times d^2 = 0.7854 d^2 \text{ mm}^2$$

We know that the mean or average load,

$$W_m = \frac{W_{max} + W_{min}}{2} = \frac{700 \times 10^3 + (-300 \times 10^3)}{2} = 200 \times 10^3 \text{ N}$$

$$\therefore \text{Mean stress, } \sigma_m = \frac{W_m}{A} = \frac{200 \times 10^3}{0.7854 d^2} = \frac{254.6 \times 10^3}{d^2} \text{ N/mm}^2$$

$$\text{Variable load, } W_v = \frac{W_{max} - W_{min}}{2} = \frac{700 \times 10^3 - (-300 \times 10^3)}{2} = 500 \times 10^3 \text{ N}$$

$$\therefore \text{Variable stress, } \sigma_v = \frac{W_v}{A} = \frac{500 \times 10^3}{0.7854 d^2} = \frac{636.5 \times 10^3}{d^2} \text{ N/mm}^2$$

We know that according to Soderberg's formula,

$$\frac{1}{F.S.} = \frac{\sigma_m}{\sigma_y} + \frac{\sigma_v \times K_f}{\sigma_e}$$

$$\frac{1}{2} = \frac{254.6 \times 10^3}{d^2 \times 350} + \frac{636.5 \times 10^3 \times 1.8}{d^2 \times 265} = \frac{727}{d^2} + \frac{4323}{d^2} = \frac{5050}{d^2}$$

$$\therefore d^2 = 5050 \times 2 = 10100 \text{ or } d = 100.5 \text{ mm Ans.}$$

Problem:

A circular bar of 500 mm length is supported freely at its two ends. It is acted upon by a central concentrated cyclic load having a minimum value of 20 kN and a maximum value of 50 kN. Determine the diameter of bar by taking a factor of safety of 1.5, size effect of 0.85, surface finish factor of 0.9. The material properties of bar are given by: ultimate strength of 650 MPa, yield strength of 500 MPa and endurance strength of 350 MPa.

**Solution.** Given :  $l = 500 \text{ mm}$  ;  $W_{min} = 20 \text{ kN} = 20 \times 10^3 \text{ N}$  ;  $W_{max} = 50 \text{ kN} = 50 \times 10^3 \text{ N}$  ;  
 $F.S. = 1.5$  ;  $K_{sz} = 0.85$  ;  $K_{surf} = 0.9$  ;  $\sigma_u = 650 \text{ MPa} = 650 \text{ N/mm}^2$  ;  $\sigma_y = 500 \text{ MPa} = 500 \text{ N/mm}^2$  ;  
 $\sigma_e = 350 \text{ MPa} = 350 \text{ N/mm}^2$

Let  $d =$  Diameter of the bar in mm.

We know that the maximum bending moment,

$$M_{max} = \frac{W_{max} \times l}{4} = \frac{50 \times 10^3 \times 500}{4} = 6250 \times 10^3 \text{ N-mm}$$

and minimum bending moment,

$$M_{min} = \frac{W_{min} \times l}{4} = \frac{20 \times 10^3 \times 500}{4} = 2550 \times 10^3 \text{ N-mm}$$

$\therefore$  Mean or average bending moment,

$$M_m = \frac{M_{max} + M_{min}}{2} = \frac{6250 \times 10^3 + 2550 \times 10^3}{2} = 4400 \times 10^3 \text{ N-mm}$$

and variable bending moment,

$$M_v = \frac{M_{max} - M_{min}}{2} = \frac{6250 \times 10^3 - 2550 \times 10^3}{2} = 1850 \times 10^3 \text{ N-mm}$$

Section modulus of the bar,

$$Z = \frac{\pi}{32} \times d^3 = 0.0982 d^3 \text{ mm}^3$$

$\therefore$  Mean or average bending stress,

$$\sigma_m = \frac{M_m}{Z} = \frac{4400 \times 10^3}{0.0982 d^3} = \frac{44.8 \times 10^6}{d^3} \text{ N/mm}^2$$

and variable bending stress,

$$\sigma_v = \frac{M_v}{Z} = \frac{1875 \times 10^3}{0.0982 d^3} = \frac{19.1 \times 10^6}{d^3} \text{ N/mm}^2$$

We know that according to Goodman's formula,

$$\frac{1}{F.S.} = \frac{\sigma_m}{\sigma_u} + \frac{\sigma_v \times K_f}{\sigma_e \times K_{sur} \times K_{sz}}$$

$$\frac{1}{1.5} = \frac{44.5 \times 10^6}{d^3 \times 650} + \frac{19.1 \times 10^6 \times 1}{d^3 \times 350 \times 0.9 \times 0.85} \quad \dots(\text{Taking } K_f = 1)$$

$$= \frac{68 \times 10^3}{d^3} + \frac{71 \times 10^3}{d^3} = \frac{139 \times 10^3}{d^3}$$

$$\therefore d^3 = 139 \times 10^3 \times 1.5 = 209 \times 10^3 \quad \text{or} \quad d = 59.3 \text{ mm}$$

and according to Soderberg's formula,

$$\frac{1}{F.S.} = \frac{\sigma_m}{\sigma_y} + \frac{\sigma_v \times K_f}{\sigma_e \times K_{sur} \times K_{sz}}$$

$$\frac{1}{1.5} = \frac{44.5 \times 10^6}{d^3 \times 500} + \frac{19.1 \times 10^6 \times 1}{d^3 \times 350 \times 0.9 \times 0.85} \quad \dots(\text{Taking } K_f = 1)$$

$$= \frac{89 \times 10^3}{d^3} + \frac{71 \times 10^3}{d^3} = \frac{160 \times 10^3}{d^3}$$

$$\therefore d^3 = 160 \times 10^3 \times 1.5 = 240 \times 10^3 \quad \text{or} \quad d = 62.1 \text{ mm}$$

Taking larger of the two values, we have  $d = 62.1 \text{ mm}$  Ans.

### References:

1. Machine Design - V.Bandari .
2. Machine Design – R.S. Khurmi
3. Design Data hand Book - S MD Jalaludin.



Problem:

A 50 mm diameter shaft is made from carbon steel having ultimate tensile strength of 630 MPa. It is subjected to a torque which fluctuates between 2000 N-m to – 800 N-m. Using Soderberg method, calculate the factor of safety. Assume suitable values for any other data needed.

Solution. Given :  $d = 50 \text{ mm}$  ;  $\sigma_u = 630 \text{ MPa} = 630 \text{ N/mm}^2$  ;  $T_{max} = 2000 \text{ N-m}$  ;  $T_{min} = -800 \text{ N-m}$   
 We know that the mean or average torque,

$$T_m = \frac{T_{max} + T_{min}}{2} = \frac{2000 + (-800)}{2} = 600 \text{ N-m} = 600 \times 10^3 \text{ N-mm}$$

∴ Mean or average shear stress,

$$\tau_m = \frac{16 T_m}{\pi d^3} = \frac{16 \times 600 \times 10^3}{\pi (50)^3} = 24.4 \text{ N/mm}^2 \quad \dots \left( \because T = \frac{\pi}{16} \times \tau \times d^3 \right)$$

Variable torque,

$$T_v = \frac{T_{max} - T_{min}}{2} = \frac{2000 - (-800)}{2} = 1400 \text{ N-m} = 1400 \times 10^3 \text{ N-mm}$$

∴ Variable shear stress,  $\tau_v = \frac{16 T_v}{\pi d^3} = \frac{16 \times 1400 \times 10^3}{\pi (50)^3} = 57 \text{ N/mm}^2$

Since the endurance limit in reversed bending ( $\sigma_e$ ) is taken as one-half the ultimate tensile strength (i.e.  $\sigma_e = 0.5 \sigma_u$ ) and the endurance limit in shear ( $\tau_e$ ) is taken as  $0.55 \sigma_e$ , therefore

$$\begin{aligned} \tau_e &= 0.55 \sigma_e = 0.55 \times 0.5 \sigma_u = 0.275 \sigma_u \\ &= 0.275 \times 630 = 173.25 \text{ N/mm}^2 \end{aligned}$$

Assume the yield stress ( $\sigma_y$ ) for carbon steel in reversed bending as  $510 \text{ N/mm}^2$ , surface finish factor ( $K_{sm}$ ) as 0.87, size factor ( $K_{sz}$ ) as 0.85 and fatigue stress concentration factor ( $K_f$ ) as 1.

Since the yield stress in shear ( $\tau_y$ ) for shear loading is taken as one-half the yield stress in reversed bending ( $\sigma_y$ ), therefore

$$\tau_y = 0.5 \sigma_y = 0.5 \times 510 = 255 \text{ N/mm}^2$$

Let  $F.S.$  = Factor of safety.

We know that according to Soderberg's formula,

$$\begin{aligned} \frac{1}{F.S.} &= \frac{\tau_m}{\tau_y} + \frac{\tau_v \times K_{fs}}{\tau_e \times K_{sm} \times K_{sz}} = \frac{24.4}{255} + \frac{57 \times 1}{173.25 \times 0.87 \times 0.85} \\ &= 0.096 + 0.445 = 0.541 \end{aligned}$$

∴  $F.S. = 1 / 0.541 = 1.85 \text{ Ans.}$

Problem:

A simply supported beam has a concentrated load at the centre which fluctuates from a value of  $P$  to  $4P$ . The span of the beam is 500 mm and its cross-section is circular with a diameter of 60 mm. Taking for the beam material an ultimate stress of 700 MPa, a yield stress of 500 MPa, endurance limit of 330 MPa for reversed bending, and a factor of safety of 1.3, calculate the maximum value of  $P$ . Take a size factor of 0.85 and a surface finish factor of 0.9.

Solution. Given :  $W_{min} = P$  ;  $W_{max} = 4P$  ;  $L = 500$  mm ;  $d = 60$  mm ;  $\sigma_u = 700$  MPa = 700 N/mm<sup>2</sup> ;  $\sigma_y = 500$  MPa = 500 N/mm<sup>2</sup> ;  $\sigma_e = 330$  MPa = 330 N/mm<sup>2</sup> ;  $F.S. = 1.3$  ;  $K_{sz} = 0.85$  ;  $K_{sur} = 0.9$

We know that maximum bending moment,

$$M_{max} = \frac{W_{max} \times L}{4} = \frac{4P \times 500}{4} = 500P \text{ N-mm}$$

and minimum bending moment,

$$M_{min} = \frac{W_{min} \times L}{4} = \frac{P \times 500}{4} = 125P \text{ N mm}$$

∴ Mean or average bending moment,

$$M_m = \frac{M_{max} + M_{min}}{2} = \frac{500P + 125P}{2} = 312.5P \text{ N-mm}$$

and variable bending moment,

$$M_v = \frac{M_{max} - M_{min}}{2} = \frac{500P - 125P}{2} = 187.5P \text{ N-mm}$$

Section modulus,

$$Z = \frac{\pi}{32} \times d^3 = \frac{\pi}{32} (60)^3 = 21.21 \times 10^3 \text{ mm}^3$$

∴ Mean bending stress,

$$\sigma_m = \frac{M_m}{Z} = \frac{312.5P}{21.21 \times 10^3} = 0.0147P \text{ N/mm}^2$$

and variable bending stress,

$$\sigma_v = \frac{M_v}{Z} = \frac{187.5P}{21.21 \times 10^3} = 0.0088P \text{ N/mm}^2$$

We know that according to Goodman's formula,

$$\begin{aligned} \frac{1}{F.S.} &= \frac{\sigma_m}{\sigma_u} + \frac{\sigma_v \times K_f}{\sigma_e \times K_{sur} \times K_{sz}} \\ \frac{1}{1.3} &= \frac{0.0147P}{700} + \frac{0.0088P \times 1}{330 \times 0.9 \times 0.85} \quad \dots(\text{Taking } K_f = 1) \\ &= \frac{21P}{10^6} + \frac{34.8P}{10^6} = \frac{55.8P}{10^6} \\ \therefore P &= \frac{1}{1.3} \times \frac{10^6}{55.8} = 13\,785 \text{ N} = 13.785 \text{ kN} \end{aligned}$$

and according to Soderberg's formula,

$$\frac{1}{F.S.} = \frac{\sigma_m}{\sigma_y} + \frac{\sigma_v \times K_f}{\sigma_e \times K_{sur} \times K_{sz}}$$

$$\frac{1}{1.3} = \frac{0.0147P}{500} + \frac{0.0088P \times 1}{330 \times 0.9 \times 0.85} = \frac{29.4P}{10^6} + \frac{34.8P}{10^6} = \frac{64.2P}{10^6}$$

$$\therefore P = \frac{1}{1.3} \times \frac{10^6}{64.2} = 11982 \text{ N} = 11.982 \text{ kN}$$

From the above, we find that maximum value of  $P = 13.785 \text{ kN}$  Ans.

### References:

1. Machine Design - V.Bandari .
2. Machine Design – R.S. Khurmi
3. Design Data hand Book - S MD Jalaludin.



### Introduction to Riveted Joints

A rivet is a short cylindrical bar with a head integral to it. The cylindrical portion of the rivet is called **shank** or **body** and lower portion of shank is known as **tail**, as shown in Fig. The rivets are used to make permanent fastening between the plates such as in structural work, ship building, bridges, tanks and boiler shells. The riveted joints are widely used for joining light metals.

The fastenings (i.e. joints) may be classified into the following two groups:

1. Permanent fastenings, and
2. Temporary or detachable fastenings.

The fastenings (i.e. joints) may be classified into the following two groups:

1. Permanent fastenings, and
2. Temporary or detachable fastenings

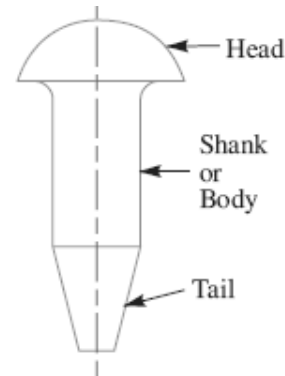

**Fig.** Rivet parts.

The **permanent fastenings** are those fastenings which cannot be disassembled without destroying the connecting components. The examples of permanent fastenings in order of strength are soldered, brazed, welded and riveted joints.

The **temporary** or **detachable fastenings** are those fastenings which can be disassembled without destroying the connecting components. The examples of temporary fastenings are screwed, keys, cotters, pins and splined joints.

### Methods of Riveting

The function of rivets in a joint is to make a connection that has strength and tightness. The strength is necessary to prevent failure of the joint. The tightness is necessary in order to contribute to strength and to prevent leakage as in a boiler or in a ship hull.

When two plates are to be fastened together by a rivet as shown in Fig. (a), the holes in the plates are punched and reamed or drilled. Punching is the cheapest method and is used for relatively thin plates and in structural work. Since punching injures the material around the hole, therefore drilling is used in most pressure-vessel work. In structural and pressure vessel riveting, the diameter of the rivet hole is usually 1.5 mm larger than the nominal diameter of the rivet.



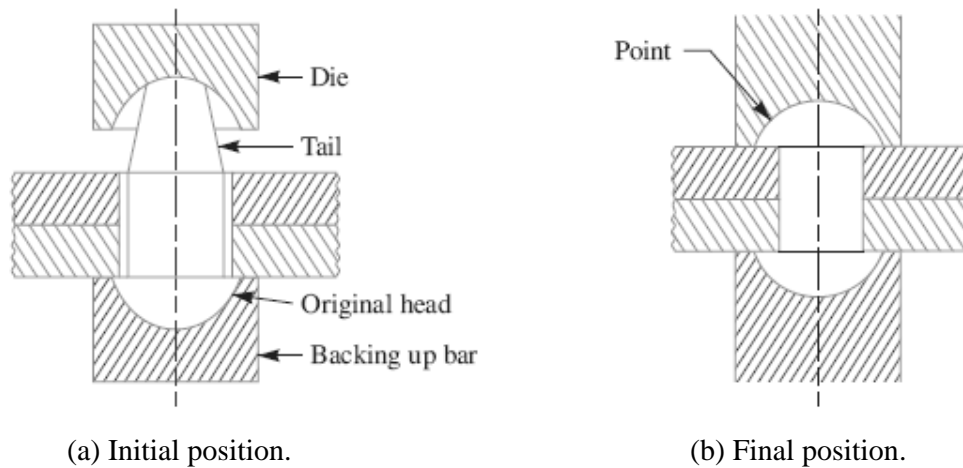

**Fig.** Methods of riveting.

The plates are drilled together and then separated to remove any burrs or chips so as to have a tight flush joint between the plates. A cold rivet or a red hot rivet is introduced into the plates and the **point** (i.e. second head) is then formed. When a cold rivet is used, the process is known as **cold riveting** and when a hot rivet is used, the process is known as **hot riveting**. The cold riveting process is used for structural joints while hot riveting is used to make leak proof joints.

The riveting may be done by hand or by a riveting machine. In hand riveting, the original rivet head is backed up by a hammer or heavy bar and then the die or set, as shown in Fig.(a), is placed against the end to be headed and the blows are applied by a hammer. This causes the shank to expand thus filling the hole and the tail is converted into a **point** as shown in Fig.(b). As the rivet cools, it tends to contract. The lateral contraction will be slight, but there will be a longitudinal tension introduced in the rivet which holds the plates firmly together.

In machine riveting, the die is a part of the hammer which is operated by air, hydraulic or steam pressure.

**Notes:**

1. For steel rivets up to 12 mm diameter, the cold riveting process may be used while for larger diameter rivets, hot riveting process is used.
2. In case of long rivets, only the tail is heated and not the whole shank.

**Types of Rivet Heads**

According to Indian standard specifications, the rivet heads are classified into the following three types:

1. Rivet heads for general purposes (below 12 mm diameter) as shown in Fig.

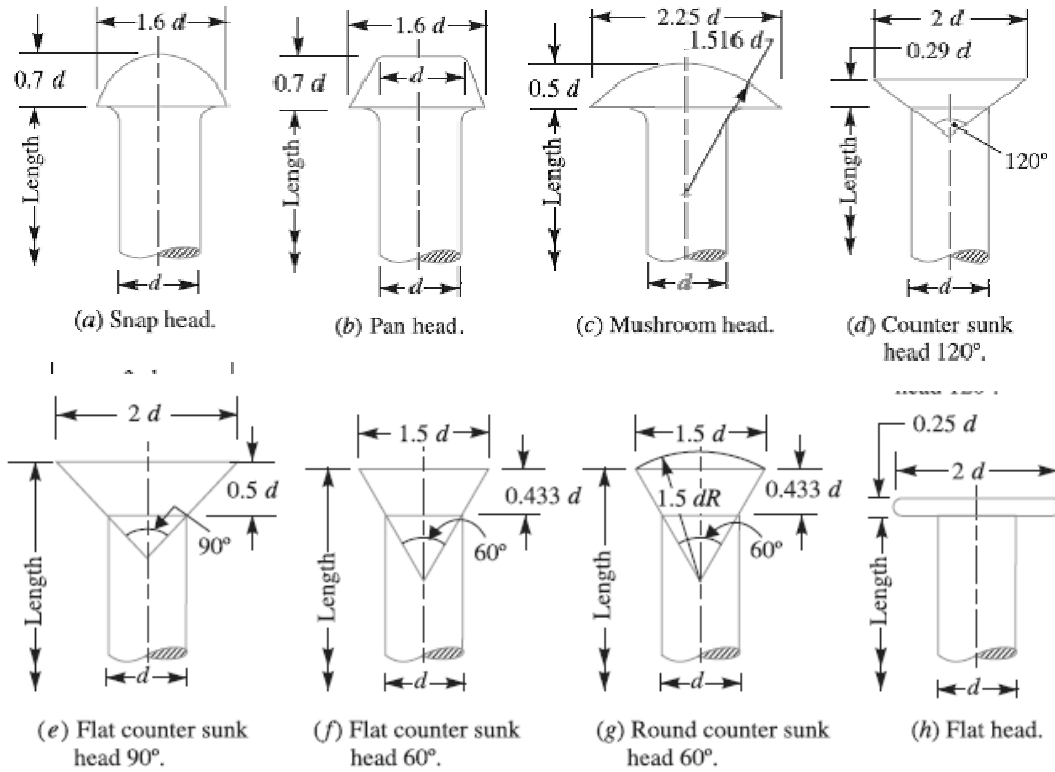
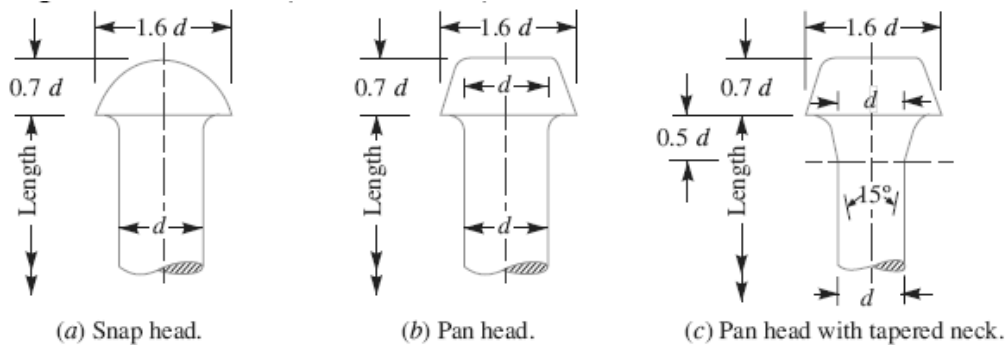

Fig. Rivet heads for general purposes (below 12 mm diameter).

2. Rivet heads for general purposes (From 12 mm to 48 mm diameter) as shown in Fig.



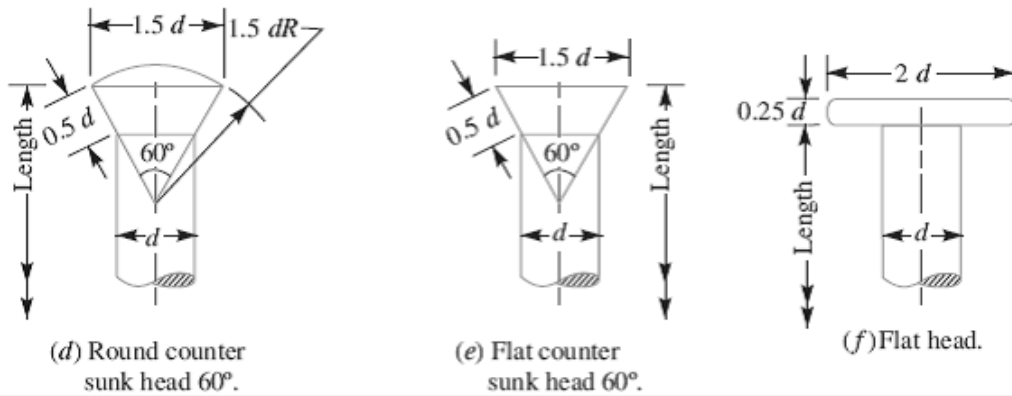
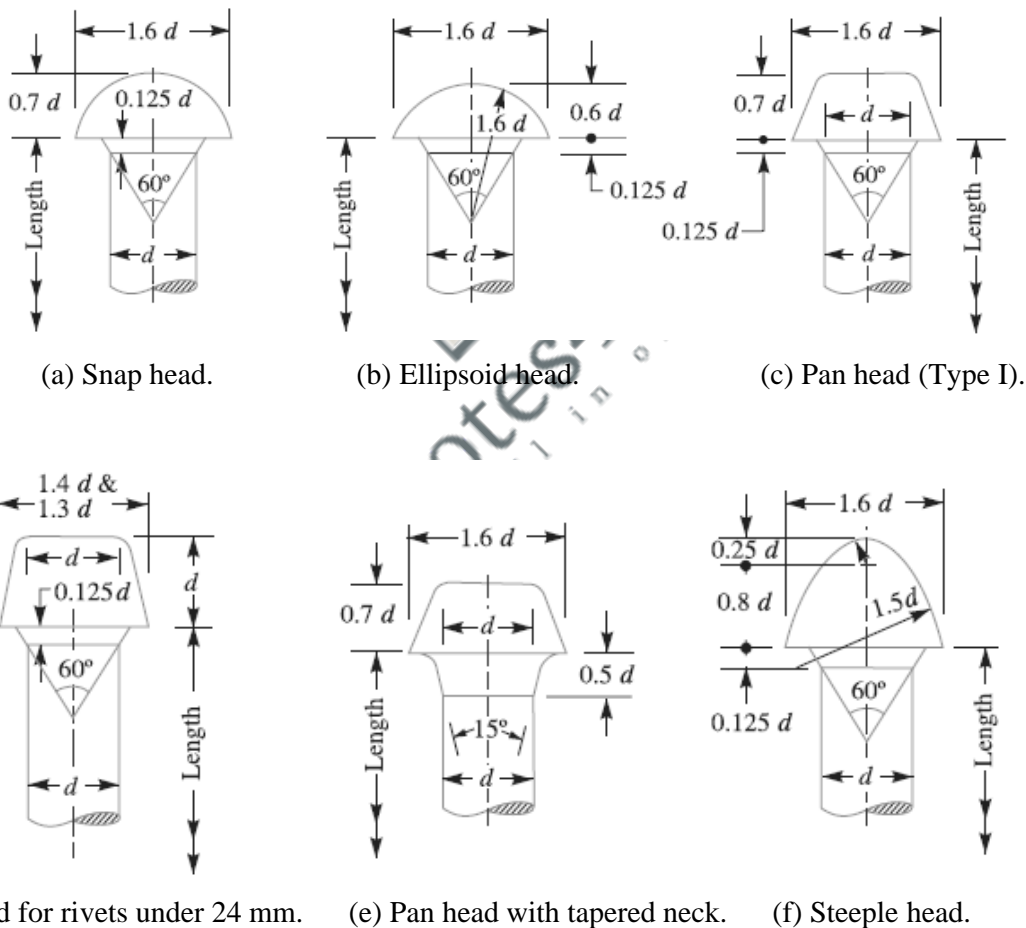

Fig. Rivet heads for general purposes (from 12 mm to 48 mm diameter)

3. Rivet heads for boiler work (from 12 mm to 48 mm diameter, as shown in Fig.)



**Types of Riveted Joints**

Following are the two types of riveted joints, depending upon the way in which the plates are connected.

1. Lap joint, and
2. Butt joint.

### 1. Lap Joint

A lap joint is that in which one plate overlaps the other and the two plates are then riveted together.

### 2. Butt Joint

A butt joint is that in which the main plates are kept in alignment butting (i.e. touching) each other and a cover plate (i.e. strap) is placed either on one side or on both sides of the main plates. The cover plate is then riveted together with the main plates. Butt joints are of the following two types:

1. Single strap butt joint, and
2. Double strap butt joint.

In a **single strap butt joint**, the edges of the main plates butt against each other and only one cover plate is placed on one side of the main plates and then riveted together. In a **double strap butt joint**, the edges of the main plates butt against each other and two cover plates are placed on both sides of the main plates and then riveted together.

In addition to the above, following are the types of riveted joints depending upon the number of rows of the rivets.

1. Single riveted joint, and
2. Double riveted joint.

A **single riveted joint** is that in which there is a single row of rivets in a lap joint as shown in Fig (a) and there is a single row of rivets on each side in a butt joint as shown in Fig. A **double riveted joint** is that in which there are two rows of rivets in a lap joint as shown in Fig. (b) and (c) and there are two rows of rivets on each side in a butt joint as shown in Fig.

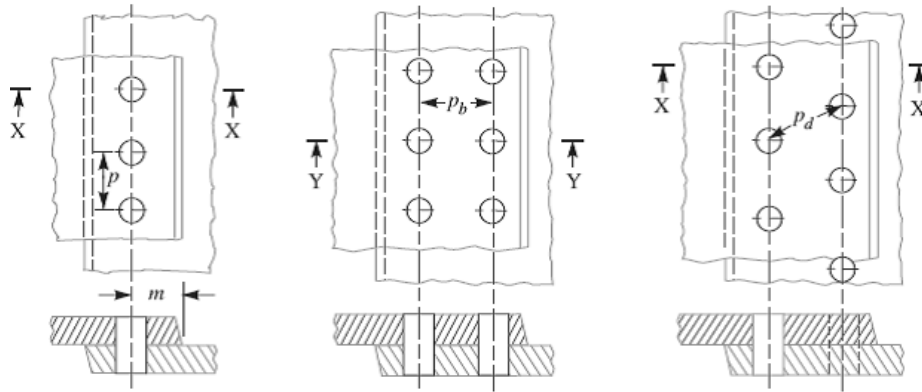

(a) Single riveted lap joint. (b) Double riveted lap joint (Chain riveting). (c) Double riveted lap joint (Zig-zag riveting).

Fig. Single and double riveted lap joints.

Similarly the joints may be **triple riveted** or **quadruple riveted**.

**Notes: 1.** when the rivets in the various rows are opposite to each other, as shown in Fig. (b), then the joint is said to be **chain riveted**. On the other hand, if the rivets in the adjacent rows are staggered in such a way that every rivet is in the middle of the two rivets of the opposite row as shown in Fig. (c), then the joint is said to be **zig-zag riveted**.

**2.** Since the plates overlap in lap joints, therefore the force P, P acting on the plates are not in the same straight line but they are at a distance equal to the thickness of the plate. These forces will form a couple which may bend the joint. Hence the lap joints may be used only where small loads are to be transmitted. On the other hand, the forces P, P in a butt joint act in the same straight line, therefore there will be no couple. Hence the butt joints are used where heavy loads are to be transmitted.

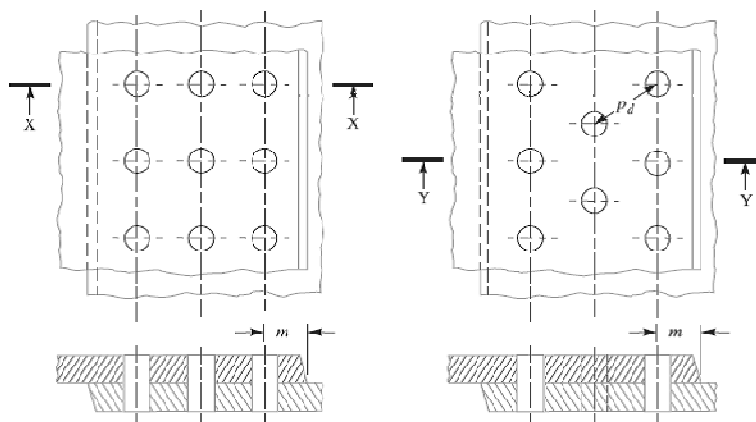

(a) Chain riveting. (b) Zig-zag riveting.

Fig. 9.7. Triple riveted lap joint.

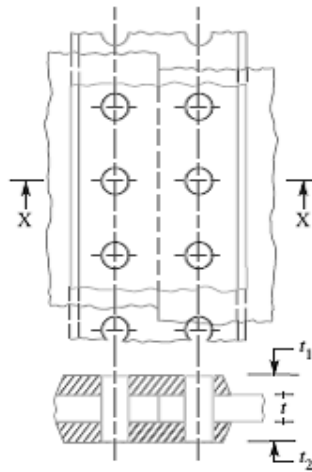
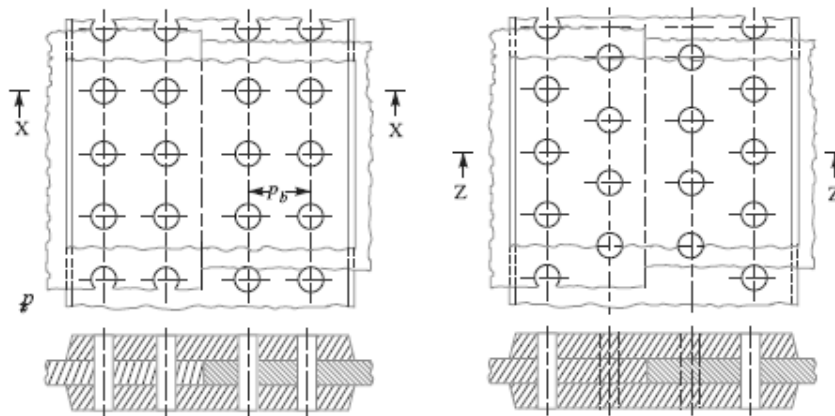

Fig. Single riveted double strap butt joint.



(a) Chain a riveting.

(b) Zig-zag riveting

Fig. Double riveted double strap (equal) butt joints.

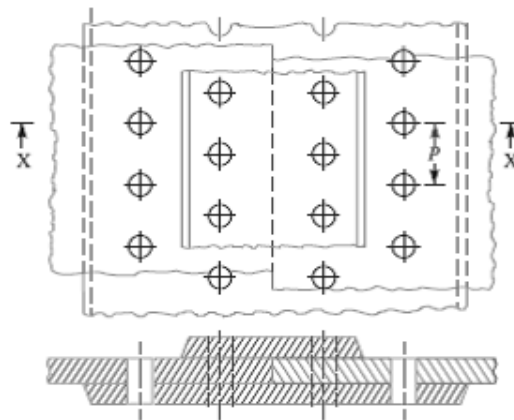

Fig. Double riveted double strap (unequal) butt joint with zig-zag riveting.

**References:**

1. Machine Design - V.Bandari .
2. Machine Design – R.S. Khurmi
3. Design Data hand Book - S MD Jalaludin.



**Important Terms Used in Riveted Joints**

The following terms in connection with the riveted joints are important from the subject point of view:

1. **Pitch.** It is the distance from the centre of one rivet to the centre of the next rivet measured parallel to the seam as shown in Fig.1 It is usually denoted by  $p$ .
2. **Back pitch.** It is the perpendicular distance between the centre lines of the successive rows as shown in Fig.1. It is usually denoted by  $p_b$ .
3. **Diagonal pitch.** It is the distance between the centers of the rivets in adjacent rows of zigzag riveted joint as shown in Fig. It is usually denoted by  $p_d$ .
4. **Margin or marginal pitch.** It is the distance between the centres of rivet hole to the nearest edge of the plate as shown in Fig. 9.6. It is usually denoted by  $m$ .

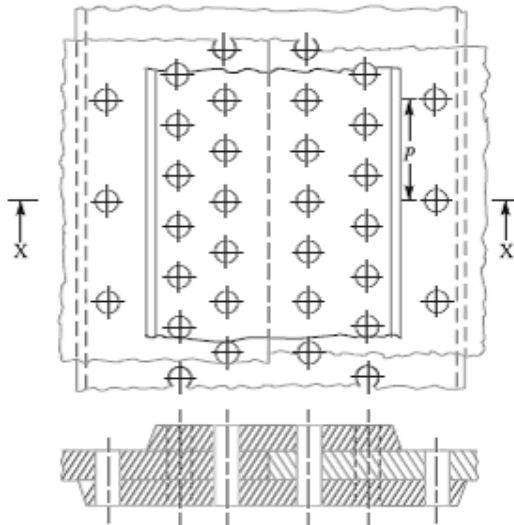

**Fig.1.** Triple riveted double strap (unequal) butt joint.

**Caulking and Fullering**

In order to make the joints leak proof or fluid tight in pressure vessels like steam boilers, air receivers and tanks etc. a process known as **caulking** is employed. In this process, a narrow blunt tool called caulking tool, about 5 mm thick and 38 mm in breadth, is used. The edge of the tool is ground to an angle of  $80^\circ$ . The tool is moved after each blow along the edge of the plate, which is planed to a level of  $75^\circ$  to  $80^\circ$  to facilitate the forcing down of edge. It is seen that the tool burrs down the plate at A in Fig.2 (a) forming a metal to metal joint. In actual practice, both the edges at A and B are caulked. The head of the rivets as shown at C are also



turned down with a caulking tool to make a joint steam tight. A great care is taken to prevent injury to the plate below the tool.

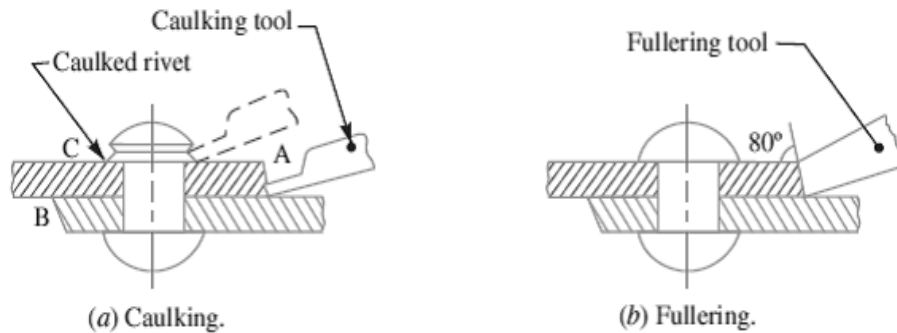

**Fig.2.** Caulking and fullering.

A more satisfactory way of making the joints staunch is known as **fullering** which has largely superseded caulking. In this case, a fullering tool with a thickness at the end equal to that of the plate is used in such a way that the greatest pressure due to the blows occur near the joint, giving a clean finish, with less risk of damaging the plate. A fullering process is shown in Fig. (b).

### Failures of a Riveted Joint

A riveted joint may fail in the following ways:

**1. Tearing of the plate at an edge.** A joint may fail due to tearing of the plate at an edge as shown in Fig.3. This can be avoided by keeping the margin,  $m = 1.5d$ , where  $d$  is the diameter of the rivet hole.

**2. Tearing of the plate across a row of rivets.** Due to the tensile stresses in the main plates, the main plate or cover plates may tear off across a row of rivets as shown in Fig. In such cases, we consider only one pitch length of the plate, since every rivet is responsible for that much length of the plate only.

The resistance offered by the plate against tearing is known as **tearing resistance** or **tearing strength** or **tearing value** of the plate.

Let  $p$  = Pitch of the rivets,

$d$  = Diameter of the rivet hole,

$t$  = Thickness of the plate, and

$\sigma_t$  = Permissible tensile stress for the plate material.

We know that tearing area per pitch length,

$$A_t = (p-d)t$$

∴ Tearing resistance or pull required to tear off the plate per pitch length,

$$P_t = A_t \cdot \sigma_t = (p - d) t \cdot \sigma_t$$

When the tearing resistance ( $P_t$ ) is greater than the applied load ( $P$ ) per pitch length, then this type of failure will not occur.

**3. Shearing of the rivets.** The plates which are connected by the rivets exert tensile stress on the rivets, and if the rivets are unable to resist the stress, they are sheared off as shown in Fig. 5.

It may be noted that the rivets are in single shear in a lap joint and in a single cover butt joint, as shown in Fig. But the rivets are in double shear in a double cover butt joint as shown in Fig. The resistance offered by a rivet to be sheared off is known as **shearing resistance** or **shearing strength** or **shearing value** of the rivet.

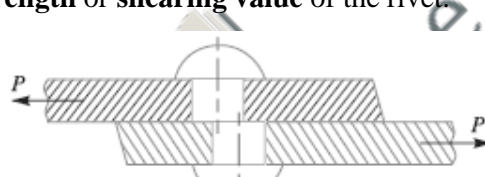

(a) Shearing off a rivet in a lap joint.

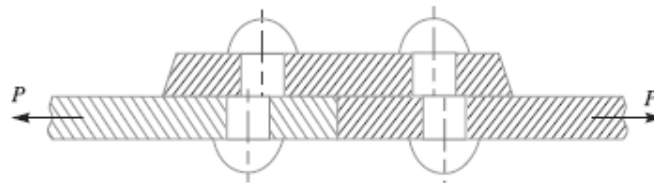

(b) Shearing off a rivet in a single cover butt joint.

**Fig. 5.** Shearing of rivets.

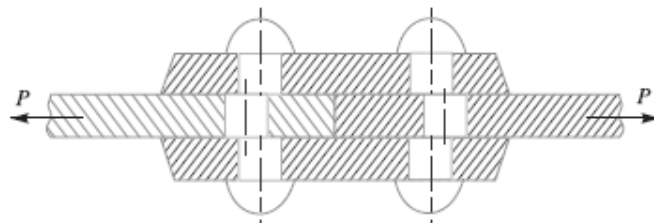

**Fig.6.** Shearing off a rivet in double cover butt joint.

Let  $d$  = Diameter of the rivet hole,

$\tau$  = Safe permissible shear stress for the rivet material, and

$n$  = Number of rivets per pitch length.

We know that shearing area,

$$A_s = \frac{\pi}{4} \times d^2 \quad \dots(\text{In single shear})$$

$$= 2 \times \frac{\pi}{4} \times d^2 \quad \dots (\text{Theoretically, in double shear})$$

$$= 1.875 \times \frac{\pi}{4} \times d^2 \quad \dots (\text{In double shear, according to Indian Boiler Regulations})$$

$\therefore$  Shearing resistance or pull required to shear off the rivet per pitch length,

$$P_s = n \times \frac{\pi}{4} \times d^2 \times \tau \quad \dots (\text{In single shear})$$

$$= n \times 2 \times \frac{\pi}{4} \times d^2 \times \tau \quad \dots (\text{Theoretically, in double shear})$$

As we discussed earlier, when the shearing takes place at one cross-section of the rivet, then the rivets are said to be in **single shear**. Similarly, when the shearing takes place at two cross-sections of the rivet, then the rivets are said to be in **double shear**.

$$= n \times 1.875 \times \frac{\pi}{4} \times d^2 \times \tau \quad \dots (\text{In double shear, according to Indian Boiler Regulations})$$

When the shearing resistance ( $P_s$ ) is greater than the applied load ( $P$ ) per pitch length, then this type of failure will occur.

**4. Crushing of the plate or rivets.** Sometimes, the rivets do not actually shear off under the tensile stress, but are crushed as shown in Fig. Due to this, the rivet hole becomes of an oval shape and hence the joint becomes loose. The failure of rivets in such a manner is also known as **bearing failure**. The area which resists this action is the projected area of the hole or rivet on diametric plane.

The resistance offered by a rivet to be crushed is known as **crushing resistance** or **crushing strength** or **bearing value** of the rivet.

Let  $d$  = Diameter of the rivet hole,

$t$  = Thickness of the plate,

$\sigma_c$  = Safe permissible crushing stress for the rivet or plate material, and

$n$  = Number of rivets per pitch length under crushing.

We know that crushing area per rivet (i.e. projected area per rivet),

$$A_c = d \cdot t$$

$\therefore$  Total crushing area =  $n \cdot d \cdot t$

And crushing resistance or pull required to crush the rivet per pitch length,

$$P_c = n \cdot d \cdot t \cdot \sigma_c$$

When the crushing resistance ( $P_c$ ) is greater than the applied load ( $P$ ) per pitch length, then this type of failure will occur.

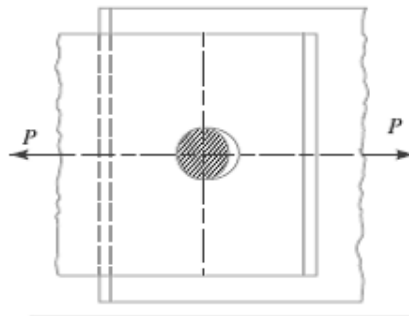

**Fig. 7.** Crushing of a rivet.

### Strength of a Riveted Joint

The strength of a joint may be defined as the maximum force, which it can transmit, without causing it to fail. We have seen that  $P_t$ ,  $P_s$  and  $P_c$  are the pulls required to tear off the plate, shearing off the rivet and crushing off the rivet. A little consideration will show that if we go on increasing the pull on a riveted joint, it will fail when the least of these three pulls is reached, because a higher value of the other pulls will never reach since the joint has failed, either by tearing off the plate, shearing off the rivet or crushing off the rivet.

If the joint is **continuous** as in case of boilers, the strength is calculated **per pitch length**. But if the joint is **small**, the strength is calculated for the **whole length** of the plate.

### Efficiency of a Riveted Joint

The efficiency of a riveted joint is defined as the ratio of the strength of riveted joint to the strength of the un-riveted or solid plate. We have already discussed that strength of the riveted joint

$$= \text{Least of } P_t, P_s \text{ and } P_c$$

Strength of the un-riveted or solid plate per pitch length,

$$P = p \cdot t \cdot \sigma_t$$

∴ Efficiency of the riveted joint,

$$\eta = \frac{\text{Least of } P_t, P_s \text{ and } P_c}{p \times t \times \sigma_t}$$

Where  $p$  = Pitch of the rivets,

$t$  = Thickness of the plate, and

$\sigma_t$  = Permissible tensile stress of the plate material.

**References:**

1. Machine Design - V.Bandari .
2. Machine Design – R.S. Khurmi
3. Design Data hand Book - S MD Jalaludin.



Problems on design of riveted joints

Problem:

A double riveted lap joint is made between 15 mm thick plates. The rivet diameter and pitch are 25 mm and 75 mm respectively. If the ultimate stresses are 400 MPa in tension, 320 MPa in shear and 640 MPa in crushing, find the minimum force per pitch which will rupture the joint. If the above joint is subjected to a load such that the factor of safety is 4, find out the actual stresses developed in the plates and the rivets.

**Solution.** Given :  $t = 15 \text{ mm}$  ;  $d = 25 \text{ mm}$  ;  $p = 75 \text{ mm}$  ;  $\sigma_{tu} = 400 \text{ MPa} = 400 \text{ N/mm}^2$  ;  $\tau_u = 320 \text{ MPa} = 320 \text{ N/mm}^2$  ;  $\sigma_{cu} = 640 \text{ MPa} = 640 \text{ N/mm}^2$

*Minimum force per pitch which will rupture the joint*

Since the ultimate stresses are given, therefore we shall find the ultimate values of the resistances of the joint. We know that ultimate tearing resistance of the plate per pitch,

$$P_{tu} = (p - d)t \times \sigma_{tu} = (75 - 25)15 \times 400 = 300\,000 \text{ N}$$

Ultimate shearing resistance of the rivets per pitch,

$$P_{su} = n \times \frac{\pi}{4} \times d^2 \times \tau_u = 2 \times \frac{\pi}{4} (25)^2 320 = 314\,200 \text{ N} \quad \dots (\because n = 2)$$

and ultimate crushing resistance of the rivets per pitch,

$$P_{cu} = n \times d \times t \times \sigma_{cu} = 2 \times 25 \times 15 \times 640 = 480\,000 \text{ N}$$

From above we see that the minimum force per pitch which will rupture the joint is 300 000 N or 300 kN. **Ans.**

*Actual stresses produced in the plates and rivets*

Since the factor of safety is 4, therefore safe load per pitch length of the joint  
 $= 300\,000 / 4 = 75\,000 \text{ N}$

Let  $\sigma_{ta}$ ,  $\tau_a$  and  $\sigma_{ca}$  be the actual tearing, shearing and crushing stresses produced with a safe load of 75 000 N in tearing, shearing and crushing.

We know that actual tearing resistance of the plates ( $P_{ta}$ ),

$$75\,000 = (p - d)t \times \sigma_{ta} = (75 - 25)15 \times \sigma_{ta} = 750 \sigma_{ta}$$

$$\therefore \sigma_{ta} = 75\,000 / 750 = 100 \text{ N/mm}^2 = 100 \text{ MPa} \quad \text{Ans.}$$

Actual shearing resistance of the rivets ( $P_{sa}$ ),

$$75\,000 = n \times \frac{\pi}{4} \times d^2 \times \tau_a = 2 \times \frac{\pi}{4} (25)^2 \tau_a = 982 \tau_a$$

$$\therefore \tau_a = 75000 / 982 = 76.4 \text{ N/mm}^2 = 76.4 \text{ MPa} \quad \text{Ans.}$$

and actual crushing resistance of the rivets ( $P_{ca}$ ),

$$75\,000 = n \times d \times t \times \sigma_{ca} = 2 \times 25 \times 15 \times \sigma_{ca} = 750 \sigma_{ca}$$

$$\therefore \sigma_{ca} = 75000 / 750 = 100 \text{ N/mm}^2 = 100 \text{ MPa} \quad \text{Ans.}$$

Problem

Find the efficiency of the following riveted joints:

1. Single riveted lap joint of 6 mm plates with 20 mm diameter rivets having a pitch of 50 mm.
  2. Double riveted lap joint of 6 mm plates with 20 mm diameter rivets having a pitch of 65 mm.
- Assume Permissible tensile stress in plate = 120 MPa Permissible shearing stress in rivets = 90 MPa Permissible crushing stress in rivets = 180 MPa.

**Solution.** Given :  $t = 6 \text{ mm}$  ;  $d = 20 \text{ mm}$  ;  $\sigma_t = 120 \text{ MPa} = 120 \text{ N/mm}^2$  ;  $\tau = 90 \text{ MPa} = 90 \text{ N/mm}^2$  ;  $\sigma_c = 180 \text{ MPa} = 180 \text{ N/mm}^2$

**1. Efficiency of the first joint**

Pitch,  $p = 50 \text{ mm}$  ... (Given)

First of all, let us find the tearing resistance of the plate, shearing and crushing resistances of the rivets.

**(i) Tearing resistance of the plate**

We know that the tearing resistance of the plate per pitch length,

$$P_t = (p - d) t \times \sigma_t = (50 - 20) 6 \times 120 = 21\,600 \text{ N}$$

**(ii) Shearing resistance of the rivet**

Since the joint is a single riveted lap joint, therefore the strength of one rivet in single shear is taken. We know that shearing resistance of one rivet,

$$P_s = \frac{\pi}{4} \times d^2 \times \tau = \frac{\pi}{4} (20)^2 90 = 28\,278 \text{ N}$$

**(iii) Crushing resistance of the rivet**

Since the joint is a single riveted, therefore strength of one rivet is taken. We know that crushing resistance of one rivet,

$$P_c = d \times t \times \sigma_c = 20 \times 6 \times 180 = 21\,600 \text{ N}$$

$\therefore$  Strength of the joint

$$= \text{Least of } P_t, P_s \text{ and } P_c = 21\,600 \text{ N}$$

We know that strength of the unriveted or solid plate,

$$P = p \times t \times \sigma_t = 50 \times 6 \times 120 = 36\,000 \text{ N}$$

$\therefore$  Efficiency of the joint,

$$\eta = \frac{\text{Least of } P_t, P_s \text{ and } P_c}{P} = \frac{21\,600}{36\,000} = 0.60 \text{ or } 60\% \text{ Ans.}$$

**2. Efficiency of the second joint**

Pitch,  $p = 65 \text{ mm}$  ... (Given)

**(i) Tearing resistance of the plate,**

We know that the tearing resistance of the plate per pitch length,

$$P_t = (p - d) t \times \sigma_t = (65 - 20) 6 \times 120 = 32\,400 \text{ N}$$

*(ii) Shearing resistance of the rivets*

Since the joint is double riveted lap joint, therefore strength of two rivets in single shear is taken. We know that shearing resistance of the rivets,

$$P_s = n \times \frac{\pi}{4} \times d^2 \times \tau = 2 \times \frac{\pi}{4} (20)^2 90 = 56\,556 \text{ N}$$

*(iii) Crushing resistance of the rivet*

Since the joint is double riveted, therefore strength of two rivets is taken. We know that crushing resistance of rivets,

$$P_c = n \times d \times t \times \sigma_c = 2 \times 20 \times 6 \times 180 = 43\,200 \text{ N}$$

∴ Strength of the joint

$$= \text{Least of } P_t, P_s \text{ and } P_c = 32\,400 \text{ N}$$

We know that the strength of the unriveted or solid plate,

$$P = p \times t \times \sigma_t = 65 \times 6 \times 120 = 46\,800 \text{ N}$$

∴ Efficiency of the joint,

$$\eta = \frac{\text{Least of } P_t, P_s \text{ and } P_c}{P} = \frac{32\,400}{46\,800} = 0.692 \text{ or } 69.2\% \quad \text{Ans.}$$

**References:**

1. Machine Design - V.Bandari.
2. Machine Design – R.S. Khurmi
3. Design Data hand Book - S MD Jalaludin.





Design of boiler joints according to IBR

### Design of Boiler Joints

The boiler has a longitudinal joint as well as circumferential joint. The *longitudinal joint* is used to join the ends of the plate to get the required diameter of a boiler. For this purpose, a butt joint with two cover plates is used. The *circumferential joint* is used to get the required length of the boiler. For this purpose, a lap joint with one ring overlapping the other alternately is used.

Since a boiler is made up of number of rings, therefore the longitudinal joints are staggered for convenience of connecting rings at places where both longitudinal and circumferential joints occur.

### Design of Longitudinal Butt Joint for a Boiler

According to Indian Boiler Regulations (I.B.R), the following procedure should be adopted for the design of longitudinal butt joint for a boiler.

**1. Thickness of boiler shell.** First of all, the thickness of the boiler shell is determined by using the thin cylindrical formula, *i.e.*

$$t = \frac{P.D}{2 \sigma_t \times \eta_l} + 1 \text{ mm as corrosion allowance}$$

Where  $t$  = Thickness of the boiler shell,

$P$  = Steam pressure in boiler,

$D$  = Internal diameter of boiler shell,

$\sigma_t$  = Permissible tensile stress, and

$\eta_l$  = Efficiency of the longitudinal joint.

The following points may be noted:

- (a) The thickness of the boiler shell should not be less than 7 mm.
- (b) The efficiency of the joint may be taken from the following table.

Indian Boiler Regulations (I.B.R.) allows a maximum efficiency of 85% for the best joint.

- (c) According to I.B.R., the factor of safety should not be less than 4.

**2. Diameter of rivets.** After finding out the thickness of the boiler shell ( $t$ ), the diameter of the rivet hole ( $d$ ) may be determined by using Unwin's empirical formula,

*i.e.*  $d = 6 t$  (when  $t$  is greater than 8 mm)

But if the thickness of plate is less than 8 mm, then the diameter of the rivet hole may be calculated by equating the shearing resistance of the rivets to crushing resistance. In no case,

the diameter of rivet hole should not be less than the thickness of the plate, because there will be danger of punch crushing.

**3. Pitch of rivets.** The pitch of the rivets is obtained by equating the tearing resistance of the plate to the shearing resistance of the rivets. It may be noted that (a) The pitch of the rivets should not be less than  $2d$ , which is necessary for the formation of head.

(b) The maximum value of the pitch of rivets for a longitudinal joint of a boiler as per I.B.R. is  $p_{max} = C \times t + 41.28$  mm where  $t$  = Thickness of the shell plate in mm, and  $C$  = Constant. The value of the constant  $C$  may be taken from DDB. If the pitch of rivets as obtained by equating the tearing resistance to the shearing resistance is more than  $p_{max}$ , then the value of  $p_{max}$  is taken.

**4. Distance between the rows of rivets.** The distance between the rows of rivets as specified by Indian Boiler Regulations is as follows:

(a) For equal number of rivets in more than one row for lap joint or butt joint, the distance between the rows of rivets ( $p_b$ ) should not be less than  $0.33 p + 0.67 d$ , for zig-zig riveting, and  $2 d$ , for chain riveting.

(b) For joints in which the number of rivets in outer rows is *half* the number of rivets in inner rows and if the inner rows are chain riveted, the distance between the outer rows and the next rows should not be less than  $0.33 p + 0.67 d$  or  $2 d$ , whichever is greater. The distance between the rows in which there are full number of rivets shall not be less than  $2d$ .

(c) For joints in which the number of rivets in outer rows is *half* the number of rivets in inner rows and if the inner rows are zig-zig riveted, the distance between the outer rows and the next rows shall not be less than  $0.2 p + 1.15 d$ . The distance between the rows in which there are full number of rivets (zig-zag) shall not be less than  $0.165 p + 0.67 d$ .

**Note :** In the above discussion,  $p$  is the pitch of the rivets in the outer rows.

**5. Thickness of butt strap.** According to I.B.R., the thicknesses for butt strap ( $t_1$ ) are as given below:

(a) The thickness of butt strap, in no case, shall be less than 10 mm.

(b)  $t_1 = 1.125 t$ , for ordinary (chain riveting) single butt strap.

$$t_1 = 1.125 t \left( \frac{p - d}{p - 2d} \right)$$

For single butt straps, every alternate rivet in outer rows being omitted.

$t_1 = 0.625 t$ , for double butt-straps of equal width having ordinary riveting (chain riveting).

$$t_1 = 0.625 t \left( \frac{p - d}{p - 2d} \right)$$

For double butt straps of equal width having every alternate rivet in the outer rows being omitted.

(c) For unequal width of butt straps, the thicknesses of butt strap are

$t_1 = 0.75 t$ , for wide strap on the inside, and

$t_1 = 0.625 t$ , for narrow strap on the outside.

**6. Margin.** The margin ( $m$ ) is taken as  $1.5 d$ .

**Note:** The above procedure may also be applied to ordinary riveted joints.

**References:**

1. Machine Design - V.Bandari .
2. Machine Design – R.S. Khurmi
3. Design Data hand Book - S MD Jalaludin.



Design of eccentric loaded riveted joints and Problems

**Eccentric Loaded Riveted Joint**

When the line of action of the load does not pass through the centroid of the rivet system and thus all rivets are not equally loaded, then the joint is said to be an *eccentric loaded riveted joint*, as shown in Fig. 1(a). The eccentric loading results in secondary shear caused by the tendency of force to twist the joint about the centre of gravity in addition to direct shear or primary shear.

Let  $P =$  Eccentric load on the joint, and

$e =$  Eccentricity of the load *i.e.* the distance between the line of action of the load and the centroid of the rivet system *i.e.*  $G$ .

The following procedure is adopted for the design of an eccentrically loaded riveted joint.

Note: This picture is given as additional information and is not a direct example of the current chapter.

1. First of all, find the centre of gravity  $G$  of the rivet system.

Let  $A =$  Cross-sectional area of each rivet,

$x_1, x_2, x_3$  etc. = Distances of rivets from  $OY$ , and

$y_1, y_2, y_3$  etc. = Distances of rivets from  $OX$ .

We know that 
$$\bar{x} = \frac{A_1x_1 + A_2x_2 + A_3x_3 + \dots}{A_1 + A_2 + A_3 + \dots} = \frac{Ax_1 + Ax_2 + Ax_3 + \dots}{n.A}$$

$$= \frac{x_1 + x_2 + x_3 + \dots}{n} \quad \dots(\text{where } n = \text{Number of rivets})$$

Similarly, 
$$\bar{y} = \frac{y_1 + y_2 + y_3 + \dots}{n}$$

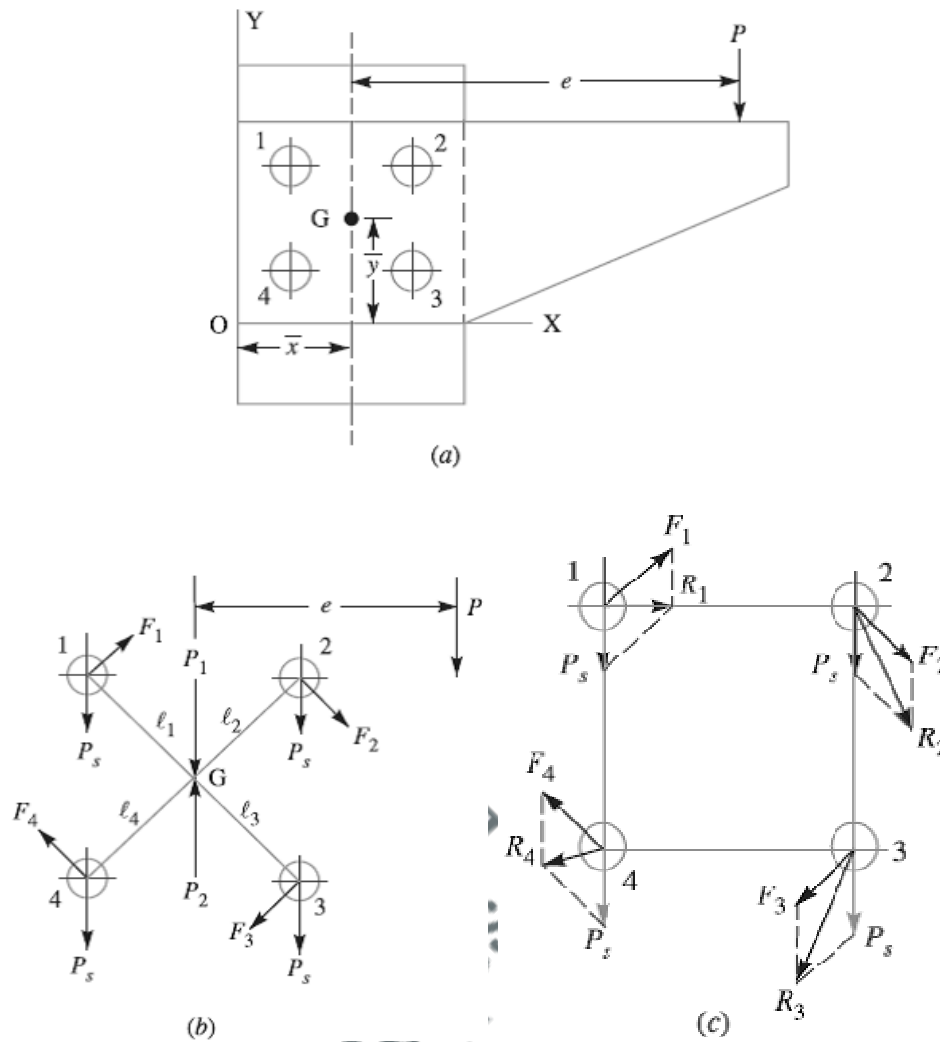

Fig. 1. Eccentric loaded riveted joint.

2. Introduce two forces  $P_1$  and  $P_2$  at the centre of gravity 'G' of the rivet system. These forces are equal and opposite to  $P$  as shown in Fig.(b).

3. Assuming that all the rivets are of the same size, the effect of  $P_1 = P$  is to produce direct shear load on each rivet of equal magnitude. Therefore, direct shear load on each rivet,

$$P_s = \frac{P}{n}, \text{ acting parallel to the load } P,$$

4. The effect of  $P_2 = P$  is to produce a turning moment of magnitude  $P \times e$  which tends to rotate the joint about the centre of gravity 'G' of the rivet system in a clockwise direction. Due to the turning moment, secondary shear load on each rivet is produced. In order to find the secondary shear load, the following two assumptions are made:

(a) The secondary shear load is proportional to the radial distance of the rivet under consideration from the centre of gravity of the rivet system.

(b) The direction of secondary shear load is perpendicular to the line joining the centre of the rivet to the centre of gravity of the rivet system..

Let  $F_1, F_2, F_3 \dots$  = Secondary shear loads on the rivets 1, 2, 3...etc.

$l_1, l_2, l_3 \dots$  = Radial distance of the rivets 1, 2, 3 ...etc. from the centre of gravity 'G' of the rivet system.

$\therefore$  From assumption (a),  $F_1 \propto l_1 ; F_2 \propto l_2$  and so on

or 
$$\frac{F_1}{l_1} = \frac{F_2}{l_2} = \frac{F_3}{l_3} = \dots$$

$$F_2 = F_1 \times \frac{l_2}{l_1}, \text{ and } F_3 = F_1 \times \frac{l_3}{l_1}$$

We know that the sum of the external turning moment due to the eccentric load and of internal resisting moment of the rivets must be equal to zero.

$$\begin{aligned} \therefore P.e &= F_1.l_1 + F_2.l_2 + F_3.l_3 + \dots \\ &= F_1.l_1 + F_1 \times \frac{l_2}{l_1} \times l_2 + F_1 \times \frac{l_3}{l_1} \times l_3 + \dots \\ &= \frac{F_1}{l_1} [(l_1)^2 + (l_2)^2 + (l_3)^2 + \dots] \end{aligned}$$

From the above expression, the value of  $F_1$  may be calculated and hence  $F_2$  and  $F_3$  etc. are known. The direction of these forces are at right angles to the lines joining the centre of rivet to the centre of gravity of the rivet system, as shown in Fig. 1(b), and should produce the moment in the same direction (*i.e.* clockwise or anticlockwise) about the centre of gravity, as the turning moment ( $P \times e$ ).

5. The primary (or direct) and secondary shear load may be added vectorially to determine the resultant shear load ( $R$ ) on each rivet as shown in Fig.1 (c). It may also be obtained by using the relation

$$R = \sqrt{(P_s)^2 + F_2 + 2P_s \times F \times \cos \theta}$$

Where  $\theta$  = Angle between the primary or direct shear load ( $P_s$ )

And secondary shear load ( $F$ ).

When the secondary shear load on each rivet is equal, then the heavily loaded rivet will be one in which the included angle between the direct shear load and secondary shear load is minimum. The maximum loaded rivet becomes the critical one for determining the strength of the riveted joint. Knowing the permissible shear stress ( $\tau$ ), the diameter of the rivet hole may be obtained by using the relation,

$$\text{Maximum resultant shear load (R)} = \frac{\pi}{4} \times d^2 \times \tau$$

From DDB, the standard diameter of the rivet hole ( $d$ ) and the rivet diameter may be specified

**Notes :** 1. In the solution of a problem, the primary and shear loads may be laid off approximately to scale and generally the rivet having the maximum resultant shear load will be apparent by inspection. The values of the load for that rivet may then be calculated.

2. When the thickness of the plate is given, then the diameter of the rivet hole may be checked against crushing.

3. When the eccentric load  $P$  is inclined at some angle, then the same procedure as discussed above may be followed to find the size of rivet.

**Problem:** An eccentrically loaded lap riveted joint is to be designed for a steel bracket as shown in Fig. 2. The bracket plate is 25 mm thick. All rivets are to be of the same size. Load on the bracket,  $P = 50$  kN ; rivet spacing,  $C = 100$  mm; load arm,  $e = 400$  mm. Permissible shear stress is 65 MPa and crushing stress is 120 MPa. Determine the size of the rivets to be used for the joint.

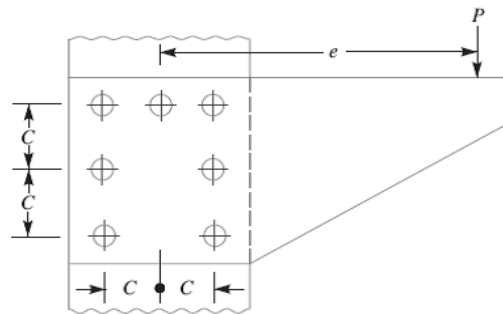

**Solution.** Given:  $t = 25 \text{ mm}$  ;  $P = 50 \text{ kN} = 50 \times 10^3 \text{ N}$  ;  $e = 400 \text{ mm}$  ;  $n = 7$  ;  $\tau = 65 \text{ MPa} = 65 \text{ N/mm}^2$  ;  $\sigma_c = 120 \text{ MPa} = 120 \text{ N/mm}^2$ .

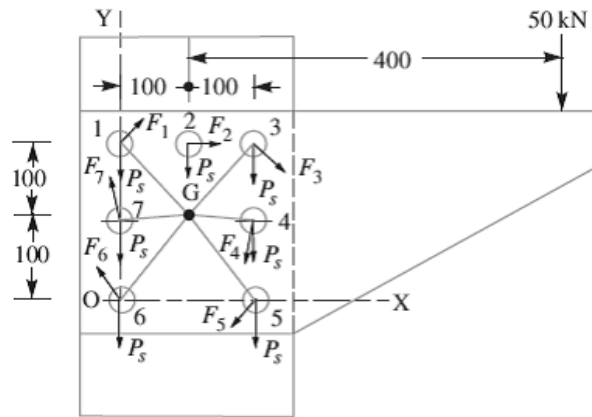

Fig.2

First of all, let us find the centre of gravity ( $G$ ) of the rivet system.

Let  $\bar{x}$  = Distance of centre of gravity from  $OY$ ,  
 $\bar{y}$  = Distance of centre of gravity from  $OX$ ,

$x_1, x_2, x_3, \dots$  = Distances of centre of gravity of each rivet from  $OY$ , and

$y_1, y_2, y_3, \dots$  = Distances of centre of gravity of each rivet from  $OX$ .

We know that

$$\begin{aligned} \bar{x} &= \frac{x_1 + x_2 + x_3 + x_4 + x_5 + x_6 + x_7}{n} \\ &= \frac{100 + 200 + 200 + 200}{7} = 100 \text{ mm} \quad \dots(\because x_1 = x_6 = x_7 = 0) \end{aligned}$$

$$\begin{aligned} \bar{y} &= \frac{y_1 + y_2 + y_3 + y_4 + y_5 + y_6 + y_7}{n} \\ &= \frac{200 + 200 + 200 + 100 + 100}{7} = 114.3 \text{ mm} \quad \dots(\because y_5 = y_6 = 0) \end{aligned}$$

The centre of gravity ( $G$ ) of the rivet system lies at a distance of 100 mm from  $OY$  and 114.3 mm from  $OX$ , as shown in Fig. 2.

We know that direct shear load on each rivet,



$$P_s = \frac{P}{n} = \frac{50 \times 10^3}{7} = 7143 \text{ N}$$

The direct shear load acts parallel to the direction of load  $P$  i.e. vertically downward as shown in Fig. 2. Turning moment produced by the load  $P$  due to eccentricity ( $e$ )

$$= P \times e = 50 \times 10^3 \times 400 = 20 \times 10^6 \text{ N-mm}$$

This turning moment is resisted by seven rivets as shown in Fig.2.

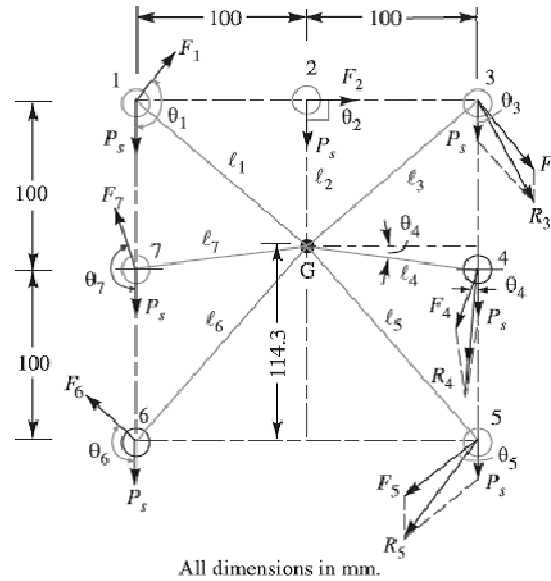

Fig. 3

Let  $F_1, F_2, F_3, F_4, F_5, F_6$  and  $F_7$  be the secondary shear load on the rivets 1, 2, 3, 4, 5, 6 and 7 placed at distances  $l_1, l_2, l_3, l_4, l_5, l_6$  and  $l_7$  respectively from the centre of gravity of the rivet system as shown in Fig. 3.

From the geometry of the figure, we find that

$$l_1 = l_3 = \sqrt{(100)^2 + (200 - 114.3)^2} = 131.7 \text{ mm}$$

$$l_2 = 200 - 114.3 = 85.7 \text{ mm}$$

$$l_4 = l_7 = \sqrt{(100)^2 + (114.3 - 100)^2} = 101 \text{ mm}$$

$$l_5 = l_6 = \sqrt{(100)^2 + (114.3)^2} = 152 \text{ mm}$$

Now equating the turning moment due to eccentricity of the load to the resisting moment of the rivets, we have

$$\begin{aligned}
 P \times e &= \frac{F_1}{l_1} \left[ (l_1)^2 + (l_2)^2 + (l_3)^2 + (l_4)^2 + (l_5)^2 + (l_6)^2 + (l_7)^2 \right] \\
 &= \frac{F_1}{l_1} \left[ 2(l_1)^2 + (l_2)^2 + 2(l_4)^2 + 2(l_5)^2 \right] \\
 &\quad \dots (\because l_1 = l_3; l_4 = l_7 \text{ and } l_5 = l_6)
 \end{aligned}$$

$$\begin{aligned}
 50 \times 10^3 \times 400 &= \frac{F_1}{131.7} \left[ 2(131.7)^2 + (85.7)^2 + 2(101)^2 + 2(152)^2 \right] \\
 20 \times 10^6 \times 131.7 &= F_1(34\,690 + 7345 + 20\,402 + 46\,208) = 108\,645 F_1 \\
 F_1 &= 20 \times 10^6 \times 131.7 / 108\,645 = 24\,244 \text{ N}
 \end{aligned}$$

Since the secondary shear loads are proportional to their radial distances from the centre of gravity, therefore

$$\begin{aligned}
 F_2 &= F_1 \times \frac{l_2}{l_1} = 24\,244 \times \frac{85.7}{131.7} = 15\,776 \text{ N} \\
 F_3 &= F_1 \times \frac{l_3}{l_1} = F_1 = 24\,244 \text{ N} \quad \dots (\because l_1 = l_3) \\
 F_4 &= F_1 \times \frac{l_4}{l_1} = 24\,244 \times \frac{101}{131.7} = 18\,593 \text{ N}
 \end{aligned}$$

By drawing the direct and secondary shear loads on each rivet, we see that the rivets 3, 4 and 5 are heavily loaded. Let us now find the angles between the direct and secondary shear load for these three rivets. From the geometry of Fig.3, we find that

$$\begin{aligned}
 \cos \theta_3 &= \frac{100}{l_3} = \frac{100}{131.7} = 0.76 \\
 \cos \theta_4 &= \frac{100}{l_4} = \frac{100}{101} = 0.99 \\
 \cos \theta_5 &= \frac{100}{l_5} = \frac{100}{152} = 0.658
 \end{aligned}$$

Now resultant shear load on rivet 3,

$$\begin{aligned}
 R_3 &= \sqrt{(P_s)^2 + (F_3)^2 + 2P_s \times F_3 \times \cos \theta_3} \\
 &= \sqrt{(7143)^2 + (24\,244)^2 + 2 \times 7143 \times 24\,244 \times 0.76} = 30\,033 \text{ N}
 \end{aligned}$$

Resultant shear load on rivet 4,

$$R_4 = \sqrt{(P_5)^2 + (F_4)^2 + 2 P_5 \times F_4 \times \cos \theta_4}$$

$$= \sqrt{(7143)^2 + (18\ 593)^2 + 2 \times 7143 \times 18\ 593 \times 0.99} = 25\ 684\ \text{N}$$

And resultant shear load on rivet 5,

$$R_5 = \sqrt{(P_5)^2 + (F_5)^2 + 2 P_5 \times F_5 \times \cos \theta_5}$$

$$= \sqrt{(7143)^2 + (27\ 981)^2 + 2 \times 7143 \times 27\ 981 \times 0.658} = 33\ 121\ \text{N}$$

The resultant shear load may be determined graphically, as shown in Fig.3.

From above we see that the maximum resultant shear load is on rivet 5. If  $d$  is the diameter of rivet hole, then maximum resultant shear load ( $R_5$ ),

$$33\ 121 = \frac{\pi}{4} \times d^2 \times \tau = \frac{\pi}{4} \times d^2 \times 65 = 51\ d^2$$

$$d^2 = 33\ 121 / 51 = 649.4 \quad \text{or} \quad d = 25.5\ \text{mm}$$

From DDB, we see that according the standard diameter of the rivet hole ( $d$ ) is 25.5 mm and the corresponding diameter of rivet is 24 mm.

Let us now check the joint for crushing stress. We know that

$$\text{Crushing stress} = \frac{\text{Max. load}}{\text{Crushing area}} = \frac{R_5}{d \times t} = \frac{33\ 121}{25.5 \times 25}$$

$$= 51.95\ \text{N/mm}^2 = 51.95\ \text{MPa}$$

Since this stress is well below the given crushing stress of 120 MPa, therefore the design is satisfactory.

#### **References:**

1. Machine Design - V.Bandari
2. Machine Design – R.S. Khurmi
3. Design Data hand Book - S MD Jalaludin.

## **Introduction to Welded Joints**

### **Introduction**

A welded joint is a permanent joint which is obtained by the fusion of the edges of the two parts to be joined together, with or without the application of pressure and a filler material. The heat required for the fusion of the material may be obtained by burning of gas (in case of gas welding) or by an electric arc (in case of electric arc welding). The latter method is extensively used because of greater speed of welding. Welding is extensively used in fabrication as an alternative method for casting or forging and as a replacement for bolted and riveted joints. It is also used as a repair medium *e.g.* to reunite metal at a crack, to build up a small part that has broken off such as gear tooth or to repair a worn surface such as a bearing surface.

### **Advantages and Disadvantages of Welded Joints over Riveted Joints**

Following are the advantages and disadvantages of welded joints over riveted joints.

#### ***Advantages***

1. The welded structures are usually lighter than riveted structures. This is due to the reason, that in welding, gussets or other connecting components are not used.
2. The welded joints provide maximum efficiency (may be 100%) which is not possible in case of riveted joints.
3. Alterations and additions can be easily made in the existing structures.
4. As the welded structure is smooth in appearance, therefore it looks pleasing.
5. In welded connections, the tension members are not weakened as in the case of riveted joints.
6. A welded joint has a great strength. Often a welded joint has the strength of the parent metal itself.
7. Sometimes, the members are of such a shape (*i.e.* circular steel pipes) that they afford difficulty for riveting. But they can be easily welded.
8. The welding provides very rigid joints. This is in line with the modern trend of providing rigid frames.
9. It is possible to weld any part of a structure at any point. But riveting requires enough clearance.
10. The process of welding takes less time than the riveting.

#### ***Disadvantages***

1. Since there is an uneven heating and cooling during fabrication, therefore the members may get distorted or additional stresses may develop.
2. It requires a highly skilled labour and supervision.
3. Since no provision is kept for expansion and contraction in the frame, therefore there is a possibility of cracks developing in it.
4. The inspection of welding work is more difficult than riveting work.

### Types of Welded Joints

Following two types of welded joints are important from the subject point of view:

1. Lap joint or fillet joint, and
2. Butt joint.

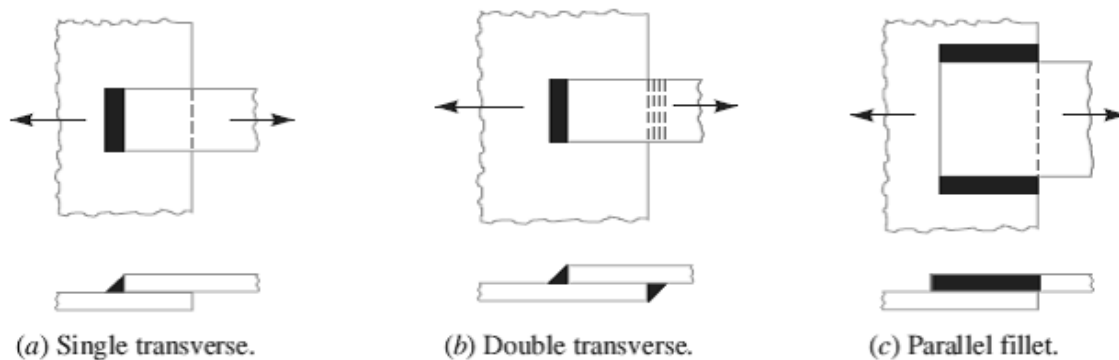

Fig.1. Types of Lap and Butt Joints

### Lap Joint

The lap joint or the fillet joint is obtained by overlapping the plates and then welding the edges of the plates. The cross-section of the fillet is approximately triangular. The fillet joints may be

1. Single transverse fillet,
2. Double transverse fillet and
3. Parallel fillet joints.

The fillet joints are shown in Fig.1. A single transverse fillet joint has the disadvantage that the edge of the plate which is not welded can buckle or warp out of shape.

### Butt Joint

The butt joint is obtained by placing the plates edge to edge as shown in Fig.2. In butt welds, the plate edges do not require beveling if the thickness of plate is less than 5 mm. On the other hand, if the plate thickness is 5 mm to 12.5 mm, the edges should be beveled to V or U-groove on both sides.

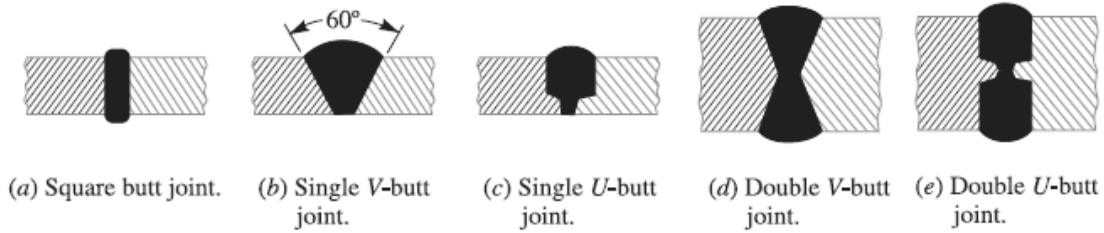

Fig. 2. Types of Butt joints

The butt joints may be

1. Square butt joint, 2. Single V-butt joint 3. Single U-butt joint,
4. Double V-butt joint, and 5. Double U-butt joint.

These joints are shown in Fig. 2.

The other type of welded joints are corner joint, edge joint and T-joint as shown in Fig. 3.

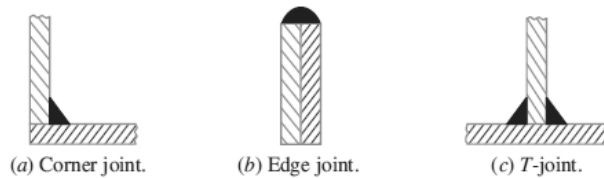



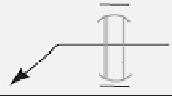

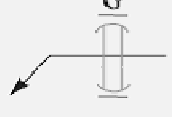

Fig. 3. Other types of Joints

Basic Weld Symbols

S. No.	Form of weld	Sectional representation	Symbol
1.	Fillet		
2.	Square butt		
3.	Single-V butt		
4.	Double-V butt		
5.	Single-U butt		
6.	Double-U butt		
7.	Single bevel butt		
8.	Double bevel butt		

S. No.	Form of weld	Sectional representation	Symbol
9.	Single-J butt		
10.	Double-J butt		
11.	Bead (edge or seal)		
12.	Stud		
13.	Sealing run		
14.	Spot		
15.	Seam		
16.	Mashed seam		
17.	Plug		
18.	Backing strip		
19.	Stitch		
20.	Projection		
21.	Flash		
22.	Butt resistance or pressure (upset)		

Supplementary Weld Symbols

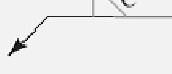
S. No.	Particulars	Drawing representation	Symbol
1.	Weld all round		○
2.	Field weld		●
3.	Flush contour		—
4.	Convex contour		⤴
5.	Concave contour		⤵
6.	Grinding finish		G
7.	Machining finish		M
8.	Chipping finish		C

**References:**

1. Machine Design - V.Bandari .
2. Machine Design – R.S. Khurmi
3. Design Data hand Book - S MD Jalaludin.



Elements of a welding symbol

**Elements of a Welding Symbol**

A welding symbol consists of the following eight elements:

1. Reference line,
2. Arrow,
3. Basic weld symbols,
4. Dimensions and other data,
5. Supplementary symbols,
6. Finish symbols,
7. Tail, and
8. Specification, process or other references.

**Standard Location of Elements of a Welding Symbol**

The arrow points to the location of weld, the basic symbols with dimensions are located on one or both sides of reference line. The specification if any is placed in the tail of arrow. Fig. 1. shows the standard locations of welding symbols represented on drawing.

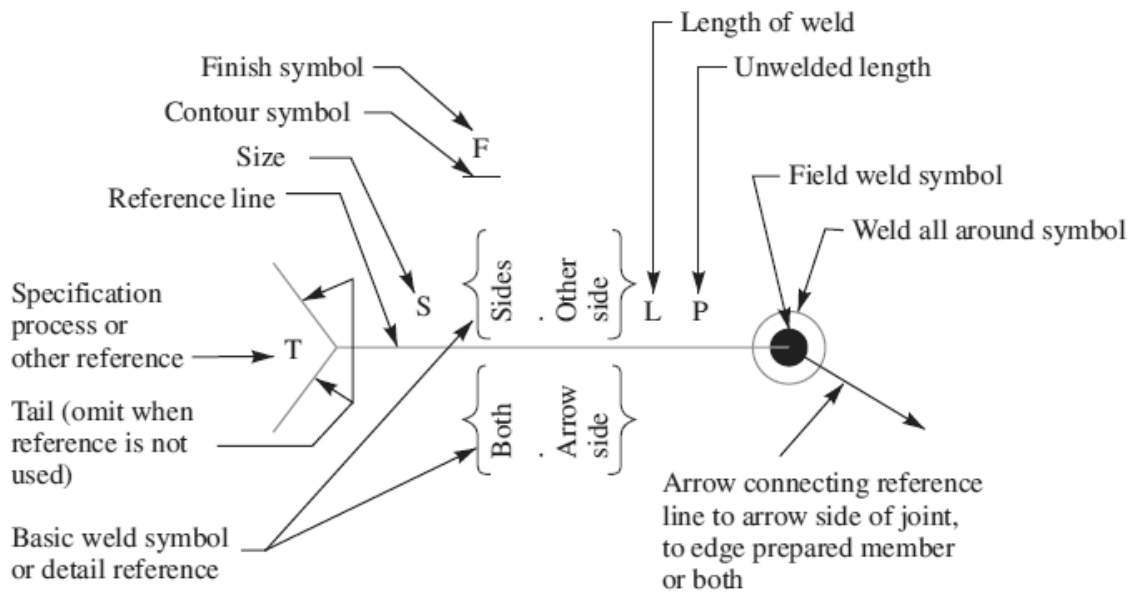

Fig.1 Standard location of weld symbols.

Some of the examples of welding symbols represented on drawing are shown in the following table.

**Representation of welding symbols.**

S. No.	Desired weld	Representation on drawing
1.	Fillet-weld each side of Tee- convex contour	
2.	Single V-butt weld -machining finish	
3.	Double V- butt weld	
4.	Plug weld - 30° Groove-angle-flush contour	
5.	Staggered intermittent fillet welds	

**References:**

1. Machine Design - V.Bandari .
2. Machine Design – R.S. Khurmi
3. Design Data hand Book - S MD Jalaludin.

Contents: Design of Welded Joints

**Strength of Transverse Fillet Welded Joints**

We have already discussed that the fillet or lap joint is obtained by overlapping the plates and then welding the edges of the plates. The transverse fillet welds are designed for tensile strength. Let us consider a single and double transverse fillet welds as shown in Fig. 1(a) and (b) respectively.

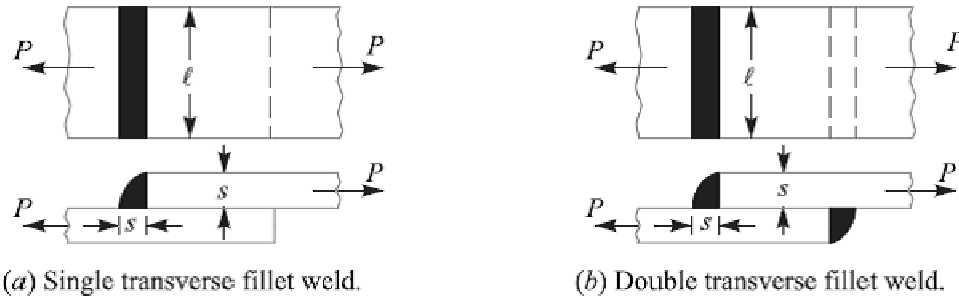

Fig.1 Transverse fillet welds.

The length of each side is known as **leg** or **size of the weld** and the perpendicular distance of the hypotenuse from the intersection of legs (*i.e.*  $BD$ ) is known as **throat thickness**. The minimum area of the weld is obtained at the throat  $BD$ , which is given by the product of the throat thickness and length of weld.

- Let  $t$  = Throat thickness ( $BD$ ),
- $s$  = Leg or size of weld,
- $t$  = Thickness of plate, and
- $l$  = Length of weld,

From Fig.2, we find that the throat thickness,

$$t = s \times \sin 45^\circ = 0.707 s$$

Therefore, Minimum area of the weld or throat area,

$$A = \text{Throat thickness} \times \text{Length of weld}$$

$$= t \times l = 0.707 s \times l$$

If  $\sigma_t$  is the allowable tensile stress for the weld metal, then the tensile strength of the joint for single fillet weld,

$$P = \text{Throat area} \times \text{Allowable tensile stress} = 0.707 s \times l \times \sigma_t$$

And tensile strength of the joint for double fillet weld,

$$P = 2 \times 0.707 s \times l \times \sigma_t = 1.414 s \times l \times \sigma_t$$

**Note:** Since the weld is weaker than the plate due to slag and blow holes, therefore the weld is given a reinforcement which may be taken as 10% of the plate thickness.

**Strength of Parallel Fillet Welded Joints**

The parallel fillet welded joints are designed for shear strength. Consider a double parallel fillet welded joint as shown in Fig.3 (a). We have already discussed in the previous article, that the minimum area of weld or the throat area,

$$A = 0.707 s \times l$$

If  $\tau$  is the allowable shear stress for the weld metal, then the shear strength of the joint for single parallel fillet weld,

$$P = \text{Throat area} \times \text{Allowable shear stress} = 0.707 s \times l \times \tau$$

And shear strength of the joint for double parallel fillet weld,

$$P = 2 \times 0.707 \times s \times l \times \tau = 1.414 s \times l \times \tau$$

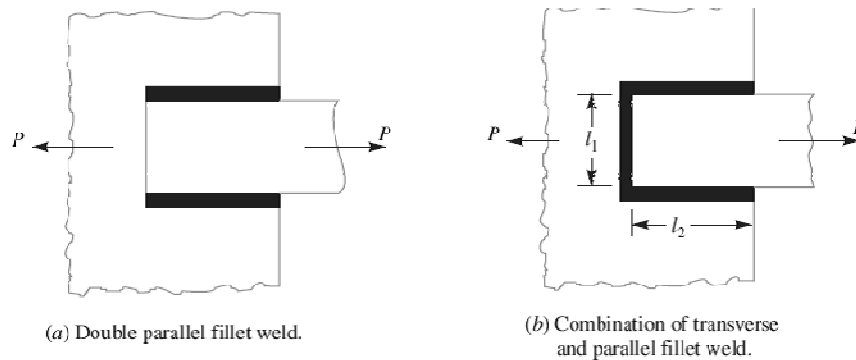

Fig.3

**Notes:** 1. If there is a combination of single transverse and double parallel fillet welds as shown in Fig. (b), then the strength of the joint is given by the sum of strengths of single transverse and double parallel fillet welds. Mathematically,

$$P = 0.707s \times l_1 \times \sigma_t + 1.414 s \times l_2 \times \tau$$

Where  $l_1$  is normally the width of the plate.

2. In order to allow for starting and stopping of the bead, 12.5 mm should be added to the length of each weld obtained by the above expression.

3. For reinforced fillet welds, the throat dimension may be taken as  $0.85 t$ .

Problem:

A plate 100 mm wide and 10 mm thick is to be welded to another plate by means of double parallel fillets. The plates are subjected to a static load of 80 kN. Find the length of weld if the permissible shear stress in the weld does not exceed 55 MPa.

**Solution. Given:** \*Width = 100 mm ;  
 Thickness = 10 mm ;  $P = 80 \text{ kN} = 80 \times 10^3 \text{ N}$  ;  
 $\tau = 55 \text{ MPa} = 55 \text{ N/mm}^2$

Let  $l$  = Length of weld, and

$s$  = Size of weld = Plate thickness = 10 mm  
 ... (Given)

We know that maximum load which the plates can carry for double parallel fillet weld ( $P$ ),

$$80 \times 10^3 = 1.414 \times s \times l \times \tau = 1.414 \times 10 \times l \times 55 = 778 l$$

$$\therefore l = 80 \times 10^3 / 778 = 103 \text{ mm}$$

Adding 12.5 mm for starting and stopping of weld run, we have

$$l = 103 + 12.5 = 115.5 \text{ mm Ans.}$$

### Strength of Butt Joints

The butt joints are designed for tension or compression. Consider a single V-butt joint as shown in Fig. 4(a).

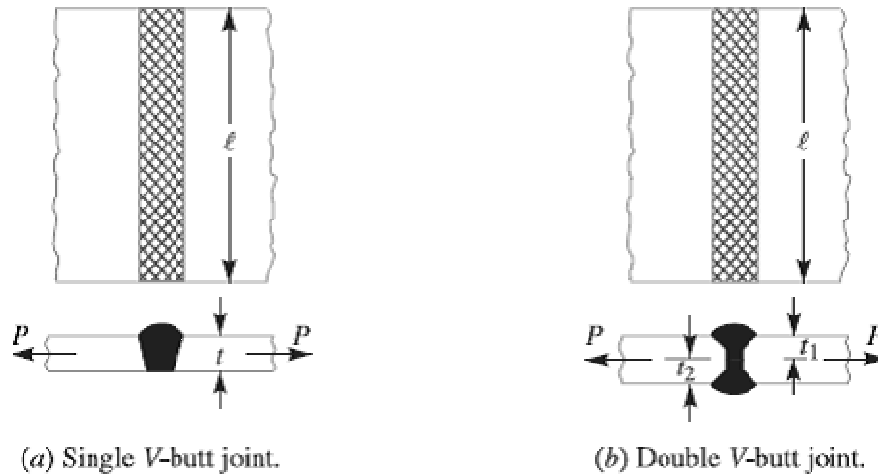

Fig.4. Butt Joints

In case of butt joint, the length of leg or size of weld is equal to the throat thickness which is equal to thickness of plates. Therefore, Tensile strength of the butt joint (single-V or square butt joint),

$$P = t \times l \times \sigma_t$$

Where  $l$  = Length of weld. It is generally equal to the width of plate. And tensile strength for double-V butt joint as shown in Fig. 4(b) is given by

$$P = (t_1 + t_2) l \times \sigma_t$$

Where  $t_1$  = Throat thickness at the top, and  
 $t_2$  = Throat thickness at the bottom.

It may be noted that size of the weld should be greater than the thickness of the plate, but it may be less. The following table shows recommended minimum size of the welds.

### **Stresses for Welded Joints**

The stresses in welded joints are difficult to determine because of the variable and unpredictable parameters like homogeneity of the weld metal, thermal stresses in the welds, changes of physical properties due to high rate of cooling etc. The stresses are obtained, on the following assumptions:

1. The load is distributed uniformly along the entire length of the weld, and
2. The stress is spread uniformly over its effective section.

The following table shows the stresses for welded joints for joining ferrous metals with mild steel electrode under steady and fatigue or reversed load.

### **Stress Concentration Factor for Welded Joints**

The reinforcement provided to the weld produces stress concentration at the junction of the weld and the parent metal. When the parts are subjected to fatigue loading, the stress concentration factors should be taken into account.

### **References:**

1. Machine Design - V. Bandari .
2. Machine Design – R.S. Khurmi
3. Design Data hand Book - S MD Jalaludin.



Problem:

A plate 100 mm wide and 12.5 mm thick is to be welded to another plate by means of parallel fillet welds. The plates are subjected to a load of 50 kN. Find the length of the weld so that the maximum stress does not exceed 56 MPa. Consider the joint first under static loading and then under fatigue loading.

**Solution. Given:** \*Width = 100 mm ; Thickness = 12.5 mm ;  $P = 50 \text{ kN} = 50 \times 10^3 \text{ N}$  ;  
 $\tau = 56 \text{ MPa} = 56 \text{ N/mm}^2$

*Length of weld for static loading*

Let  $l$  = Length of weld, and

$s$  = Size of weld = Plate thickness

= 12.5 mm ... (Given)

We know that the maximum load which the plates can carry for double parallel fillet welds ( $P$ ),

$$50 \times 10^3 = 1.414 s \times l \times \tau$$

$$= 1.414 \times 12.5 \times l \times 56 = 990 l$$

$$\therefore l = 50 \times 10^3 / 990 = 50.5 \text{ mm}$$

Adding 12.5 mm for starting and stopping of weld run, we have

$$l = 50.5 + 12.5 = 63 \text{ mm Ans.}$$

*Length of weld for fatigue loading*

From Table 10.6, we find that the stress concentration factor for parallel fillet welding is 2.7.

$\therefore$  Permissible shear stress,

$$\tau = 56 / 2.7 = 20.74 \text{ N/mm}^2$$

We know that the maximum load which the plates can carry for double parallel fillet welds ( $P$ ),

$$50 \times 10^3 = 1.414 s \times l \times \tau = 1.414 \times 12.5 \times l \times 20.74 = 367 l$$

$$\therefore l = 50 \times 10^3 / 367 = 136.2 \text{ mm}$$

Adding 12.5 for starting and stopping of weld run, we have

$$l = 136.2 + 12.5 = 148.7 \text{ mm Ans.}$$

Problem:

A plate 75 mm wide and 12.5 mm thick is joined with another plate by a single transverse weld and a double parallel fillet weld as shown in Fig. The maximum tensile and shear stresses are 70 MPa and 56 MPa respectively. Find the length of each parallel fillet weld, if the joint is subjected to both static and fatigue loading.

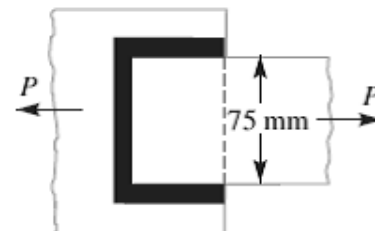

**Solution.** Given : Width = 75 mm ; Thickness = 12.5 mm ;  
 $\sigma_t = 70 \text{ MPa} = 70 \text{ N/mm}^2$  ;  $\tau = 56 \text{ MPa} = 56 \text{ N/mm}^2$ .

The effective length of weld ( $l_1$ ) for the transverse weld may be obtained by subtracting 12.5 mm from the width of the plate.

$$\therefore l_1 = 75 - 12.5 = 62.5 \text{ mm}$$

*Length of each parallel fillet for static loading*

Let  $l_2 =$  Length of each parallel fillet.

We know that the maximum load which the plate can carry is

$$P = \text{Area} \times \text{Stress} = 75 \times 12.5 \times 70 = 65\,625 \text{ N}$$

Load carried by single transverse weld,

$$P_1 = 0.707 s \times l_1 \times \sigma_t = 0.707 \times 12.5 \times 62.5 \times 70 = 38\,664 \text{ N}$$

and the load carried by double parallel fillet weld,

$$P_2 = 1.414 s \times l_2 \times \tau = 1.414 \times 12.5 \times l_2 \times 56 = 990 l_2 \text{ N}$$

$\therefore$  Load carried by the joint ( $P$ ),

$$65\,625 = P_1 + P_2 = 38\,664 + 990 l_2 \quad \text{or} \quad l_2 = 27.2 \text{ mm}$$

Adding 12.5 mm for starting and stopping of weld run, we have

$$l_2 = 27.2 + 12.5 = 39.7 \text{ say } 40 \text{ mm Ans.}$$

*Length of each parallel fillet for fatigue loading*

From Table 10.6, we find that the stress concentration factor for transverse welds is 1.5 and for parallel fillet welds is 2.7.

$\therefore$  Permissible tensile stress,

$$\sigma_t = 70 / 1.5 = 46.7 \text{ N/mm}^2$$

and permissible shear stress,

$$\tau = 56 / 2.7 = 20.74 \text{ N/mm}^2$$

Load carried by single transverse weld,

$$P_1 = 0.707 s \times l_1 \times \sigma_t = 0.707 \times 12.5 \times 62.5 \times 46.7 = 25\,795 \text{ N}$$

and load carried by double parallel fillet weld,

$$P_2 = 1.414 s \times l_2 \times \tau = 1.414 \times 12.5 \times l_2 \times 20.74 = 366 l_2 \text{ N}$$

$\therefore$  Load carried by the joint ( $P$ ),

$$65\,625 = P_1 + P_2 = 25\,795 + 366 l_2 \quad \text{or} \quad l_2 = 108.8 \text{ mm}$$

Adding 12.5 mm for starting and stopping of weld run, we have

$$l_2 = 108.8 + 12.5 = 121.3 \text{ mm Ans.}$$

### References:

1. Machine Design - V.Bandari .
2. Machine Design – R.S. Khurmi
3. Design Data hand Book - S MD Jalaludin.



Contents: Special fillet welded joints

**Special Cases of Fillet Welded Joints**

The following cases of fillet welded joints are important from the subject point of view.

**1. Circular fillet weld subjected to torsion.** Consider a circular rod connected to a rigid plate by a fillet weld as shown in Fig. 1.

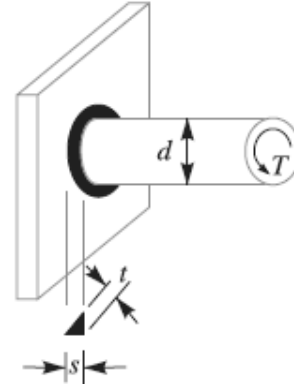

Fig. 1. Circular fillet weld subjected to torsion.

- Let  $d$  = Diameter of rod,
- $r$  = Radius of rod,
- $T$  = Torque acting on the rod,
- $s$  = Size (or leg) of weld,
- $t$  = Throat thickness,

$J$  = Polar moment of inertia of the

$$\text{weld section} = \frac{\pi t d^3}{4}$$

We know that shear stress for the material,

$$\begin{aligned} \tau &= \frac{Tr}{J} = \frac{T \times d/2}{J} \\ &= \frac{T \times d/2}{\pi t d^3 / 4} = \frac{2T}{\pi t d^2} \end{aligned}$$

This shear stress occurs in a horizontal plane along a leg of the fillet weld. The maximum shear occurs on the throat of weld which is inclined at 45° to the horizontal plane.

Length of throat,  $t = s \sin 45^\circ = 0.707 s$  and maximum shear stress,

$$\tau_{max} = \frac{2T}{\pi \times 0.707 s \times d^2} = \frac{2.83 T}{\pi s d^2}$$

**2. Circular fillet weld subjected to bending moment.**

Consider a circular rod connected to a rigid plate by a fillet weld as shown in Fig.2.

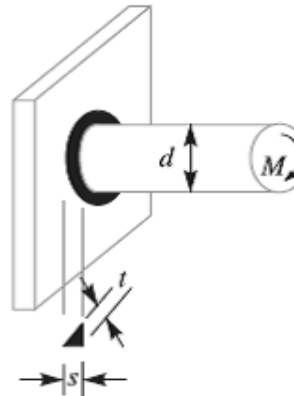

Fig.2. Circular fillet weld subjected to Bending moment.

- Let  $d$  = Diameter of rod,
- $M$  = Bending moment acting on the rod,
- $s$  = Size (or leg) of weld,
- $t$  = Throat thickness,

$Z$  = Section modulus of the weld section

$$= \frac{\pi t d^2}{4}$$

We know that the bending stress

$$\sigma_b = \frac{M}{Z} = \frac{M}{\pi t d^2 / 4} = \frac{4M}{\pi t d^2}$$

This bending stress occurs in a horizontal plane along a leg of the fillet weld. The maximum bending stress occurs on the throat of the weld which is inclined at  $45^\circ$  to the horizontal plane.

Length of throat,  $t = s \sin 45^\circ = 0.707 s$  and maximum bending stress,

$$\sigma_{b(max)} = \frac{4M}{\pi \times 0.707 s \times d^2} = \frac{5.66 M}{\pi s d^2}$$

**3. Long fillet weld subjected to torsion.** Consider a vertical plate attached to a horizontal plate by two identical fillet welds as shown in Fig.3.

Let  $T$  = Torque acting on the vertical plate,

$l$  = Length of weld,

$s$  = Size (or leg) of weld,

$t$  = Throat thickness, and

$J$  = Polar moment of inertia of the weld section

$$= 2 \times \frac{t \times l^3}{12} = \frac{t \times l^3}{6} \dots$$

It may be noted that the effect of the applied torque is to rotate the vertical plate about the  $Z$ -axis through its mid point. This rotation is resisted by shearing stresses developed between two fillet welds and the horizontal plate. It is assumed that these horizontal shearing stresses vary from zero at the  $Z$ -axis and maximum at the ends of the plate. This variation of shearing stress is analogous to the variation of normal stress over the depth ( $l$ ) of a beam subjected to pure bending.

Therefore, Shear stress,

$$\tau = \frac{T \times l/2}{t \times l^3 / 6} = \frac{3T}{t \times l^2}$$

The maximum shear stress occurs at the throat and is given by

$$\tau_{max} = \frac{3T}{0.707s \times l^2} = \frac{4.242 T}{s \times l^2}$$

**References:**

1. Machine Design - V.Bandari .
2. Machine Design – R.S. Khurmi
3. Design Data hand Book - S MD Jalaludin.



Contents: Unsymmetrical welded joints

**Axially Loaded Unsymmetrical Welded Sections**

Sometimes unsymmetrical sections such as angles, channels, T-sections etc., welded on the flange edges are loaded axially as shown in Fig. In such cases, the lengths of weld should be proportioned in such a way that the sum of resisting moments of the welds about the gravity axis is zero. Consider an angle section as shown in Fig.

Let  $l_a$  = Length of weld at the top,

$l_b$  = Length of weld at the bottom,

$l$  = Total length of weld =  $l_a + l_b$

$P$  = Axial load,

$a$  = Distance of top weld from gravity axis,

$b$  = Distance of bottom weld from gravity axis, and

$f$  = Resistance offered by the weld per unit length.



**Fig.** Axially loaded unsymmetrical welded section

Moment of the top weld about gravity axis

$$= l_a \times f \times a$$

And moment of the bottom weld about gravity axis

$$= l_b \times f \times b$$

Since the sum of the moments of the weld about the gravity axis must be zero, therefore,

$$l_a \times f \times a - l_b \times f \times b = 0$$

$$\text{or } l_a \times a = l_b \times b \quad \dots(i)$$

We know that

$$l = l_a + l_b \quad \dots(ii)$$

From equations (i) and (ii), we have

$$l_a = \frac{l \times b}{a + b}, \quad \text{and} \quad l_b = \frac{l \times a}{a + b}$$

**References:**

1. Machine Design - V.Bandari .
2. Machine Design – R.S. Khurmi
3. Design Data hand Book - S MD Jalaludin.



**Eccentrically Loaded Welded Joints**

An eccentric load may be imposed on welded joints in many ways. The stresses induced on the joint may be of different nature or of the same nature. The induced stresses are combined depending upon the nature of stresses. When the shear and bending stresses are simultaneously present in a joint (see case 1), then maximum stresses are as follows:

Maximum normal stress,

$$\sigma_{t(max)} = \frac{\sigma_b}{2} + \frac{1}{2} \sqrt{(\sigma_b)^2 + 4 \tau^2}$$

And Maximum shear stress,

$$\tau_{max} = \frac{1}{2} \sqrt{(\sigma_b)^2 + 4 \tau^2}$$

Where  $\sigma_b$  = Bending stress, and

$\tau$  = Shear stress.

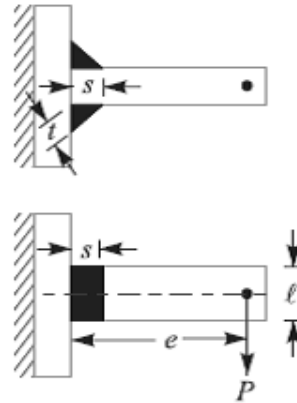

Fig.1. Eccentrically loaded welded joint

When the stresses are of the same nature, these may be combined vectorially (see case 2).

We shall now discuss the two cases of eccentric loading as follows:

**Case 1**

Consider a T-joint fixed at one end and subjected to an eccentric load  $P$  at a distance  $e$  as shown in Fig. 1

Let  $s$  = Size of weld,

$l$  = Length of weld, and

$t$  = Throat thickness.

The joint will be subjected to the following two types of stresses:

1. Direct shear stress due to the shear force  $P$  acting at the welds, and
2. Bending stress due to the bending moment  $P \times e$ .

We know that area at the throat,

$$\begin{aligned} A &= \text{Throat thickness} \times \text{Length of weld} \\ &= t \times l \times 2 = 2 t \times l \dots (\text{For double fillet weld}) \\ &= 2 \times 0.707 s \times l = 1.414 s \times l \dots (\text{since, } t = s \cos 45^\circ = 0.707 s) \end{aligned}$$

Shear stress in the weld (assuming uniformly distributed),

$$\tau = \frac{P}{A} = \frac{P}{1.414 s \times l}$$

Section modulus of the weld metal through the throat,

$$Z = \frac{t \times l^2}{6} \times 2 \quad \dots(\text{For both sides weld})$$

$$= \frac{0.707 s \times l^2}{6} \times 2 = \frac{s \times l^2}{4.242}$$

Bending moment,  $M = P \times e$

$$\therefore \text{Bending stress, } \sigma_b = \frac{M}{Z} = \frac{P \times e \times 4.242}{s \times l^2} = \frac{4.242 P \times e}{s \times l^2}$$

We know that the maximum normal stress,

$$\sigma_{t(max)} = \frac{1}{2} \sigma_b + \frac{1}{2} \sqrt{(\sigma_b)^2 + 4 \tau^2}$$

And maximum shear stress,

$$\tau_{max} = \frac{1}{2} \sqrt{(\sigma_b)^2 + 4 \tau^2}$$

**Case 2**

When a welded joint is loaded eccentrically as shown in Fig.2, the following two types of the stresses are induced:

1. Direct or primary shear stress, and
2. Shear stress due to turning moment.

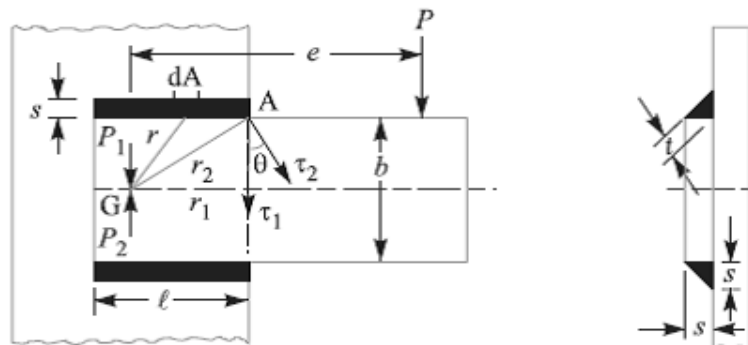

Fig.2 eccentrically loaded welded joint.

Let  $P$  = Eccentric load,

$e$  = Eccentricity i.e. perpendicular distance between the line of action of load and centre of gravity (G) of the throat section or fillets,

$l$  = Length of single weld,

$s$  = Size or leg of weld, and

$t$  = Throat thickness.

Let two loads  $P_1$  and  $P_2$  (each equal to  $P$ ) are introduced at the centre of gravity 'G' of the weld system. The effect of load  $P_1 = P$  is to produce direct shear stress which is assumed to be uniform over the entire weld length. The effect of load  $P_2 = P$  is to produce a turning moment of magnitude  $P \times e$  which tends to rotate the joint about the centre of gravity 'G' of the weld system. Due to the turning moment, secondary shear stress is induced.

We know that the direct or primary shear stress,

$$\begin{aligned} \tau_1 &= \frac{\text{Load}}{\text{Throat area}} = \frac{P}{A} = \frac{P}{2 t \times l} \\ &= \frac{P}{2 \times 0.707 s \times l} = \frac{P}{1.414 s \times l} \end{aligned}$$

Since the shear stress produced due to the turning moment ( $T = P \times e$ ) at any section is proportional to its radial distance from G, therefore stress due to  $P \times e$  at the point A is proportional to AG ( $r_2$ ) and is in a direction at right angles to AG. In other words,

$$\begin{aligned} \frac{\tau_2}{r_2} &= \frac{\tau}{r} = \text{Constant} \\ \tau &= \frac{\tau_2}{r_2} \times r \end{aligned} \quad \dots(i)$$

Where  $\tau_2$  is the shear stress at the maximum distance ( $r_2$ ) and  $\tau$  is the shear stress at any distance  $r$ . Consider a small section of the weld having area  $dA$  at a distance  $r$  from G.

Shear force on this small section

$$= \tau \times dA$$

And turning moment of this shear force about G,

$$dT = \tau \times dA \times r = \frac{\tau_2}{r_2} \times dA \times r^2 \quad \dots \text{ [ From equation (i) ]}$$

Total turning moment over the whole weld area,



$$T = P \times e = \int_{r_2}^{\tau_2} \tau_2 \times dA \times r^2 = \frac{\tau_2}{r_2} \int dA \times r^2$$

$$= \frac{\tau_2}{r_2} \times J \quad (\because J = \int dA \times r^2)$$

Where J = Polar moment of inertia of the throat area about G.

□ Shear stress due to the turning moment i.e. secondary shear stress,

$$\tau_2 = \frac{T \times r_2}{J} = \frac{P \times e \times r_2}{J}$$

In order to find the resultant stress, the primary and secondary shear stresses are combined vectorially.

Resultant shear stress at A,

$$\tau_A = \sqrt{(\tau_1)^2 + (\tau_2)^2 + 2\tau_1 \times \tau_2 \times \cos \theta}$$

$\theta =$  Angle between  $\tau_1$  and  $\tau_2$ , and

$$\cos \theta = r_1 / r_2$$

#### References:

1. Machine Design - V.Bandari .
2. Machine Design – R.S. Khurmi
3. Design Data hand Book - S MD Jalaludin

Problem:

A welded joint as shown in Fig. 10.24, is subjected to an eccentric load of 2 kN. Find the size of weld, if the maximum shear stress in the weld is 25 MPa.

**Solution.** Given:  $P = 2\text{ kN} = 2000\text{ N}$ ;  $e = 120\text{ mm}$  ;  
 $l = 40\text{ mm}$  ;  $\tau_{max} = 25\text{ MPa} = 25\text{ N/mm}^2$

Let  $s =$  Size of weld in mm, and  
 $t =$  Throat thickness.

The joint, as shown in Fig. 10.24, will be subjected to direct shear stress due to the shear force,  $P = 2000\text{ N}$  and bending stress due to the bending moment of  $P \times e$ .

We know that area at the throat,

$$\begin{aligned} A &= 2t \times l = 2 \times 0.707 s \times l \\ &= 1.414 s \times l \\ &= 1.414 s \times 40 = 56.56 \times s \text{ mm}^2 \end{aligned}$$

$$\therefore \text{Shear stress, } \tau = \frac{P}{A} = \frac{2000}{56.56 \times s} = \frac{35.4}{s} \text{ N/mm}^2$$

$$\text{Bending moment, } M = P \times e = 2000 \times 120 = 240 \times 10^3 \text{ N-mm}$$

Section modulus of the weld through the throat,

$$Z = \frac{s \times l^2}{4.242} = \frac{s (40)^2}{4.242} = 377 \times s \text{ mm}^3$$

$$\therefore \text{Bending stress, } \sigma_b = \frac{M}{Z} = \frac{240 \times 10^3}{377 \times s} = \frac{636.6}{s} \text{ N/mm}^2$$

We know that maximum shear stress ( $\tau_{max}$ ),

$$25 = \frac{1}{2} \sqrt{(\sigma_b)^2 + 4 \tau^2} = \frac{1}{2} \sqrt{\left(\frac{636.6}{s}\right)^2 + 4 \left(\frac{35.4}{s}\right)^2} = \frac{320.3}{s}$$

$$\therefore s = 320.3 / 25 = 12.8 \text{ mm Ans.}$$

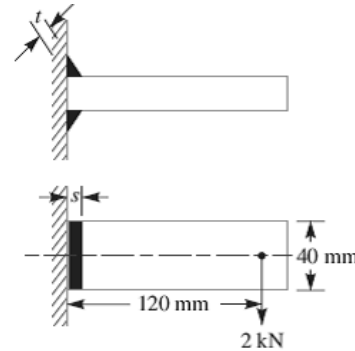

Problem:

A bracket carrying a load of 15 kN is to be welded as shown in Fig. Find the size of weld required if the allowable shear stress is not to exceed 80 MPa.

**Solution.** Given :  $P = 15\text{ kN} = 15 \times 10^3\text{ N}$  ;  $\tau = 80\text{ MPa} = 80\text{ N/mm}^2$  ;  $b = 80\text{ mm}$  ;  
 $l = 50\text{ mm}$  ;  $e = 125\text{ mm}$

Let  $s =$  Size of weld in mm, and  
 $t =$  Throat thickness.

We know that the throat area,

$$\begin{aligned} A &= 2 \times t \times l = 2 \times 0.707 s \times l \\ &= 1.414 s \times l = 1.414 \times s \times 50 = 70.7 s \text{ mm}^2 \end{aligned}$$

∴ Direct or primary shear stress,

$$\tau_1 = \frac{P}{A} = \frac{15 \times 10^3}{70.7 s} = \frac{212}{s} \text{ N/mm}^2$$

$$J = \frac{t l (3b^2 + l^2)}{6} = \frac{0.707 s \times 50 [3(80)^2 + (50)^2]}{6} \text{ mm}^4$$

$$= 127\,850 s \text{ mm}^4$$

... (∵ t = 0.707 s)

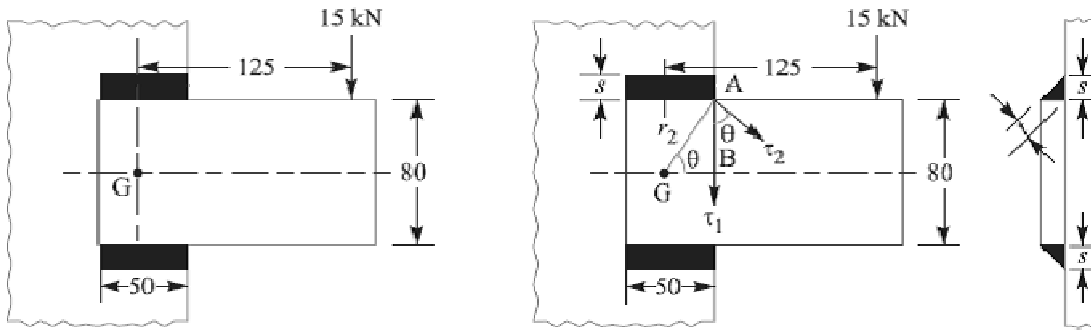

All dimensions in mm,

∴ Maximum radius of the weld,

$$r_2 = \sqrt{(AB)^2 + (BG)^2} = \sqrt{(40)^2 + (25)^2} = 47 \text{ mm}$$

Shear stress due to the turning moment *i.e.* secondary shear stress,

$$\tau_2 = \frac{P \times e \times r_2}{J} = \frac{15 \times 10^3 \times 125 \times 47}{127\,850 s} = \frac{689.3}{s} \text{ N/mm}^2$$

and

$$\cos \theta = \frac{r_1}{r_2} = \frac{25}{47} = 0.532$$

We know that resultant shear stress,

$$\tau = \sqrt{(\tau_1)^2 + (\tau_2)^2 + 2 \tau_1 \times \tau_2 \cos \theta}$$

$$80 = \sqrt{\left(\frac{212}{s}\right)^2 + \left(\frac{689.3}{s}\right)^2 + 2 \times \frac{212}{s} \times \frac{689.3}{s} \times 0.532} = \frac{822}{s}$$

∴

$$s = 822 / 80 = 10.3 \text{ mm Ans.}$$

**References:**

1. Machine Design - V.Bandari
2. Machine Design – R.S. Khurmi
3. Design Data hand Book - S MD Jalaludin.

**Introduction to Screwed Joints:**

A screw thread is formed by cutting a continuous helical groove on a cylindrical surface. A screw made by cutting a single helical groove on the cylinder is known as **single threaded** (or single-start) screw and if a second thread is cut in the space between the grooves of the first, a **double threaded** (or double-start) screw is formed. Similarly, triple and quadruple (i.e. multiple-start) threads may be formed. The helical grooves may be cut either **right hand** or **left hand**.

A screwed joint is mainly composed of two elements i.e. a bolt and nut. The screwed joints are widely used where the machine parts are required to be readily connected or disconnected without damage to the machine or the fastening. This may be for the purpose of holding or adjustment in assembly or service inspection, repair, or replacement or it may be for the manufacturing or assembly reasons. The parts may be rigidly connected or provisions may be made for predetermined relative motion.

**Advantages and Disadvantages of Screwed Joints**

Following are the advantages and disadvantages of the screwed joints.

**Advantages**

1. Screwed joints are highly reliable in operation.
2. Screwed joints are convenient to assemble and disassemble.
3. A wide range of screwed joints may be adapted to various operating conditions.
4. Screws are relatively cheap to produce due to standardization and highly efficient manufacturing processes.

**Disadvantages**

The main disadvantage of the screwed joints is the stress concentration in the threaded portions which are vulnerable points under variable load conditions.

**Note :** The strength of the screwed joints is not comparable with that of riveted or welded joints.

**Important Terms Used in Screw Threads**

The following terms used in screw threads, as shown in Fig. 1, are important from the subject point of view:

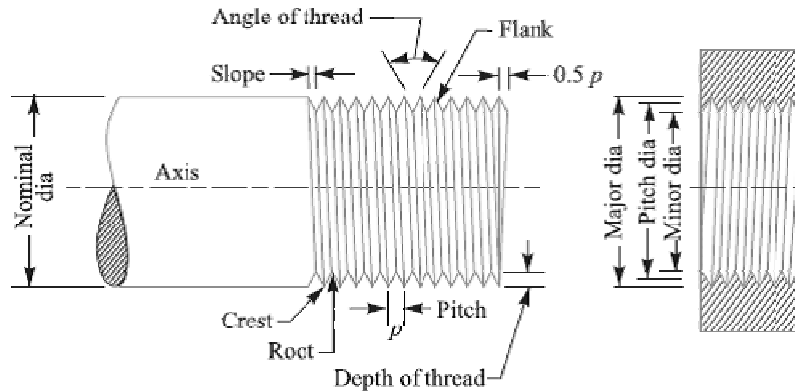

Fig.1 Terms used in screw threads

1. **Major diameter.** It is the largest diameter of an external or internal screw thread. The screw is specified by this diameter. It is also known as **outside** or **nominal diameter**.
2. **Minor diameter.** It is the smallest diameter of an external or internal screw thread. It is also known as **core** or **root diameter**.
3. **Pitch diameter.** It is the diameter of an imaginary cylinder, on a cylindrical screw thread, the surface of which would pass through the thread at such points as to make equal the width of the thread and the width of the spaces between the threads. It is also called an **effective diameter**. In a nut and bolt assembly, it is the diameter at which the ridges on the bolt are in complete touch with the ridges of the corresponding nut.
4. **Pitch.** It is the distance from a point on one thread to the corresponding point on the next. This is measured in an axial direction between corresponding points in the same axial plane. Mathematically,

$$\text{Pitch} = \frac{1}{\text{No. of threads per unit length of screw}}$$

5. **Lead.** It is the distance between two corresponding points on the same helix. It may also be defined as the distance which a screw thread advances axially in one rotation of the nut. Lead is equal to the pitch in case of single start threads, it is twice the pitch in double start, thrice the pitch in triple start and so on.
6. **Crest.** It is the top surface of the thread.
7. **Root.** It is the bottom surface created by the two adjacent flanks of the thread.
8. **Depth of thread.** It is the perpendicular distance between the crest and root.
9. **Flank.** It is the surface joining the crest and root.

**10. Angle of thread.** It is the angle included by the flanks of the thread.

**11. Slope.** It is half the pitch of the thread.

**References:**

1. Machine Design - V.Bandari .
2. Machine Design – R.S. Khurmi
3. Design Data hand Book - S MD Jalaludin.



**Stresses in Screwed Fastening due to Static Loading**

The following stresses in screwed fastening due to static loading are important from the subject point of view:

1. Internal stresses due to screwing up forces,
2. Stresses due to external forces, and
3. Stress due to combination of stresses at (1) and (2).

**Initial Stresses due to Screwing up Forces**

The following stresses are induced in a bolt, screw or stud when it is screwed up tightly.

**1. Tensile stress due to stretching of bolt.** Since none of the above mentioned stresses are accurately determined, therefore bolts are designed on the basis of direct tensile stress with a large factor of safety in order to account for the indeterminate stresses. The initial tension in a bolt, based on experiments, may be found by the relation

$$P_i = 2840 d \text{ N}$$

Where  $P_i$  = Initial tension in a bolt, and

$d$  = Nominal diameter of bolt, in mm.

The above relation is used for making a joint fluid tight like steam engine cylinder cover joints etc. When the joint is not required as tight as fluid-tight joint, then the initial tension in a bolt may be reduced to half of the above value. In such cases

$$P_i = 1420 d \text{ N}$$

The small diameter bolts may fail during tightening, therefore bolts of smaller diameter (less than M 16 or M 18) are not permitted in making fluid tight joints. If the bolt is not initially stressed, then the maximum safe axial load which may be applied to it, is given by

$P$  = Permissible stress  $\times$  Cross-sectional area at bottom of the thread

$$\text{Stress area} = \frac{\pi}{4} \left( \frac{d_p + d_c}{2} \right)^2$$

Where  $d_p$  = Pitch diameter, and

$d_c$  = Core or minor diameter.

**Stresses due to External Forces**

The following stresses are induced in a bolt when it is subjected to an external load.

**1. Tensile stress.** The bolts, studs and screws usually carry a load in the direction of the bolt axis which induces a tensile stress in the bolt.

Let  $d_c$  = Root or core diameter of the thread, and

$\sigma_t$  = Permissible tensile stress for the bolt material.

We know that external load applied,

$$P = \frac{\pi}{4} (d_c)^2 \sigma_t$$

$$d_c = \sqrt{\frac{4P}{\pi \sigma_t}}$$

**Notes:** (a) if the external load is taken up by a number of bolts, then

$$P = \frac{\pi}{4} (d_c)^2 \sigma_t \times n$$

(b) In case the standard table is not available, then for coarse threads,  $d_c = 0.84 d$ , where  $d$  is the nominal diameter of bolt.

**2. Shear stress.** Sometimes, the bolts are used to prevent the relative movement of two or more parts, as in case of flange coupling, and then the shear stress is induced in the bolts. The shear stresses should be avoided as far as possible. It should be noted that when the bolts are subjected to direct shearing loads, they should be located in such a way that the shearing load comes upon the body (i.e. shank) of the bolt and not upon the threaded portion. In some cases, the bolts may be relieved of shear load by using shear pins. When a number of bolts are used to share the shearing load, the finished bolts should be fitted to the reamed holes.

Let  $d$  = Major diameter of the bolt, and

$n$  = Number of bolts.

Shearing load carried by the bolts,

$$P_s = \frac{\pi}{4} \times d^2 \times \tau \times n \quad \text{or} \quad d = \sqrt{\frac{4P_s}{\pi \tau n}}$$

**3. Combined tension and shear stress.** When the bolt is subjected to both tension and shear loads, as in case of coupling bolts or bearing, then the diameter of the shank of the bolt is obtained from the shear load and that of threaded part from the tensile load. A diameter slightly larger than that required for either shear or tension may be assumed and stresses due to combined load should be checked for the following principal stresses.

Maximum principal shear stress,

$$\tau_{max} = \frac{1}{2} \sqrt{(\sigma_t)^2 + 4\tau^2}$$

And maximum principal tensile stress,

$$\sigma_{t(max)} = \frac{\sigma_t}{2} + \frac{1}{2} \sqrt{(\sigma_t)^2 + 4\tau^2}$$



These stresses should not exceed the safe permissible values of stresses.

**References:**

1. Machine Design - V.Bandari .
2. Machine Design – R.S. Khurmi
3. Design Data hand Book - S MD Jalaludin.



Contents: Stresses due to combined loading and design of cylindrical cover plates.

### Stress due to Combined Forces

The resultant axial load on a bolt depends upon the following factors:

1. The initial tension due to tightening of the bolt,
2. The external load, and
3. The relative elastic yielding (springiness) of the bolt and the connected members.

When the connected members are very yielding as compared with the bolt, which is a soft gasket, as shown in Fig. 1 (a), then the resultant load on the bolt is approximately equal to the sum of the initial tension and the external load. On the other hand, if the bolt is very yielding as compared with the connected members, as shown in Fig. 1(b), then the resultant load will be either the initial tension or the external load, whichever is greater. The actual conditions usually lie between the two extremes. In order to determine the resultant axial load ( $P$ ) on the bolt, the following equation may be used :

$$P = P_1 + \frac{a}{1+a} \times P_2 = P_1 + K.P_2 \quad \dots \left( \text{Substituting } \frac{a}{1+a} = K \right)$$

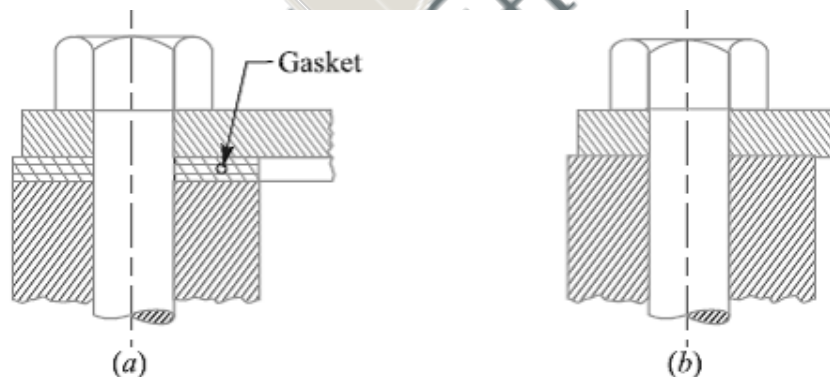

Fig.1

Where  $P_1$  = Initial tension due to tightening of the bolt,

$P_2$  = External load on the bolt, and

$a$  = Ratio of elasticity of connected parts to the elasticity of bolt.

For soft gaskets and large bolts, the value of  $a$  is high and the value of  $a/(1+a)$  is approximately equal to unity, so that the resultant load is equal to the sum of the initial tension and the external load. For hard gaskets or metal to metal contact surfaces and with small bolts, the value of  $a$  is small and the resultant load is mainly due to the initial tension (or external load, in rare case it is greater than initial tension). The value of ' $a$ ' may be estimated by the designer to obtain an approximate value for the resultant load. The values of

$a/(1+a)$  (i.e.  $K$ ) for various type of joints are shown in the following table. The designer thus has control over the influence on the resultant load on a bolt by proportioning the sizes of the connected parts and bolts and by specifying initial tension in the bolt.

Values of  $K$  for various types of joints.

Type of joint	$K = \frac{a}{1+a}$
Metal to metal joint with through bolts	0.00 to 0.10
Hard copper gasket with long through bolts	0.25 to 0.50
Soft copper gasket with long through bolts	0.50 to 0.75
Soft packing with through bolts	0.75 to 1.00
Soft packing with studs	1.00

**Design of Cylinder Covers**

The cylinder covers may be secured by means of bolts or studs, but studs are preferred. The possible arrangement of securing the cover with bolts and studs is shown in Fig. 2 (a) and (b) respectively. The bolts or studs, cylinder cover plate and cylinder flange may be designed as discussed below:

**1. Design of bolts or studs**

In order to find the size and number of bolts or studs, the following procedure may be adopted.

- Let  $D$  = Diameter of the cylinder,
- $p$  = Pressure in the cylinder,
- $d_c$  = Core diameter of the bolts or studs,
- $n$  = Number of bolts or studs, and
- $\sigma_{tb}$  = Permissible tensile stress for the bolt or stud material.

We know that upward force acting on the cylinder cover,

$$P = \frac{\pi}{4} (D^2) p \quad \dots(i)$$

This force is resisted by  $n$  number of bolts or studs provided on the cover.

Resisting force offered by  $n$  number of bolts or studs,

$$P = \frac{\pi}{4} (d_c)^2 \sigma_{tb} \times n \quad \dots(ii)$$

From equations (i) and (ii), we have

$$\frac{\pi}{4} (D^2) p = \frac{\pi}{4} (d_c)^2 \sigma_{tb} \times n \quad \dots(ii)$$

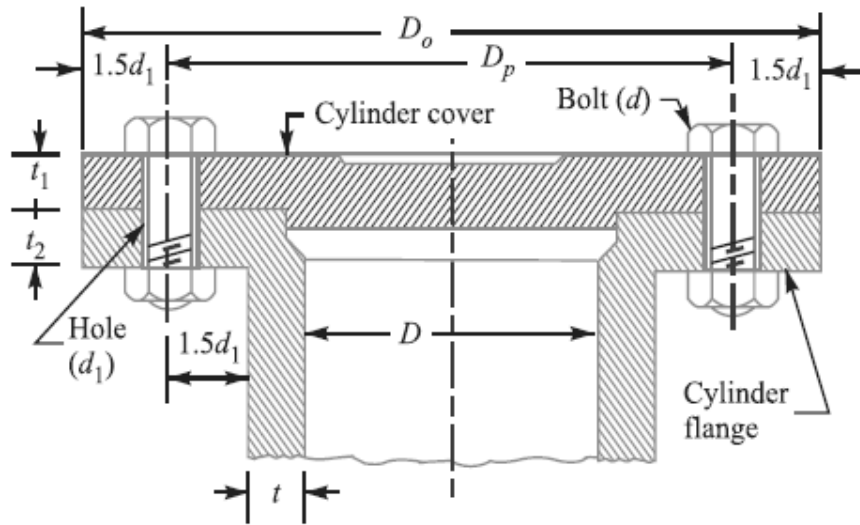

(a) Arrangement of securing the cylinder cover with bolts.

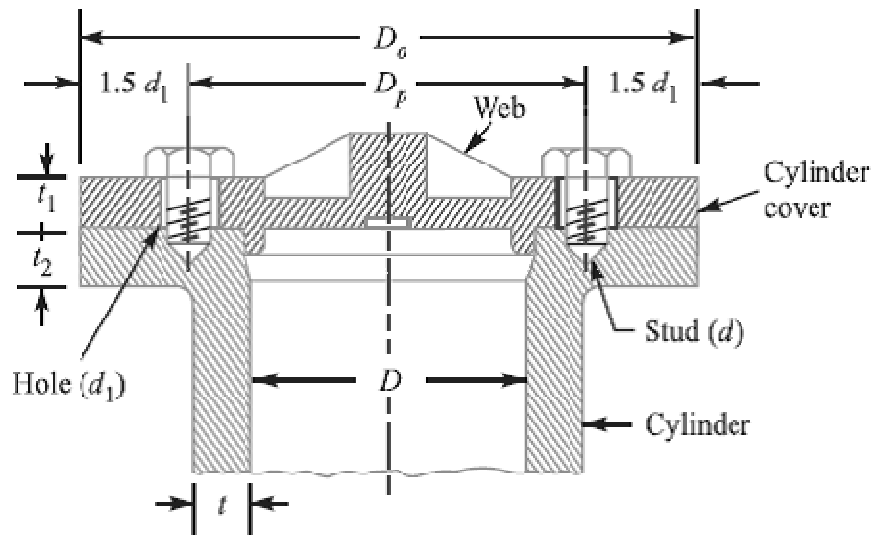

Fig. 2.

From this equation, the number of bolts or studs may be obtained, if the size of the bolt or stud is known and *vice-versa*. Usually the size of the bolt is assumed. If the value of  $n$  as obtained from the above relation is odd or a fraction, then next higher even number is adopted. The bolts or studs are screwed up tightly, along with metal gasket or asbestos packing, in order to provide a leak proof joint. We have already discussed that due to the tightening of bolts, sufficient tensile stress is produced in the bolts or studs. This may break the bolts or studs, even before any load due to internal pressure acts upon them. Therefore a bolt or a stud less than 16 mm diameter should never be used.

The tightness of the joint also depends upon the circumferential pitch of the bolts or studs. The circumferential pitch should be between  $20 d_1$  and  $30 d_1$ , where  $d_1$  is the diameter of the hole in mm for bolt or stud. The pitch circle diameter ( $D_p$ ) is usually taken as  $D + 2t + 3d_1$  and outside diameter of the cover is kept as

$$D_0 = D_p + 3d_1 = D + 2t + 6d_1$$

where  $t$  = Thickness of the cylinder wall.

**2. Design of cylinder cover plate**

The thickness of the cylinder cover plate ( $t_1$ ) and the thickness of the cylinder flange ( $t_2$ ) may be determined as discussed below:

Let us consider the semi-cover plate as shown in Fig. 3. The internal pressure in the cylinder tries to lift the cylinder cover while the bolts or studs try to retain it in its position. But the centres of pressure of these two loads do not coincide. Hence, the cover plate is subjected to bending stress. The point X is the centre of pressure for bolt load and the point Y is the centre of internal pressure.

We know that the bending moment at A-A,

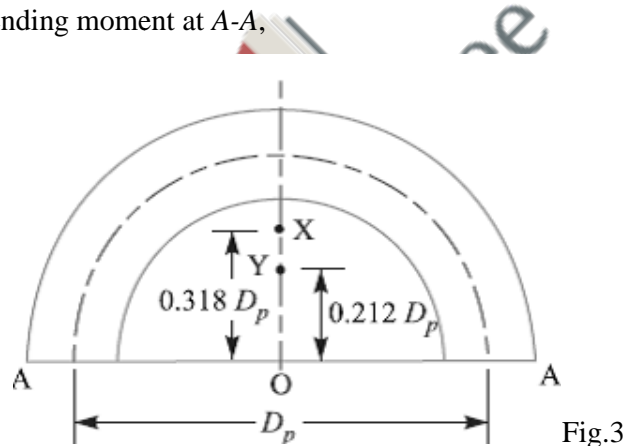

$$M = \frac{\text{Total bolt load}}{2} (OX - OY) = \frac{P}{2} (0.318 D_p - 0.212 D_p)$$

$$= \frac{P}{2} \times 0.106 D_p = 0.053 P \times D_p$$

$$Z = \frac{1}{6} w (t_1)^2$$

Where  $w$  = Width of plate

= Outside dia. of cover plate – 2 × dia. of bolt hole

=  $D_0 - 2d_1$

Knowing the tensile stress for the cover plate material, the value of  $t_1$  may be determined by using the bending equation,

*i.e.*,  $\sigma t = M / Z$ .

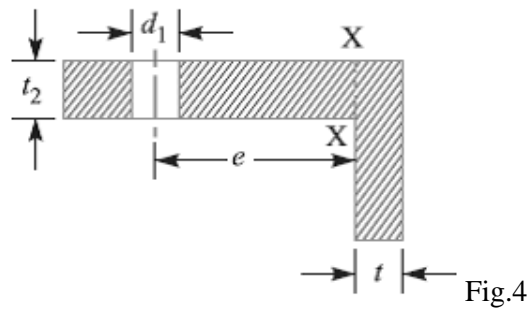

**3. Design of cylinder flange**

The thickness of the cylinder flange ( $t_2$ ) may be determined from bending consideration. A portion of the cylinder flange under the influence of one bolt is shown in Fig. 4. The load in the bolt produces bending stress in the section X-X. From the geometry of the figure, we find that eccentricity of the load from section X-X is

$e = \text{Pitch circle radius} - (\text{Radius of bolt hole} + \text{Thickness of cylinder wall})$

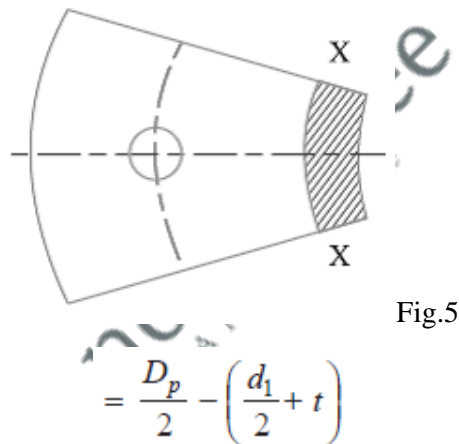

Bending moment,  $M = \text{Load on each bolt} \times e$

$$= \frac{P}{n} \times e$$

$R = \text{Cylinder radius} + \text{Thickness of cylinder wall}$

$$= \frac{D}{2} + t$$

Width of the section X-X,

$$w = \frac{2\pi R}{n}, \text{ Where } n \text{ is the number of bolts.}$$

Section modulus,

$$Z = \frac{1}{6} w (t_2)^2$$

Knowing the tensile stress for the cylinder flange material, the value of  $t_2$  may be obtained by using the bending equation *i.e.*  $\sigma_t = M / Z$ .

**References:**

1. Machine Design - V.Bandari
2. Machine Design – R.S. Khurmi
3. Design Data hand Book - S MD Jalaludin.



Problems on cylinder cover plates design

Problem:

A steam engine cylinder has an effective diameter of 350 mm and the maximum steam pressure acting on the cylinder cover is  $1.25 \text{ N/mm}^2$ . Calculate the number and size of studs required to fix the cylinder cover, assuming the permissible stress in the studs as 33 MPa.

**Solution.** Given:  $D = 350 \text{ mm}$  ;  $p = 1.25 \text{ N/mm}^2$  ;  $\sigma_t = 33 \text{ MPa} = 33 \text{ N/mm}^2$

Let  $d$  = Nominal diameter of studs,  
 $d_c$  = Core diameter of studs, and  
 $n$  = Number of studs.

We know that the upward force acting on the cylinder cover,

$$P = \frac{\pi}{4} \times D^2 \times p = \frac{\pi}{4} (350)^2 \times 1.25 = 120\,265 \text{ N} \quad \dots(i)$$

Assume that the studs of nominal diameter 24 mm are used. From Table 11.1 (coarse series), we find that the corresponding core diameter ( $d_c$ ) of the stud is 20.32 mm.

$\therefore$  Resisting force offered by  $n$  number of studs,

$$P = \frac{\pi}{4} \times (d_c)^2 \times \sigma_t \times n = \frac{\pi}{4} (20.32)^2 \times 33 \times n = 10\,700 \text{ n N} \quad \dots(ii)$$

From equations (i) and (ii), we get

$$n = 120\,265 / 10\,700 = 11.24 \text{ say } 12 \text{ Ans.}$$

Taking the diameter of the stud hole ( $d_1$ ) as 25 mm, we have pitch circle diameter of the studs,

$$D_p = D_1 + 2t + 3d_1 = 350 + 2 \times 10 + 3 \times 25 = 445 \text{ mm}$$

...(Assuming  $t = 10 \text{ mm}$ )

$\therefore$  \*Circumferential pitch of the studs

$$= \frac{\pi \times D_p}{n} = \frac{\pi \times 445}{12} = 116.5 \text{ mm}$$

We know that for a leak-proof joint, the circumferential pitch of the studs should be between  $20\sqrt{d_1}$  to  $30\sqrt{d_1}$ , where  $d_1$  is the diameter of stud hole in mm.

$\therefore$  Minimum circumferential pitch of the studs

$$= 20\sqrt{d_1} = 20\sqrt{25} = 100 \text{ mm}$$

and maximum circumferential pitch of the studs

$$= 30\sqrt{d_1} = 30\sqrt{25} = 150 \text{ mm}$$

Since the circumferential pitch of the studs obtained above lies within 100 mm to 150 mm, therefore the size of the bolt chosen is satisfactory.

$\therefore$  Size of the bolt = M 24 Ans.



Problem:

A mild steel cover plate is to be designed for an inspection hole in the shell of a pressure vessel. The hole is 120 mm in diameter and the pressure inside the vessel is 6 N/mm<sup>2</sup>. Design the cover plate along with the bolts. Assume allowable tensile stress for mild steel as 60 MPa and for bolt material as 40 MPa.

**Solution.** Given :  $D = 120$  mm or  $r = 60$  mm ;  $p = 6$  N/mm<sup>2</sup> ;  $\sigma_t = 60$  MPa = 60 N/mm<sup>2</sup> ;  $\sigma_{tb} = 40$  MPa = 40 N/mm<sup>2</sup>

First for all, let us find the thickness of the pressure vessel. According to Lamé's equation, thickness of the pressure vessel,

$$t = r \left[ \sqrt{\frac{\sigma_t + p}{\sigma_t - p}} - 1 \right] = 60 \left[ \sqrt{\frac{60 + 6}{60 - 6}} - 1 \right] = 6 \text{ mm}$$

Let us adopt  $t = 10$  mm

*Design of bolts*

Let  $d$  = Nominal diameter of the bolts,  
 $d_c$  = Core diameter of the bolts, and  
 $n$  = Number of bolts.

We know that the total upward force acting on the cover plate (or on the bolts),

$$P = \frac{\pi}{4} (D)^2 p = \frac{\pi}{4} (120)^2 6 = 67\,867 \text{ N} \quad \dots(i)$$

Let the nominal diameter of the bolt is 24 mm. From Table 11.1 (coarse series), we find that the corresponding core diameter ( $d_c$ ) of the bolt is 20.32 mm.

$\therefore$  Resisting force offered by  $n$  number of bolts,

$$P = \frac{\pi}{4} (d_c)^2 \sigma_{tb} \times n = \frac{\pi}{4} (20.32)^2 40 \times n = 67\,867 \text{ N} = 12\,973 \text{ n N} \quad \dots(ii)$$

From equations (i) and (ii), we get

$$n = 67\,867 / 12\,973 = 5.23 \text{ say } 6$$

Taking the diameter of the bolt hole ( $d_1$ ) as 25 mm, we have pitch circle diameter of bolts,

$$D_p = D + 2t + 3d_1 = 120 + 2 \times 10 + 3 \times 25 = 215 \text{ mm}$$

$\therefore$  Circumferential pitch of the bolts

$$= \frac{\pi \times D_p}{n} = \frac{\pi \times 215}{6} = 112.6 \text{ mm}$$

We know that for a leak proof joint, the circumferential pitch of the bolts should lie between  $20\sqrt{d_1}$  to  $30\sqrt{d_1}$ , where  $d_1$  is the diameter of the bolt hole in mm.

$\therefore$  Minimum circumferential pitch of the bolts

$$= 20\sqrt{d_1} = 20\sqrt{25} = 100 \text{ mm}$$

and maximum circumferential pitch of the bolts

$$= 30\sqrt{d_1} = 30\sqrt{25} = 150 \text{ mm}$$

Since the circumferential pitch of the bolts obtained above is within 100 mm and 150 mm, therefore size of the bolt chosen is satisfactory.

∴ Size of the bolt = M 24 Ans.

### *Design of cover plate*

Let  $t_1$  = Thickness of the cover plate.

The semi-cover plate is shown in Fig. 11.27.

We know that the bending moment at A-A,

$$\begin{aligned} M &= 0.053 P \times D_p \\ &= 0.053 \times 67\,860 \times 215 \\ &= 773\,265 \text{ N-mm} \end{aligned}$$

Outside diameter of the cover plate,

$$D_o = D_p + 3d_1 = 215 + 3 \times 25 = 290 \text{ mm}$$

Width of the plate,

$$w = D_o - 2d_1 = 290 - 2 \times 25 = 240 \text{ mm}$$

∴ Section modulus,

$$Z = \frac{1}{6} w(t_1)^2 = \frac{1}{6} \times 240 (t_1)^2 = 40 (t_1)^2 \text{ mm}^3$$

We know that bending (tensile) stress,

$$\sigma_t = M/Z \quad \text{or} \quad 60 = 773\,265 / 40 (t_1)^2$$

∴  $(t_1)^2 = 773\,265 / 40 \times 60 = 322 \quad \text{or} \quad t_1 = 18 \text{ mm Ans.}$

### References:

1. Machine Design - V.Bandari .
2. Machine Design – R.S. Khurmi
3. Design Data hand Book - S MD Jalaludin.



Contents: Design of bolted joints under eccentric loading-1

**Eccentric Load Acting Parallel to the Axis of Bolts**

Consider a bracket having a rectangular base bolted to a wall by means of four bolts as shown in Fig.1. A little consideration will show that each bolt is subjected to a direct tensile load of

$$W_{t1} = \frac{W}{n}, \text{ where } n \text{ is the number of bolts.}$$

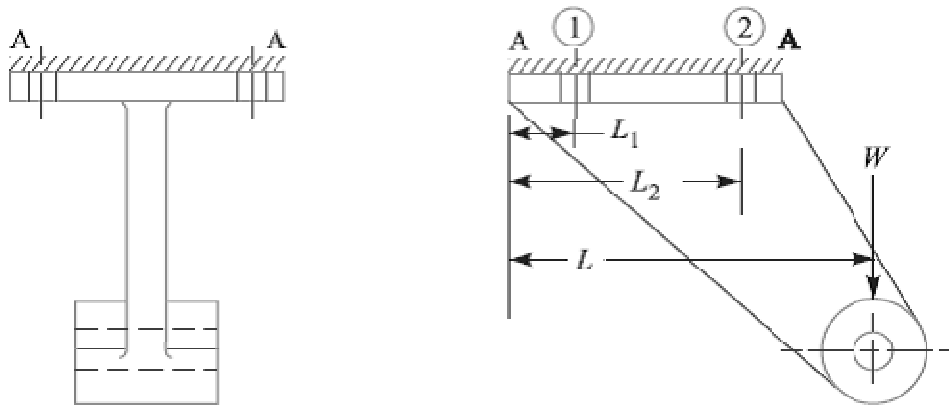

Fig.1. Eccentric load acting parallel to the axis of bolts.

Further the load  $W$  tends to rotate the bracket about the edge A-A. Due to this, each bolt is stretched by an amount that depends upon its distance from the tilting edge. Since the stress is a function of elongation, therefore each bolt will experience a different load which also depends upon the distance from the tilting edge. For convenience, all the bolts are made of same size. In case the flange is heavy, it may be considered as a rigid body.

Let  $w$  be the load in a bolt per unit distance due to the turning effect of the bracket and let  $W_1$  and  $W_2$  be the loads on each of the bolts at distances  $L_1$  and  $L_2$  from the tilting edge.

Load on each bolt at distance  $L_1$ ,

$$W_1 = w.L_1$$

And moment of this load about the tilting edge

$$= w.L_1 \times L_1 = w (L_1)^2$$

Similarly, load on each bolt at distance  $L_2$ ,

$$W_2 = w.L_2$$

And moment of this load about the tilting edge

$$= w.L_2 \times L_2 = w (L_2)^2$$

So, Total moment of the load on the bolts about the tilting edge

$$= 2w (L_1)^2 + 2w (L_2)^2 \dots(i)$$

... (Since, there are two bolts each at distance of  $L_1$  and  $L_2$ )

Also the moment due to load  $W$  about the tilting edge

$$= W.L \dots (ii)$$

From equations (i) and (ii), we have

$$W.L = 2w(L_1)^2 + 2w(L_2)^2 \quad \text{or} \quad w = \frac{W.L}{2[(L_1)^2 + (L_2)^2]} \dots(iii)$$

It may be noted that the most heavily loaded bolts are those which are situated at the greatest distance from the tilting edge. In the case discussed above, the bolts at distance  $L_2$  are heavily loaded.

So, Tensile load on each bolt at distance  $L_2$ ,

$$W_{t2} = W_2 = w.L_2 = \frac{W.L.L_2}{2[(L_1)^2 + (L_2)^2]} \dots [\text{From equation (iii)}]$$

And the total tensile load on the most heavily loaded bolt,

$$W_t = W_{t1} + W_{t2} \dots (iv)$$

If  $d_c$  is the core diameter of the bolt and  $\sigma_t$  is the tensile stress for the bolt material, then total tensile load,

$$W_t = \frac{\pi}{4} (d_c)^2 \sigma_t \dots(v)$$

From equations (iv) and (v), the value of  $d_c$  may be obtained.

Problem:

A bracket, as shown in Fig.1, supports a load of 30 kN. Determine the size of bolts, if the maximum allowable tensile stress in the bolt material is 60 MPa. The distances are:  $L_1 = 80$  mm,  $L_2 = 250$  mm, and  $L = 500$  mm.

**Solution.** Given :  $W = 30$  kN ;  $\sigma_t = 60$  MPa = 60 N/mm<sup>2</sup> ;  $L_1 = 80$  mm ;  $L_2 = 250$  mm ;  $L = 500$  mm

We know that the direct tensile load carried by each bolt,

$$W_{t1} = \frac{W}{n} = \frac{30}{4} = 7.5 \text{ kN}$$

and load in a bolt per unit distance,

$$w = \frac{W.L}{2[(L_1)^2 + (L_2)^2]} = \frac{30 \times 500}{2[(80)^2 + (250)^2]} = 0.109 \text{ kN/mm}$$

Since the heavily loaded bolt is at a distance of  $L_2$  mm from the tilting edge, therefore load on the heavily loaded bolt,

$$W_{\Omega} = wL_2 = 0.109 \times 250 = 27.25 \text{ kN}$$

$\therefore$  Maximum tensile load on the heavily loaded bolt,

$$W_t = W_{d1} + W_{\Omega} = 7.5 + 27.25 = 34.75 \text{ kN} = 34\,750 \text{ N}$$

Let  $d_c$  = Core diameter of the bolts.

We know that the maximum tensile load on the bolt ( $W_t$ ),

$$34\,750 = \frac{\pi}{4} (d_c)^2 \sigma_t = \frac{\pi}{4} (d_c)^2 60 = 47 (d_c)^2$$

$$\therefore (d_c)^2 = 34\,750 / 47 = 740$$

or  $d_c = 27.2 \text{ mm}$

From DDB (coarse series), we find that the standard core diameter of the bolt is 28.706 mm and the corresponding size of the bolt is M 33. **Ans.**

#### **References:**

1. Machine Design - V.Bandari .
2. Machine Design – R.S. Khurmi
3. Design Data hand Book - S MD Jalaludin.



**Eccentric Load Acting Perpendicular to the Axis of Bolts**

A wall bracket carrying an eccentric load perpendicular to the axis of the bolts is shown in Fig.2.

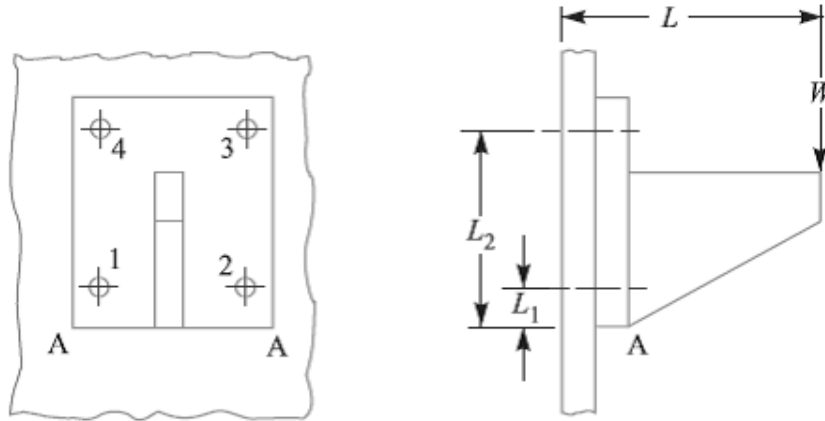

Fig. 2. Eccentric load perpendicular to the axis of bolts.

In this case, the bolts are subjected to direct shearing load which is equally shared by all the bolts. Therefore direct shear load on each bolts,

$$W_s = W/n, \text{ where } n \text{ is number of bolts.}$$

A little consideration will show that the eccentric load  $W$  will try to tilt the bracket in the clockwise direction about the edge  $A-A$ . As discussed earlier, the bolts will be subjected to tensile stress due to the turning moment. The maximum tensile load on a heavily loaded bolt ( $W_t$ ) may be obtained in the similar manner as discussed in the previous article. In this case, bolts 3 and 4 are heavily loaded.

Maximum tensile load on bolt 3 or 4,

$$W_{t2} = W_t = \frac{W.L.L_2}{2 [(L_1)^2 + (L_2)^2]}$$

When the bolts are subjected to shear as well as tensile loads, then the equivalent loads may be determined by the following relations:

Equivalent tensile load,

$$W_{te} = \frac{1}{2} \left[ W_t + \sqrt{(W_t)^2 + 4(W_s)^2} \right]$$

And equivalent shear load,

$$W_{se} = \frac{1}{2} \left[ \sqrt{(W_t)^2 + 4(W_s)^2} \right]$$

Knowing the value of equivalent loads, the size of the bolt may be determined for the given allowable stresses.

Problem:

For supporting the travelling crane in a workshop, the brackets are fixed on steel columns as shown in Fig. The maximum load that comes on the bracket is 12 kN acting vertically at a distance of 400 mm from the face of the column. The vertical face of the bracket is secured to a column by four bolts, in two rows (two in each row) at a distance of 50 mm from the lower edge of the bracket. Determine the size of the bolts if the permissible value of the tensile stress for the bolt material is 84 MPa. Also find the cross-section of the arm of the bracket which is rectangular.

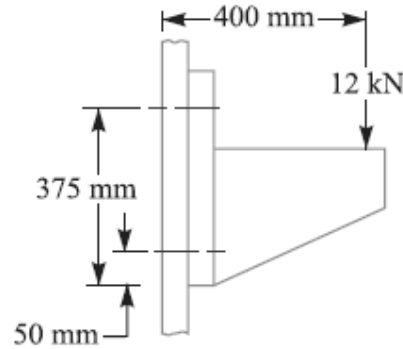

**Solution.** Given :  $W = 12 \text{ kN} = 12 \times 10^3 \text{ N}$  ;  $L = 400 \text{ mm}$  ;  
 $L_1 = 50 \text{ mm}$  ;  $L_2 = 375 \text{ mm}$  ;  $\sigma_t = 84 \text{ MPa} = 84 \text{ N/mm}^2$  ;  $n = 4$

We know that direct shear load on each bolt,

$$W_s = \frac{W}{n} = \frac{12}{4} = 3 \text{ kN}$$

Since the load  $W$  will try to tilt the bracket in the clockwise direction about the lower edge, therefore the bolts will be subjected to tensile load due to turning moment. The maximum loaded bolts are 3 and 4 (See Fig.1), because they lie at the greatest distance from the tilting edge A-A (*i.e.* lower edge).

We know that maximum tensile load carried by bolts 3 and 4,

$$W_t = \frac{W.L.L_2}{2[(L_1)^2 + (L_2)^2]} = \frac{12 \times 400 \times 375}{2[(50)^2 + (375)^2]} = 6.29 \text{ kN}$$

Since the bolts are subjected to shear load as well as tensile load, therefore equivalent tensile load,

$$W_{te} = \frac{1}{2} \left[ W_t + \sqrt{(W_t)^2 + 4(W_s)^2} \right] = \frac{1}{2} \left[ 6.29 + \sqrt{(6.29)^2 + 4 \times 3^2} \right] \text{ kN}$$

$$= \frac{1}{2} (6.29 + 8.69) = 7.49 \text{ kN} = 7490 \text{ N}$$



*Size of the bolt*

Let  $d_c$  = Core diameter of the bolt.

We know that the equivalent tensile load ( $W_{te}$ ),

$$7490 = \frac{\pi}{4} (d_c)^2 \sigma_t = \frac{\pi}{4} (d_c)^2 84 = 66 (d_c)^2$$

$$\therefore (d_c)^2 = 7490 / 66 = 113.5 \quad \text{or} \quad d_c = 10.65 \text{ mm}$$

From Table 11.1 (coarse series), the standard core diameter is 11.546 mm and the corresponding size of the bolt is M 14. **Ans.**

*Cross-section of the arm of the bracket*

Let  $t$  and  $b$  = Thickness and depth of arm of the bracket respectively.

$\therefore$  Section modulus,

$$Z = \frac{1}{6} t b^2$$

Assume that the arm of the bracket extends upto the face of the steel column. This assumption gives stronger section for the arm of the bracket.

$\therefore$  Maximum bending moment on the bracket,

$$M = 12 \times 10^3 \times 400 = 4.8 \times 10^6 \text{ N-mm}$$

We know that the bending (tensile) stress ( $\sigma_t$ ),

$$84 = \frac{M}{Z} = \frac{4.8 \times 10^6 \times 6}{t b^2} = \frac{28.8 \times 10^6}{t b^2}$$

$$\therefore t b^2 = 28.8 \times 10^6 / 84 = 343 \times 10^3 \quad \text{or} \quad t = 343 \times 10^3 / b^2$$

Assuming depth of arm of the bracket,  $b = 250$  mm, we have

$$t = 343 \times 10^3 / (250)^2 = 5.5 \text{ mm Ans.}$$

**References:**

1. Machine Design - V. Bandari .
2. Machine Design – R.S. Khurmi
3. Design Data hand Book - S MD Jalaludin.



**Eccentric Load on a Bracket with Circular Base**

Sometimes the base of a bracket is made circular as in case of a flanged bearing of a heavy machine tool and pillar crane etc. Consider a round flange bearing of a machine tool having four bolts as shown in Fig. 1.

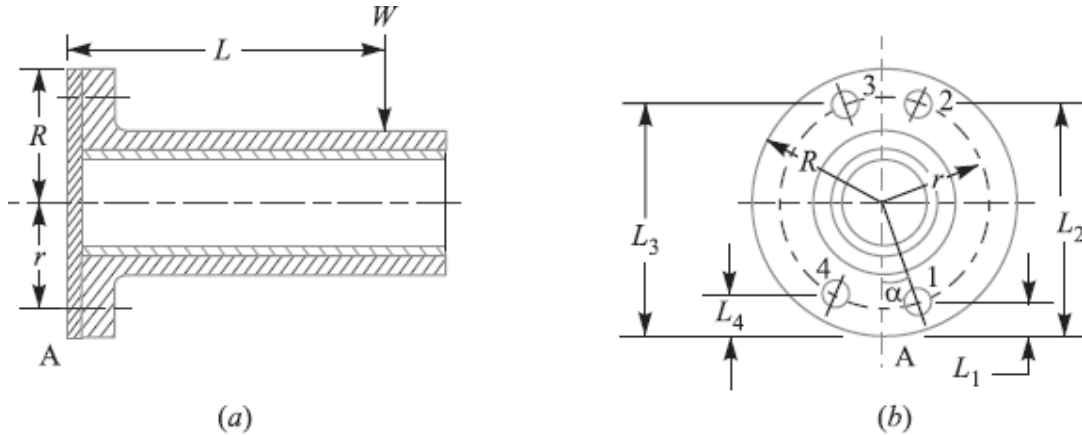

Fig.1. Eccentric load on a bracket with circular base.

- Let  $R$  = Radius of the column flange,
- $r$  = Radius of the bolt pitch circle,
- $w$  = Load per bolt per unit distance from the tilting edge,
- $L$  = Distance of the load from the tilting edge, and
- $L_1, L_2, L_3,$  and  $L_4$  = Distance of bolt centers from the tilting edge  $A$ .

As discussed in the previous article, equating the external moment  $W \times L$  to the sum of the resisting moments of all the bolts, we have

$$W.L = w [(L_1)^2 + (L_2)^2 + (L_3)^2 + (L_4)^2] \tag{i}$$

$$w = \frac{W.L}{(L_1)^2 + (L_2)^2 + (L_3)^2 + (L_4)^2}$$

Now from the geometry of the Fig. 1(b), we find that

$$L_1 = R - r \cos \alpha \quad L_2 = R + r \sin \alpha$$

$$L_3 = R + r \cos \alpha \quad \text{and} \quad L_4 = R - r \sin \alpha$$

Substituting these values in equation (i), we get

$$w = \frac{W.L}{4 R^2 + 2 r^2}$$

Load in the bolt situated at 1 =  $w.L_1$  =

$$\frac{W.L.L_1}{4 R^2 + 2 r^2} = \frac{W.L(R - r \cos \alpha)}{4 R^2 + 2 r^2}$$

This load will be maximum when  $\cos \alpha$  is minimum *i.e.* when  $\cos \alpha = -1$  or  $\alpha = 180^\circ$ .

Maximum load in a bolt

$$= \frac{W.L(R+r)}{4R^2+2r^2}$$

In general, if there are  $n$  number of bolts, then load in a bolt

$$= \frac{2W.L(R-r\cos\alpha)}{n(2R^2+r^2)}$$

And maximum load in a bolt,

$$W_t = \frac{2W.L(R+r)}{n(2R^2+r^2)}$$

The above relation is used when the direction of the load  $W$  changes with relation to the bolts as in the case of pillar crane. But if the direction of load is fixed, then the maximum load on the bolts may be reduced by locating the bolts in such a way that two of them are equally stressed as shown in Fig.2. In such a case, maximum load is given by

$$W_t = \frac{2W.L}{n} \left[ \frac{R+r\cos\left(\frac{180}{n}\right)}{2R^2+r^2} \right]$$

Knowing the value of maximum load, we can determine the size of the bolt.

**Note:** Generally, two dowel pins as shown in Fig. 2, are used to take up the shear load. Thus the bolts are relieved of shear stress and the bolts are designed for tensile load only.

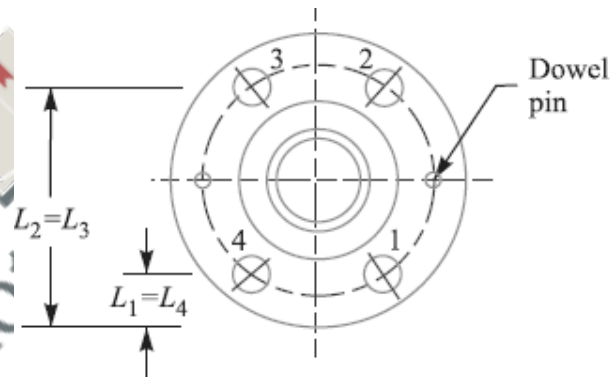

Fig.2.

Problem:

A flanged bearing, as shown in Fig.1, is fastened to a frame by means of four bolts spaced equally on 500 mm bolt circle. The diameter of bearing flange is 650 mm and a load of 400 kN acts at a distance of 250 mm from the frame. Determine the size of the bolts, taking safe tensile stress as 60 MPa for the material of the bolts.

**Solution.** Given :  $n = 4$  ;  $d = 500$  mm or  $r = 250$  mm ;  $D = 650$  mm or  $R = 325$  mm ;  $W = 400$  kN =  $400 \times 10^3$  N ;  $L = 250$  mm ;  $\sigma_t = 60$  MPa =  $60$  N/mm<sup>2</sup>

Let  $d_c$  = Core diameter of the bolts.

We know that when the bolts are equally spaced, the maximum load on the bolt,

$$W_t = \frac{2WL}{n} \left[ \frac{R + r \cos\left(\frac{180}{n}\right)}{2R^2 + r^2} \right]$$

$$= \frac{2 \times 400 \times 10^3 \times 250}{4} \left[ \frac{325 + 250 \cos\left(\frac{180}{4}\right)}{2(325)^2 + (250)^2} \right] = 91\,643 \text{ N}$$

We also know that maximum load on the bolt ( $W_t$ ),

$$91\,643 = \frac{\pi}{4} (d_c)^2 \sigma_t = \frac{\pi}{4} (d_c)^2 60 = 47.13 (d_c)^2$$

$$\therefore (d_c)^2 = 91\,643 / 47.13 = 1945 \quad \text{or} \quad d_c = 44 \text{ mm}$$

From DDB, we find that the standard core diameter of the bolt is 45.795 mm and corresponding size of the bolt is M 52. **Ans.**

**References:**

1. Machine Design - V.Bandari .
2. Machine Design – R.S. Khurmi
3. Design Data hand Book - S MD Jalaludin.



**Eccentric Load Acting in the Plane Containing the Bolts**

When the eccentric load acts in the plane containing the bolts, as shown in Fig.1, then the same procedure may be followed as discussed for eccentric loaded riveted joints.

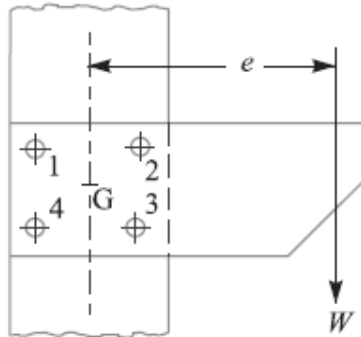

Fig. 1. Eccentric load in the plane containing the bolts.

Problem:

Fig.2 shows a solid forged bracket to carry a vertical load of 13.5 kN applied through the centre of hole. The square flange is secured to the flat side of a vertical stanchion through four bolts. Calculate suitable diameter  $D$  and  $d$  for the arms of the bracket, if the permissible stresses are 110 MPa in tension and 65 MPa in shear. Estimate also the tensile load on each top bolt and the maximum shearing force on each bolt.

**Solution.** Given :  $W = 13.5 \text{ kN} = 13\,500 \text{ N}$ ;  $\sigma_t = 110 \text{ MPa} = 110 \text{ N/mm}^2$ ;  $\tau = 65 \text{ MPa} = 65 \text{ N/mm}^2$

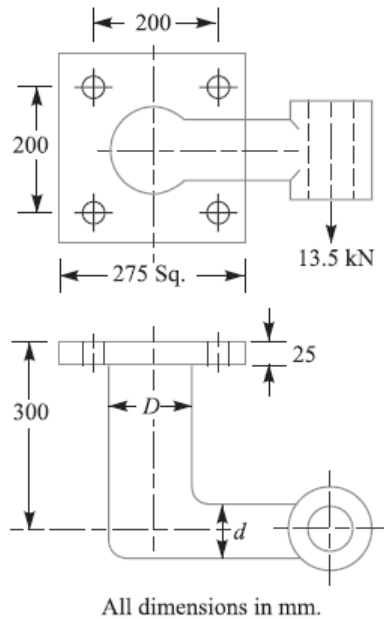

Fig.2

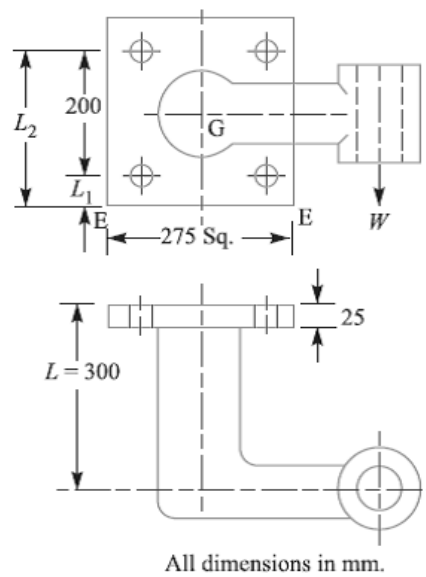

Fig.3

*Diameter D for the arm of the bracket*

The section of the arm having  $D$  as the diameter is subjected to bending moment as well as twisting moment. We know that bending moment,

$$M = 13\,500 \times (300 - 25) = 3712.5 \times 10^3 \text{ N-mm}$$

and twisting moment,  $T = 13\,500 \times 250 = 3375 \times 10^3 \text{ N-mm}$

∴ Equivalent twisting moment,

$$\begin{aligned} T_e &= \sqrt{M^2 + T^2} = \sqrt{(3712.5 \times 10^3)^2 + (3375 \times 10^3)^2} \text{ N-mm} \\ &= 5017 \times 10^3 \text{ N-mm} \end{aligned}$$

We know that equivalent twisting moment ( $T_e$ ),

$$5017 \times 10^3 = \frac{\pi}{16} \times \tau \times D^3 = \frac{\pi}{16} \times 65 \times D^3 = 12.76 D^3$$

$$\therefore D^3 = 5017 \times 10^3 / 12.76 = 393 \times 10^3$$

or  $D = 73.24$  say **75 mm Ans.**

*Diameter (d) for the arm of the bracket*

The section of the arm having  $d$  as the diameter is subjected to bending moment only. We know that bending moment,

$$M = 13\,500 \left( 250 - \frac{75}{2} \right) = 2868.8 \times 10^3 \text{ N-mm}$$

and section modulus,  $Z = \frac{\pi}{32} \times d^3 = 0.0982 d^3$

We know that bending (tensile) stress ( $\sigma_t$ ),

$$110 = \frac{M}{Z} = \frac{2868.8 \times 10^3}{0.0982 d^3} = \frac{29.2 \times 10^6}{d^3}$$

$$\therefore d^3 = 29.2 \times 10^6 / 110 = 265.5 \times 10^3 \quad \text{or} \quad d = 64.3 \text{ say } 65 \text{ mm Ans.}$$

*Tensile load on each top bolt*

Due to the eccentric load  $W$ , the bracket has a tendency to tilt about the edge  $E-E$ , as shown in Fig. 11.46.

Let  $w$  = Load on each bolt per mm distance from the tilting edge due to the tilting effect of the bracket.

Since there are two bolts each at distance  $L_1$  and  $L_2$  as shown in Fig. 11.46, therefore total moment of the load on the bolts about the tilting edge  $E-E$

$$\begin{aligned} &= 2(wL_1)L_1 + 2(wL_2)L_2 = 2w[(L_1)^2 + (L_2)^2] \\ &= 2w[(37.5)^2 + (237.5)^2] = 115\,625 w \text{ N-mm} \end{aligned} \quad \dots(i)$$

$$\dots(\because L_1 = 37.5 \text{ mm and } L_2 = 237.5 \text{ mm})$$

and turning moment of the load about the tilting edge

$$= WL = 13\,500 \times 300 = 4050 \times 10^3 \text{ N-mm} \quad \dots(ii)$$

From equations (i) and (ii), we have

$$w = 4050 \times 10^3 / 115\,625 = 35.03 \text{ N/mm}$$

∴ Tensile load on each top bolt

$$= wL_2 = 35.03 \times 237.5 = 8320 \text{ N Ans.}$$

**Maximum shearing force on each bolt**

We know that primary shear load on each bolt acting vertically downwards,

$$W_{s1} = \frac{W}{n} = \frac{13\,500}{4} = 3375 \text{ N} \quad \dots(\because \text{No. of bolts, } n = 4)$$

Since all the bolts are at equal distances from the centre of gravity of the four bolts (G), therefore the secondary shear load on each bolt is same.

Distance of each bolt from the centre of gravity (G) of the bolts,

$$l_1 = l_2 = l_3 = l_4 = \sqrt{(100)^2 + (100)^2} = 141.4 \text{ mm}$$

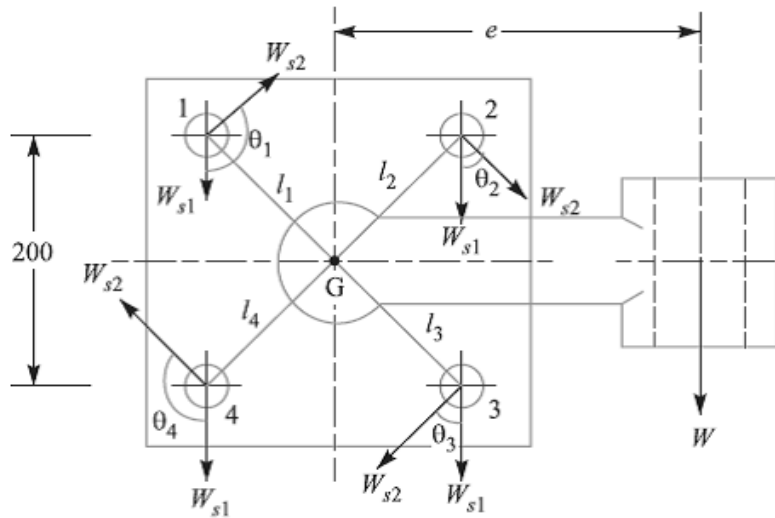

Fig 4

∴ Secondary shear load on each bolt,

$$W_{s2} = \frac{W \cdot e \cdot l_1}{(l_1)^2 + (l_2)^2 + (l_3)^2 + (l_4)^2} = \frac{13\,500 \times 250 \times 141.4}{4 (141.4)^2} = 5967 \text{ N}$$

Since the secondary shear load acts at right angles to the line joining the centre of gravity of the bolt group to the centre of the bolt as shown in Fig. 4, therefore the resultant of the primary and secondary shear load on each bolt gives the maximum shearing force on each bolt. From the geometry of the Fig. 4, we find that

$$\theta_1 = \theta_4 = 135^\circ, \text{ and } \theta_2 = \theta_3 = 45^\circ$$

Maximum shearing force on the bolts 1 and 4

$$\begin{aligned} &= \sqrt{(W_{s1})^2 + (W_{s2})^2 + 2 W_{s1} \times W_{s2} \times \cos 135^\circ} \\ &= \sqrt{(3375)^2 + (5967)^2 - 2 \times 3375 \times 5967 \times 0.7071} = 4303 \text{ N Ans.} \end{aligned}$$

And maximum shearing force on the bolts 2 and 3



$$= \sqrt{(W_{s1})^2 + (W_{s2})^2 + 2 W_{s1} \times W_{s2} \times \cos 45^\circ}$$

$$= \sqrt{(3375)^2 + (5967)^2 + 2 \times 3375 \times 5967 \times 0.7071} = 8687 \text{ N Ans.}$$

**References:**

1. Machine Design - V.Bandari .
2. Machine Design – R.S. Khurmi
3. Design Data hand Book - S MD Jalaludin.



**Introduction**

A key is a piece of mild steel inserted between the shaft and hub or boss of the pulley to connect these together in order to prevent relative motion between them. It is always inserted parallel to the axis of the shaft. Keys are used as temporary fastenings and are subjected to considerable crushing and shearing stresses. A keyway is a slot or recess in a shaft and hub of the pulley to accommodate a key.

**Types of Keys**

The following types of keys are important from the subject point of view :

1. Sunk keys, 2. Saddle keys, 3. Tangent keys, 4. Round keys, and 5. Splines.

**Sunk Keys**

The sunk keys are provided half in the keyway of the shaft and half in the keyway of the hub or boss of the pulley. The sunk keys are of the following types :

**1. Rectangular sunk key.** A rectangular sunk key is shown in Fig. The usual proportions of this key are :

Width of key,  $w = d / 4$  ; and thickness of key,  $t = 2w / 3 = d / 6$

where  $d$  = Diameter of the shaft or diameter of the hole in the hub.

The key has taper 1 in 100 on the top side only.

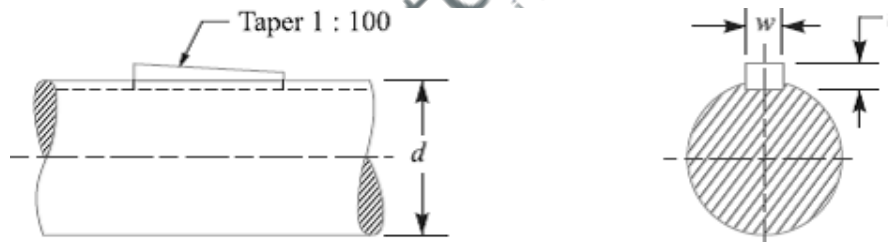

Fig. Sunk Key

**2. Square sunk key.** The only difference between a rectangular sunk key and a square sunk key is that its width and thickness are equal, i.e.  $w = t = d / 4$

**3. Parallel sunk key.** The parallel sunk keys may be of rectangular or square section uniform in width and thickness throughout. It may be noted that a parallel key is a taper less and is used where the pulley, gear or other mating piece is required to slide along the shaft.

**4. Gib-head key.** It is a rectangular sunk key with a head at one end known as **gib head**.

It is usually provided to facilitate the removal of key. A gib head key is shown in Fig.

(a) and its use is shown in Fig. (b).

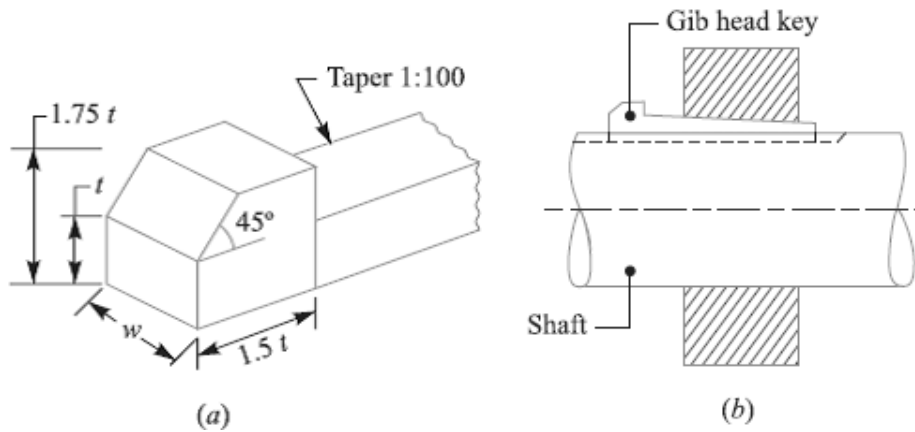

Fig. Gib head key and its use.

The usual proportions of the gib head key are:

Width,  $w = d / 4$  ; and thickness at large end,  $t = 2w / 3 = d / 6$

**5. Feather key.** A key attached to one member of a pair and which permits relative axial movement is known as **feather key**. It is a special type of parallel key which transmits a turning moment and also permits axial movement. It is fastened either to the shaft or hub, the key being a sliding fit in the key way of the moving piece.

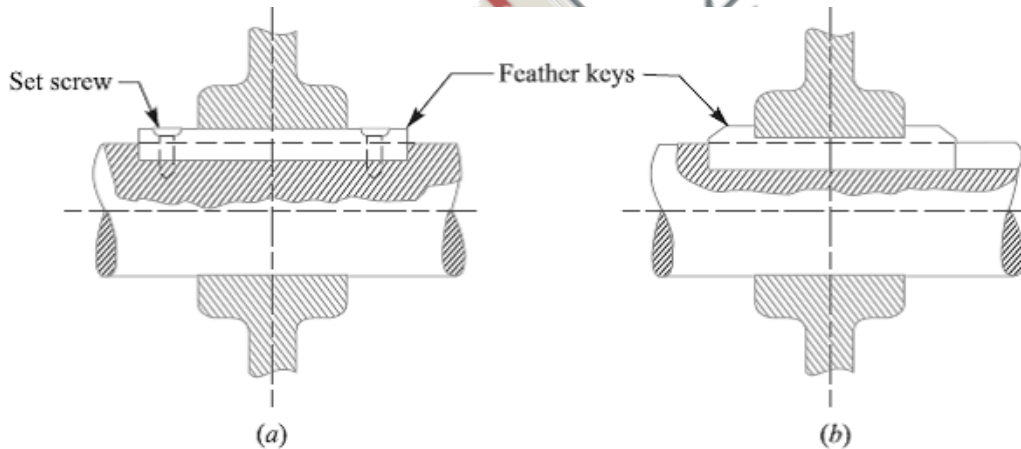

Fig. Feather Keys

**6. Woodruff key.** The woodruff key is an easily adjustable key. It is a piece from a cylindrical disc having segmental cross-section in front view as shown in Fig. A woodruff key is capable of tilting in a recess milled out in the shaft by a cutter having the same curvature as the disc from which the key is made. This key is largely used in machine tool and automobile construction.

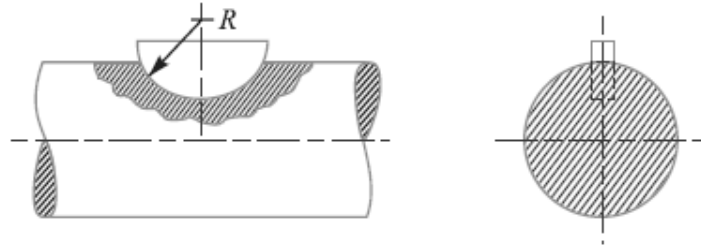

Fig. Woodruff Key

The main advantages of a woodruff key are as follows:

1. It accommodates itself to any taper in the hub or boss of the mating piece.
2. It is useful on tapering shaft ends. Its extra depth in the shaft prevents any tendency to turn over in its keyway.

The disadvantages are:

1. The depth of the keyway weakens the shaft.
2. It can not be used as a feather.

**Saddle keys**

The saddle keys are of the following two types:

1. Flat saddle key, and 2. Hollow saddle key.

A **flat saddle key** is a taper key which fits in a keyway in the hub and is flat on the shaft as shown in Fig. It is likely to slip round the shaft under load. Therefore it is used for comparatively light loads.

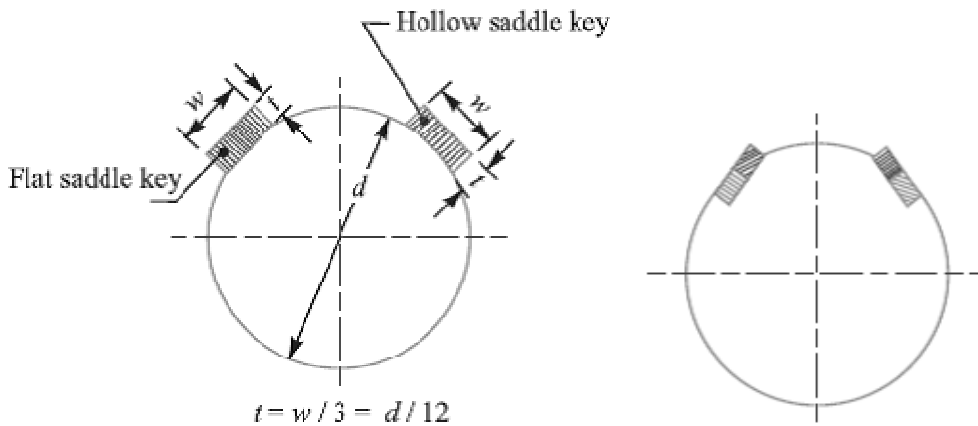

Fig. Flat saddle key and Tangent keys

A **hollow saddle key** is a taper key which fits in a keyway in the hub and the bottom of the key is shaped to fit the curved surface of the shaft. Since hollow saddle keys hold on by friction, therefore these are suitable for light loads. It is usually used as a temporary fastening in fixing and setting eccentrics, cams etc.

**Tangent Keys**

The tangent keys are fitted in pair at right angles as shown in Fig. Each key is to withstand torsion in one direction only. These are used in large heavy duty shafts.

**Round Keys**

The round keys, as shown in Fig. (a) are circular in section and fit into holes drilled partly in the shaft and partly in the hub. They have the advantage that their keyways may be drilled and reamed after the mating parts have been assembled. Round keys are usually considered to be most appropriate for low power drives.

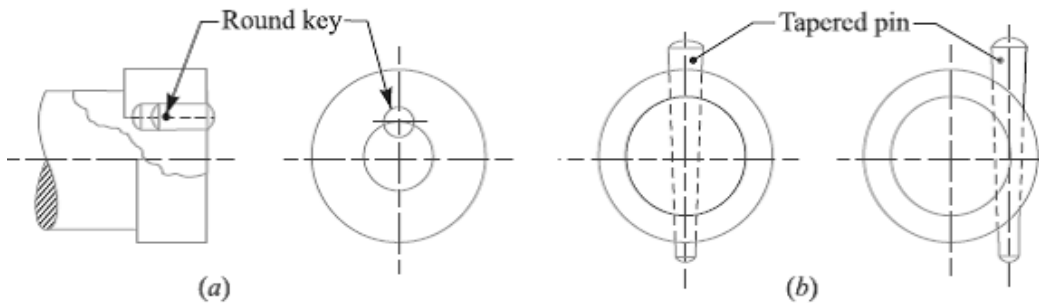

**Splines**

Sometimes, keys are made integral with the shaft which fits the keyways broached in the hub. Such shafts are known as **splined shafts** as shown in Fig. These shafts usually have six, ten or sixteen splines. The splined shafts are relatively stronger than shafts having a single keyway.

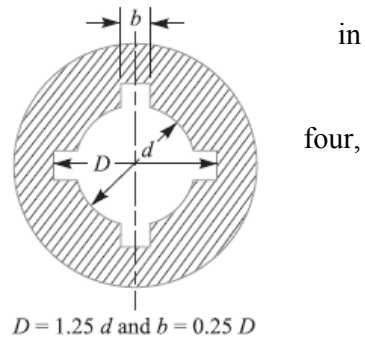

**Stresses in Keys:**

**Forces acting on a Sunk Key**

When a key is used in transmitting torque from a shaft to a rotor or hub, the following two types of forces act on the key:

1. Forces (F1) due to fit of the key in its keyway, as in a tight fitting straight key or in a tapered key driven in place. These forces produce compressive stresses in the key which are difficult to determine in magnitude.
2. Forces (F) due to the torque transmitted by the shaft. These forces produce shearing and compressive (or crushing) stresses in the key.

The forces acting on a key for a clockwise torque being transmitted from a shaft to a hub are shown in Fig.

In designing a key, forces due to fit of the key are neglected and it is assumed that the distribution of forces along the length of key is uniform.

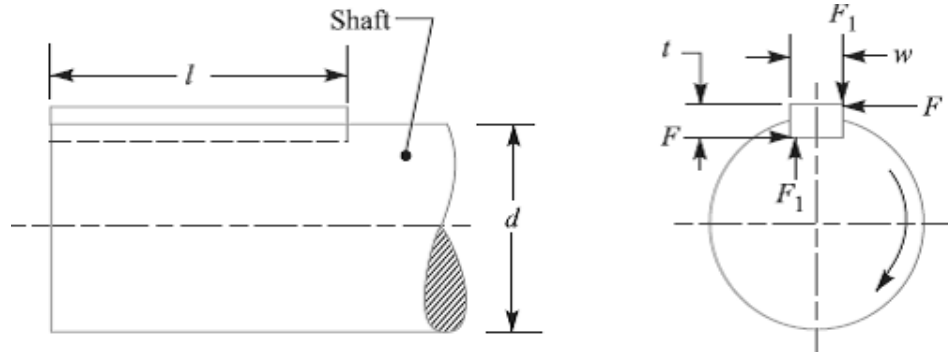

**Strength of a Sunk Key**

A key connecting the shaft and hub is shown in Fig.

Let  $T$  = Torque transmitted by the shaft,

$F$  = Tangential force acting at the circumference of the shaft,

$d$  = Diameter of shaft,

$l$  = Length of key,

$w$  = Width of key.

$t$  = Thickness of key, and

$\tau$  and  $\sigma_c$  = Shear and crushing stresses for the material of key.

A little consideration will show that due to the power transmitted by the shaft, the key may fail due to shearing or crushing. Considering shearing of the key, the tangential shearing force acting at the circumference of the shaft,

$$F = \text{Area resisting shearing} \times \text{Shear stress} = l \times w \times \tau$$

Therefore, Torque transmitted by the shaft,

$$T = F \times \frac{d}{2} = l \times w \times \tau \times \frac{d}{2} \quad \dots(i)$$

Considering crushing of the key, the tangential crushing force acting at the circumference of the shaft,

$$F = \text{Area resisting crushing} \times \text{Crushing stress}$$

$$= l \times \frac{t}{2} \times \sigma_c$$

Therefore, Torque transmitted by the shaft,

$$T = F \times \frac{d}{2} = l \times \frac{t}{2} \times \sigma_c \times \frac{d}{2} \quad \dots(ii)$$

The key is equally strong in shearing and crushing, if

$$l \times w \times \tau \times \frac{d}{2} = l \times \frac{t}{2} \times \sigma_c \times \frac{d}{2}$$

Or

$$\frac{w}{t} = \frac{\sigma_c}{2\tau}$$

The permissible crushing stress for the usual key material is at least twice the permissible shearing stress. Therefore from the above equation, we have  $w = t$ . In other words, a square key is equally strong in shearing and crushing.

In order to find the length of the key to transmit full power of the shaft, the shearing strength of the key is equal to the torsional shear strength of the shaft. We know that the shearing strength of key,

$$T = l \times w \times \tau \times \frac{d}{2}$$

And torsional shear strength of the shaft,

$$T = \frac{\pi}{16} \times \tau_1 \times d^3$$

From the above

$$l \times w \times \tau \times \frac{d}{2} = \frac{\pi}{16} \times \tau_1 \times d^3$$

$$l = \frac{\pi}{8} \times \frac{\tau_1 d^2}{w \times \tau} = \frac{\pi d}{2} \times \frac{\tau_1}{\tau} = 1.571 d \times \frac{\tau_1}{\tau}$$

When the key material is same as that of the shaft, then  $\tau = \tau_1$ . So,  $l = 1.571 d$ .

### References:

1. Machine Design - V. Bandari .
2. Machine Design – R.S. Khurmi
3. Design Data hand Book - S MD Jalaludin.

**Cottered Joints:**

A cotter is a flat wedge shaped piece of rectangular cross-section and its width is tapered (either on one side or both sides) from one end to another for an easy adjustment. The taper varies from 1 in 48 to 1 in 24 and it may be increased up to 1 in 8, if a locking device is provided. The locking device may be a taper pin or a set screw used on the lower end of the cotter. The cotter is usually made of mild steel or wrought iron. A cotter joint is a temporary fastening and is used to connect rigidly two co-axial rods or bars which are subjected to axial tensile or compressive forces. It is usually used in connecting a piston rod to the crosshead of a reciprocating steam engine, a piston rod and its extension as a tail or pump rod, strap end of connecting rod etc.

**Types of Cotter Joints**

Following are the three commonly used cotter joints to connect two rods by a cotter:

1. Socket and spigot cotter joint, 2. Sleeve and cotter joint, and 3. Gib and cotter joint.

**Socket and Spigot Cotter Joint**

In a socket and spigot cotter joint, one end of the rods (say *A*) is provided with a socket type of end as shown in Fig., and the other end of the other rod (say *B*) is inserted into a socket. The end of the rod which goes into a socket is also called *spigot*. A rectangular hole is made in the socket and spigot. A cotter is then driven tightly through a hole in order to make the temporary connection between the two rods. The load is usually acting axially, but it changes its direction and hence the cotter joint must be designed to carry both the tensile and compressive loads. The compressive load is taken up by the collar on the spigot.

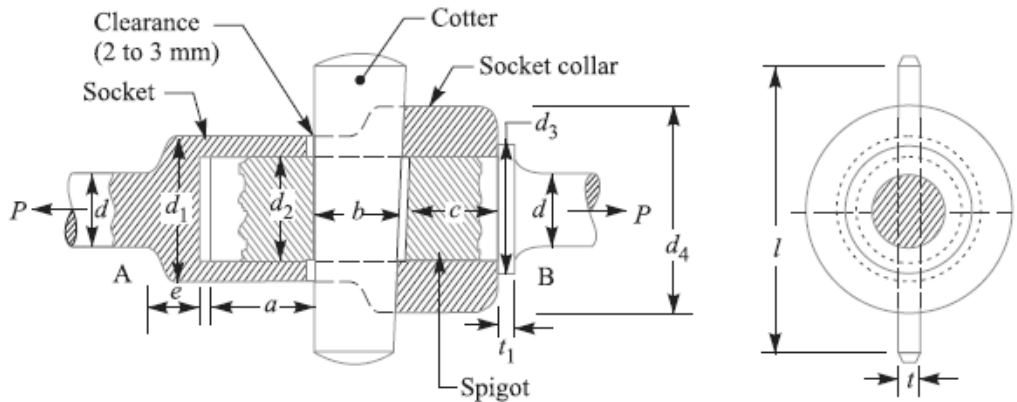

Fig. Socket and spigot cotter joint

**Design of Socket and Spigot Cotter Joint**

The socket and spigot cotter joint is shown in Fig.

Let  $P$  = Load carried by the rods,



- d = Diameter of the rods,
- d<sub>1</sub> = Outside diameter of socket,
- d<sub>2</sub> = Diameter of spigot or inside diameter of socket,
- d<sub>3</sub> = Outside diameter of spigot collar,
- t<sub>1</sub> = Thickness of spigot collar,
- d<sub>4</sub> = Diameter of socket collar,
- c = Thickness of socket collar,
- b = Mean width of cotter,
- t = Thickness of cotter,
- l = Length of cotter,
- a = Distance from the end of the slot to the end of rod,
- σ<sub>t</sub> = Permissible tensile stress for the rods material,
- τ = Permissible shear stress for the cotter material, and
- σ<sub>c</sub> = Permissible crushing stress for the cotter material.

The dimensions for a socket and spigot cotter joint may be obtained by considering the various modes of failure as discussed below:

**1. Failure of the rods in tension**

$$P = \frac{\pi}{4} \times d^2 \times \sigma_t$$

From this equation, diameter of the rods (d) may be determined.

**2. Failure of spigot in tension across the weakest section (or slot)**

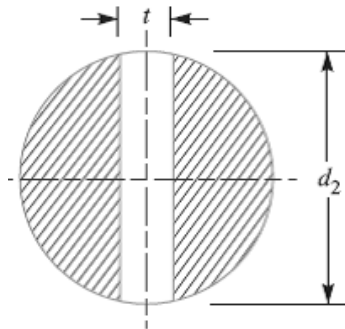

$$P = \left[ \frac{\pi}{4} (d_2)^2 - d_2 \times t \right] \sigma_t$$

From this equation, the diameter of spigot or inside diameter of socket (d<sub>2</sub>) may be determined. In actual practice, the thickness of cotter is usually taken as d<sub>2</sub> / 4.

**3. Failure of the rod or cotter in crushing**

$$P = d_2 \times t \times \sigma_c$$

From this equation, the induced crushing stress may be checked.

**4. Failure of the socket in tension across the slot**

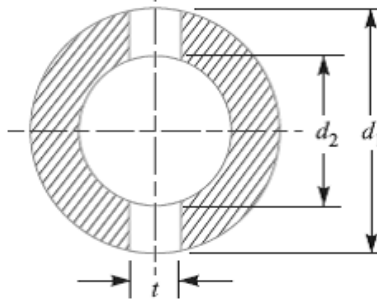

$$P = \left\{ \frac{\pi}{4} [(d_1)^2 - (d_2)^2] - (d_1 - d_2) t \right\} \sigma_t$$

From this equation, outside diameter of socket ( $d_1$ ) may be determined.

**5. Failure of cotter in shear**

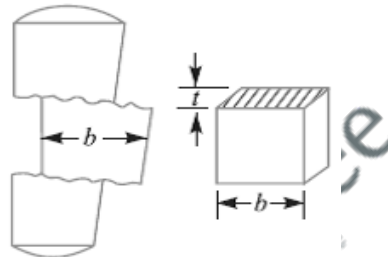

$$P = 2 b \times t \times \tau$$

From this equation, width of cotter ( $b$ ) is determined.

**6. Failure of the socket collar in crushing**

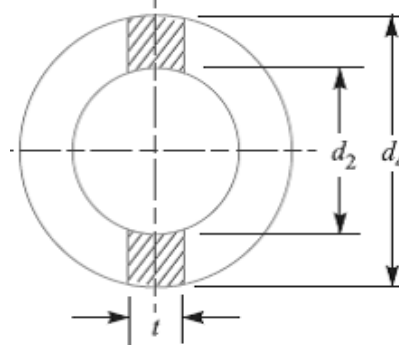

$$P = (d_4 - d_2) t \times \sigma_c$$

From this equation, the diameter of socket collar ( $d_4$ ) may be obtained.

**7. Failure of socket end in shearing**

$$P = 2 (d_4 - d_2) c \times \tau$$

From this equation, the thickness of socket collar ( $c$ ) may be obtained.

**8. Failure of rod end in shear**

$$P = 2 a \times d_2 \times \tau$$

From this equation, the distance from the end of the slot to the end of the rod (a) may be obtained.

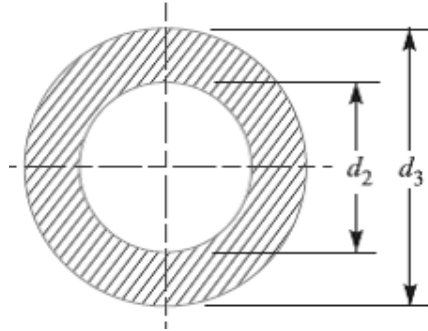
**9. Failure of spigot collar in crushing**

$$P = \frac{\pi}{4} [(d_3)^2 - (d_2)^2] \sigma_c$$

From this equation, the diameter of the spigot collar ( $d_3$ ) may be obtained.

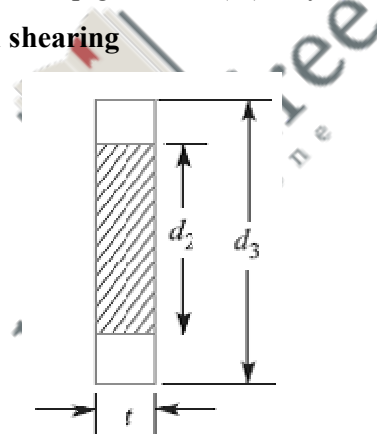
**10. Failure of the spigot collar in shearing**

$$P = \pi d_2 \times t_1 \times \tau$$

From this equation, the thickness of spigot collar ( $t_1$ ) may be obtained.

**11. Failure of cotter in bending**

The maximum bending moment occurs at the centre of the cotter and is given by

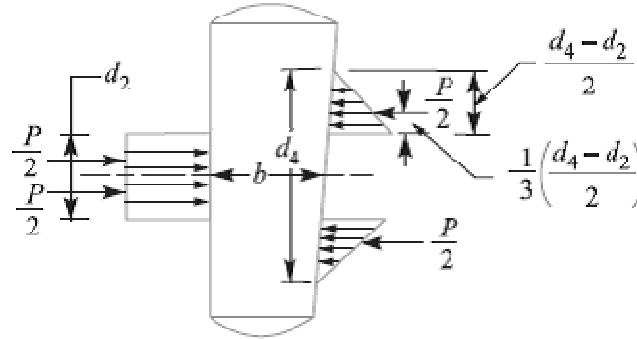

$$M_{max} = \frac{P}{2} \left( \frac{1}{3} \times \frac{d_4 - d_2}{2} + \frac{d_2}{2} \right) - \frac{P}{2} \times \frac{d_2}{4}$$

$$= \frac{P}{2} \left( \frac{d_4 - d_2}{6} + \frac{d_2}{2} - \frac{d_2}{4} \right) = \frac{P}{2} \left( \frac{d_4 - d_2}{6} + \frac{d_2}{4} \right)$$

We know that section modulus of the cotter,

$$Z = t \times b^2 / 6$$

Bending stress induced in the cotter,

$$\sigma_b = \frac{M_{max}}{Z} = \frac{\frac{P}{2} \left( \frac{d_4 - d_2}{6} + \frac{d_2}{4} \right)}{t \times b^2 / 6} = \frac{P (d_4 + 0.5 d_2)}{2 t \times b^2}$$

This bending stress induced in the cotter should be less than the allowable bending stress of the cotter.

12. The length of cotter (l) is taken as 4 d.

13. The taper in cotter should not exceed 1 in 24. In case the greater taper is required, then a locking device must be provided.

14. The draw of cotter is generally taken as 2 to 3 mm.

**Notes: 1.** when all the parts of the joint are made of steel, the following proportions in terms of diameter of the rod (d) are generally adopted:

$d_1 = 1.75 d$  ,  $d_2 = 1.21 d$  ,  $d_3 = 1.5 d$  ,  $d_4 = 2.4 d$  ,  $a = c = 0.75 d$  ,  $b = 1.3 d$  ,  $l = 4 d$  ,  $t = 0.31 d$  ,  $t_1 = 0.45 d$  ,  $e = 1.2 d$ .

Taper of cotter = 1 in 25, and draw of cotter = 2 to 3 mm.

2. If the rod and cotter are made of steel or wrought iron, then  $\tau = 0.8 \sigma_t$  and  $\sigma_c = 2 \sigma_t$  may be taken.

**References:**

1. Machine Design - V.Bandari .
2. Machine Design – R.S. Khurmi
3. Design Data hand Book - S MD Jalaludin.

Problem:

Design and draw a cotter joint to support a load varying from 30 kN in compression to 30 kN in tension. The material used is carbon steel for which the following allowable stresses may be used. The load is applied statically. Tensile stress = compressive stress = 50 MPa ; shear stress = 35 MPa and crushing stress = 90 MPa.

**Solution. Given :**  $P = 30 \text{ kN} = 30 \times 10^3 \text{ N}$ ;  $\sigma_t = 50 \text{ MPa} = 50 \text{ N/mm}^2$ ;  $\tau = 35 \text{ MPa} = 35 \text{ N/mm}^2$ ;  $\sigma_c = 90 \text{ MPa} = 90 \text{ N/mm}^2$

1. Diameter of the rods

Let  $d =$  Diameter of the rods.

Considering the failure of the rod in tension. We know that load ( $P$ ),

$$30 \times 10^3 = \frac{\pi}{4} \times d^2 \times \sigma_t = \frac{\pi}{4} \times d^2 \times 50 = 39.3 d^2$$

$$\therefore d^2 = 30 \times 10^3 / 39.3 = 763 \text{ or } d = 27.6 \text{ say } 28 \text{ mm Ans.}$$

2. Diameter of spigot and thickness of cotter

Let  $d_2 =$  Diameter of spigot or inside diameter of socket, and

$t =$  Thickness of cotter. It may be taken as  $d_2 / 4$ .

Considering the failure of spigot in tension across the weakest section. We know that load ( $P$ ),

$$30 \times 10^3 = \left[ \frac{\pi}{4} (d_2)^2 - d_2 \times t \right] \sigma_t = \left[ \frac{\pi}{4} (d_2)^2 - d_2 \times \frac{d_2}{4} \right] 50 = 26.8 (d_2)^2$$

$$\therefore (d_2)^2 = 30 \times 10^3 / 26.8 = 1119.4 \text{ or } d_2 = 33.4 \text{ say } 34 \text{ mm}$$

and thickness of cotter,  $t = \frac{d_2}{4} = \frac{34}{4} = 8.5 \text{ mm}$

Let us now check the induced crushing stress. We know that load ( $P$ ),

$$30 \times 10^3 = d_2 \times t \times \sigma_c = 34 \times 8.5 \times \sigma_c = 289 \sigma_c$$

$$\therefore \sigma_c = 30 \times 10^3 / 289 = 103.8 \text{ N/mm}^2$$

Since this value of  $\sigma_c$  is more than the given value of  $\sigma_c = 90 \text{ N/mm}^2$ , therefore the dimensions  $d_2 = 34 \text{ mm}$  and  $t = 8.5 \text{ mm}$  are not safe. Now let us find the values of  $d_2$  and  $t$  by substituting the value of  $\sigma_c = 90 \text{ N/mm}^2$  in the above expression, *i.e.*

$$30 \times 10^3 = d_2 \times \frac{d_2}{4} \times 90 = 22.5 (d_2)^2$$

$$\therefore (d_2)^2 = 30 \times 10^3 / 22.5 = 1333 \text{ or } d_2 = 36.5 \text{ say } 40 \text{ mm Ans.}$$

and  $t = d_2 / 4 = 40 / 4 = 10 \text{ mm Ans.}$

3. Outside diameter of socket

Let  $d_1 =$  Outside diameter of socket.

Considering the failure of the socket in tension across the slot. We know that load ( $P$ ),

$$30 \times 10^3 = \left[ \frac{\pi}{4} \{ (d_1)^2 - (d_2)^2 \} - (d_1 - d_2) t \right] \sigma_t$$

$$= \left[ \frac{\pi}{4} \{ (d_1)^2 - (40)^2 \} - (d_1 - 40) 10 \right] 50$$

$$30 \times 10^3 / 50 = 0.7854 (d_1)^2 - 1256.6 - 10 d_1 + 400$$

or  $(d_1)^2 - 12.7d_1 - 1854.6 = 0$

$$\therefore d_1 = \frac{12.7 \pm \sqrt{(12.7)^2 + 4 \times 1854.6}}{2} = \frac{12.7 \pm 87.1}{2}$$

= 49.9 say 50 mm Ans. ...(Taking +ve sign)

4. *Width of cotter*

Let  $b =$  Width of cotter.

Considering the failure of the cotter in shear. Since the cotter is in double shear, therefore load ( $P$ ),

$$30 \times 10^3 = 2b \times t \times \tau = 2b \times 10 \times 35 = 700b$$

$$\therefore b = 30 \times 10^3 / 700 = 43 \text{ mm Ans.}$$

5. *Diameter of socket collar*

Let  $d_4 =$  Diameter of socket collar.

Considering the failure of the socket collar and cotter in crushing. We know that load ( $P$ ),

$$30 \times 10^3 = (d_4 - d_2) t \times \sigma_c = (d_4 - 40) 10 \times 90 = (d_4 - 40) 900$$

$$\therefore d_4 - 40 = 30 \times 10^3 / 900 = 33.3 \text{ or } d_4 = 33.3 + 40 = 73.3 \text{ say } 75 \text{ mm Ans.}$$

6. *Thickness of socket collar*

Let  $c =$  Thickness of socket collar.

Considering the failure of the socket end in shearing. Since the socket end is in double shear, therefore load ( $P$ ),

$$30 \times 10^3 = 2(d_4 - d_2) c \times \tau = 2(75 - 40) c \times 35 = 2450c$$

$$\therefore c = 30 \times 10^3 / 2450 = 12 \text{ mm Ans.}$$

7. *Distance from the end of the slot to the end of the rod*

Let  $a =$  Distance from the end of slot to the end of the rod.

Considering the failure of the rod end in shear. Since the rod end is in double shear, therefore load ( $P$ ),

$$30 \times 10^3 = 2a \times d_2 \times \tau = 2a \times 40 \times 35 = 2800a$$

$$\therefore a = 30 \times 10^3 / 2800 = 10.7 \text{ say } 11 \text{ mm Ans.}$$

8. *Diameter of spigot collar*

Let  $d_3 =$  Diameter of spigot collar.

Considering the failure of spigot collar in crushing. We know that load ( $P$ ),

$$30 \times 10^3 = \frac{\pi}{4} [(d_3)^2 - (d_2)^2] \sigma_c = \frac{\pi}{4} [(d_3)^2 - (40)^2] 90$$

or  $(d_3)^2 - (40)^2 = \frac{30 \times 10^3 \times 4}{90 \times \pi} = 424$

$$\therefore (d_3)^2 = 424 + (40)^2 = 2024 \text{ or } d_3 = 45 \text{ mm Ans.}$$

**9. Thickness of spigot collar**

Let  $t_1$  = Thickness of spigot collar.

Considering the failure of spigot collar in shearing. We know that load ( $P$ ),

$$30 \times 10^3 = \pi d_2 \times t_1 \times \tau = \pi \times 40 \times t_1 \times 35 = 4400 t_1$$

$$\therefore t_1 = 30 \times 10^3 / 4400 = 6.8 \text{ say } 8 \text{ mm Ans.}$$

10. The length of cotter ( $l$ ) is taken as  $4d$ .

$$\therefore l = 4d = 4 \times 28 = 112 \text{ mm Ans.}$$

11. The dimension  $e$  is taken as  $1.2d$ .

$$\therefore e = 1.2 \times 28 = 33.6 \text{ say } 34 \text{ mm Ans.}$$

**References:**

1. Machine Design - V. Bandari .
2. Machine Design – R.S. Khurmi
3. Design Data hand Book - S MD Jalaludin.



**Sleeve and Cotter Joint**

Sometimes, a sleeve and cotter joint as shown in Fig., is used to connect two round rods or bars. In this type of joint, a sleeve or muff is used over the two rods and then two cotters (one on each rod end) are inserted in the holes provided for them in the sleeve and rods. The taper of cotter is usually 1 in 24. It may be noted that the taper sides of the two cotters should face each other as shown in Fig. The clearance is so adjusted that when the cotters are driven in, the two rods come closer to each other thus making the joint tight.

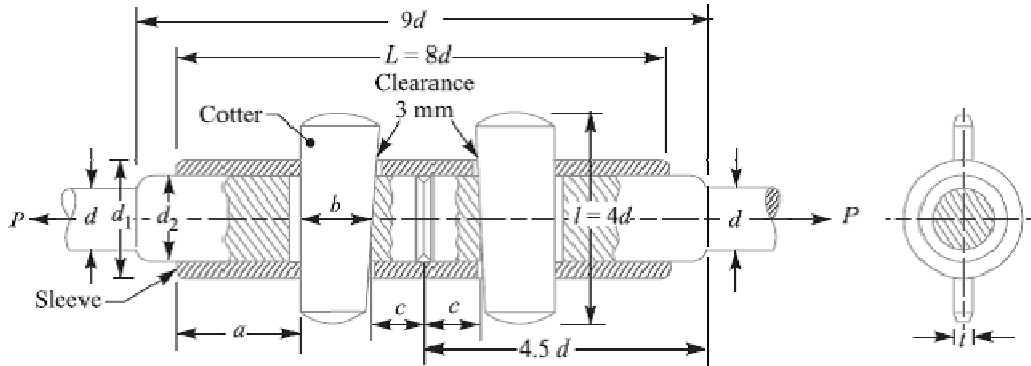

The various proportions for the sleeve and cotter joint in terms of the diameter of rod (d ) are as follows :

Outside diameter of sleeve,

$$d_1 = 2.5 d$$

Diameter of enlarged end of rod,

$$d_2 = \text{Inside diameter of sleeve} = 1.25 d$$

Length of sleeve,  $L = 8 d$

Thickness of cotter,  $t = d_2/4$  or  $0.31 d$

Width of cotter,  $b = 1.25 d$

Length of cotter,  $l = 4 d$

Distance of the rod end (a) from the beginning to the cotter hole (inside the sleeve end) =

Distance of the rod end (c) from its end to the cotter hole =  $1.25 d$

**Design of Sleeve and Cotter Joint**

The sleeve and cotter joint is shown in Fig.

Let  $P$  = Load carried by the rods,

$d$  = Diameter of the rods,

$d_1$  = Outside diameter of sleeve,

$d_2$  = Diameter of the enlarged end of rod,



$t$  = Thickness of cotter,

$l$  = Length of cotter,

$b$  = Width of cotter,

$a$  = Distance of the rod end from the beginning to the cotter hole (inside the sleeve end),

$c$  = Distance of the rod end from its end to the cotter hole,

$\sigma_t$ ,  $\tau$  and  $\sigma_c$  = Permissible tensile, shear and crushing stresses respectively for the material of the rods and cotter.

The dimensions for a sleeve and cotter joint may be obtained by considering the various modes of failure as discussed below:

### 1. Failure of the rods in tension

The rods may fail in tension due to the tensile load  $P$ . We know that

$$P = \frac{\pi}{4} \times d^2 \times \sigma_t$$

From this equation, diameter of the rods ( $d$ ) may be obtained.

### 2. Failure of the rod in tension across the weakest section (i.e. slot)

$$P = \left[ \frac{\pi}{4} (d_2)^2 - d_2 \times t \right] \sigma_t$$

From this equation, the diameter of enlarged end of the rod ( $d_2$ ) may be obtained. The thickness of cotter is usually taken as  $d_2 / 4$ .

### 3. Failure of the rod or cotter in crushing

$$P = d_2 \times t \times \sigma_c$$

From this equation, the induced crushing stress may be checked.

### 4. Failure of sleeve in tension across the slot

$$P = \left[ \frac{\pi}{4} [(d_1)^2 - (d_2)^2] - (d_1 - d_2) t \right] \sigma_t$$

From this equation, the outside diameter of sleeve ( $d_1$ ) may be obtained.

### 5. Failure of cotter in shear

$$P = 2b \times t \times \tau$$

From this equation, width of cotter ( $b$ ) may be determined.

### 6. Failure of rod end in shear

$$P = 2a \times d_2 \times \tau$$

From this equation, distance ( $a$ ) may be determined.

**7. Failure of sleeve end in shear**

$$P = 2 (d_1 - d_2) c \times \tau$$

From this equation, distance (c) may be determined.

**References:**

1. Machine Design - V.Bandari .
2. Machine Design – R.S. Khurmi
3. Design Data hand Book - S MD Jalaludin.



Problem:

Design a sleeve and cotter joint to resist a tensile load of 60 kN. All parts of the joint are made of the same material with the following allowable stresses:  $\sigma_t = 60 \text{ MPa}$  ;  $\tau = 70 \text{ MPa}$  ; and  $\sigma_c = 125 \text{ MPa}$ .

Solution. Given :  $P = 60 \text{ kN} = 60 \times 10^3 \text{ N}$  ;  $\sigma_t = 60 \text{ MPa} = 60 \text{ N/mm}^2$  ;  $\tau = 70 \text{ MPa} = 70 \text{ N/mm}^2$  ;  $\sigma_c = 125 \text{ MPa} = 125 \text{ N/mm}^2$

1. Diameter of the rods

Let  $d =$  Diameter of the rods.

Considering the failure of the rods in tension. We know that load ( $P$ ),

$$60 \times 10^3 = \frac{\pi}{4} \times d^2 \times \sigma_t = \frac{\pi}{4} \times d^2 \times 60 = 47.13 d^2$$

$$\therefore d^2 = 60 \times 10^3 / 47.13 = 1273 \text{ or } d = 35.7 \text{ say } 36 \text{ mm Ans.}$$

2. Diameter of enlarged end of rod and thickness of cotter

Let  $d_2 =$  Diameter of enlarged end of rod, and

$t =$  Thickness of cotter. It may be taken as  $d_2 / 4$ .

Considering the failure of the rod in tension across the weakest section (*i.e.* slot). We know that load ( $P$ ),

$$60 \times 10^3 = \left[ \frac{\pi}{4} (d_2)^2 - d_2 \times t \right] \sigma_t = \left[ \frac{\pi}{4} (d_2)^2 - d_2 \times \frac{d_2}{4} \right] 60 = 32.13 (d_2)^2$$

$$\therefore (d_2)^2 = 60 \times 10^3 / 32.13 = 1867 \text{ or } d_2 = 43.2 \text{ say } 44 \text{ mm Ans.}$$

and thickness of cotter,

$$t = \frac{d_2}{4} = \frac{44}{4} = 11 \text{ mm Ans.}$$

Let us now check the induced crushing stress in the rod or cotter. We know that load ( $P$ ),

$$60 \times 10^3 = d_2 \times t \times \sigma_c = 44 \times 11 \times \sigma_c = 484 \sigma_c$$

$$\therefore \sigma_c = 60 \times 10^3 / 484 = 124 \text{ N/mm}^2$$

Since the induced crushing stress is less than the given value of  $125 \text{ N/mm}^2$ , therefore the dimensions  $d_2$  and  $t$  are within safe limits.

3. Outside diameter of sleeve

Let  $d_1 =$  Outside diameter of sleeve.

Considering the failure of sleeve in tension across the slot. We know that load ( $P$ )

$$\begin{aligned} 60 \times 10^3 &= \left[ \frac{\pi}{4} [(d_1)^2 - (d_2)^2] - (d_1 - d_2) t \right] \sigma_t \\ &= \left[ \frac{\pi}{4} [(d_1)^2 - (44)^2] - (d_1 - 44) 11 \right] 60 \end{aligned}$$

$$\begin{aligned} \therefore 60 \times 10^3 / 60 &= 0.7854 (d_1)^2 - 1520.7 - 11 d_1 + 484 \\ \text{or } (d_1)^2 - 14 d_1 - 2593 &= 0 \\ \therefore d_1 &= \frac{14 \pm \sqrt{(14)^2 + 4 \times 2593}}{2} = \frac{14 \pm 102.8}{2} \\ &= 58.4 \text{ say } 60 \text{ mm Ans.} \end{aligned}$$

**4. Width of cotter**

Let  $b$  = Width of cotter.

Considering the failure of cotter in shear. Since the cotter is in double shear, therefore load ( $P$ ),

$$60 \times 10^3 = 2 b \times t \times \tau = 2 \times b \times 11 \times 70 = 1540 b$$

$$\therefore b = 60 \times 10^3 / 1540 = 38.96 \text{ say } 40 \text{ mm Ans.}$$

**5. Distance of the rod from the beginning to the cotter hole (inside the sleeve end)**

Let  $a$  = Required distance.

Considering the failure of the rod end in shear. Since the rod end is in double shear, therefore load ( $P$ ),

$$60 \times 10^3 = 2 a \times d_2 \times \tau = 2 a \times 44 \times 70 = 6160 a$$

$$\therefore a = 60 \times 10^3 / 6160 = 9.74 \text{ say } 10 \text{ mm Ans.}$$

**6. Distance of the rod end from its end to the cotter hole**

Let  $c$  = Required distance.

Considering the failure of the sleeve end in shear. Since the sleeve end is in double shear, therefore load ( $P$ ),

$$60 \times 10^3 = 2 (d_1 - d_2) c \times \tau = 2 (60 - 44) c \times 70 = 2240 c$$

$$\therefore c = 60 \times 10^3 / 2240 = 26.78 \text{ say } 28 \text{ mm Ans.}$$

**References:**

1. Machine Design - V. Bandari .
2. Machine Design – R.S. Khurmi
3. Design Data hand Book - S MD Jalaludin.

**Gib and Cotter Joint**

This joint is generally used to connect two rods of square or rectangular section. To make the joint; one end of the rod is formed into a U-fork, into which, the end of the other rod fits-in. When a cotter is driven-in, the friction between the cotter and straps of the U-fork, causes the straps open. This is prevented by the use of a gib.

A gib is also a wedge shaped piece of rectangular cross-section with two rectangular projections, called lugs. One side of the gib is tapered and the other straight. The tapered side of the gib bears against the tapered side of the cotter such that the outer edges of the cotter and gib as a unit are parallel. This facilitates making of slots with parallel edges, unlike the tapered edges in case of ordinary cotter joint. The gib also provides larger surface for the cotter to slide on. For making the joint, the gib is placed in position first, and then the cotter is driven-in.

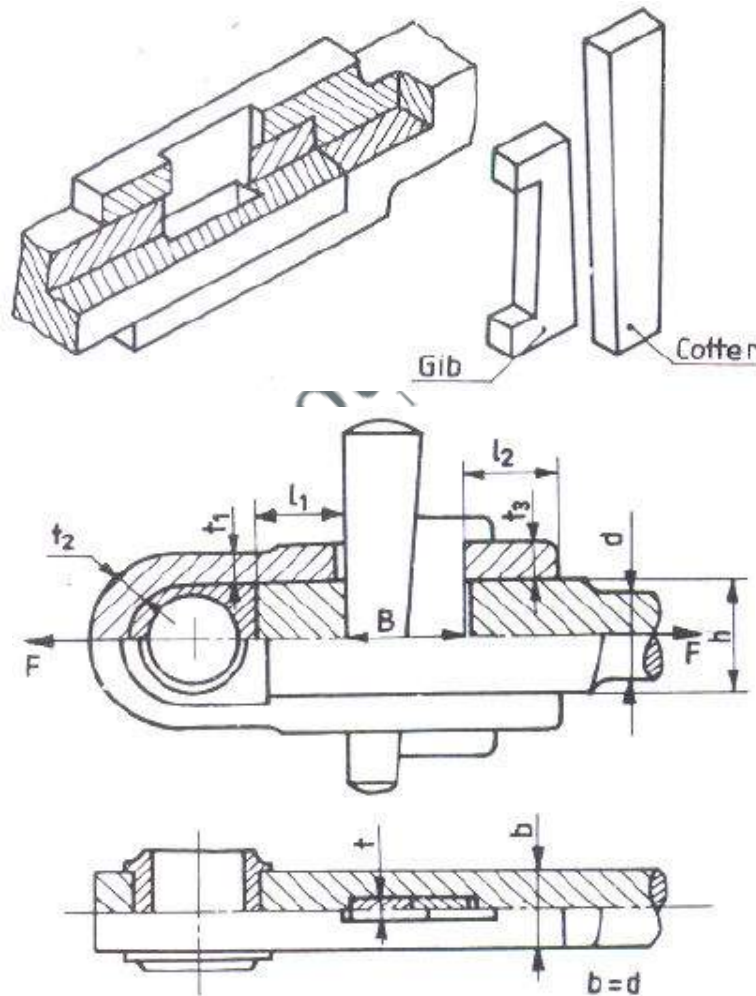

Fig. Gib and cotter Joint

Let  $F$  be the maximum tensile or compressive force in the connecting rod, and

$b$  = width of the strap, which may be taken as equal to the diameter of the rod.  $d$

$h$  = height of the rod end

$t_1$  = thickness of the strap at the thinnest part

$t_2$  = thickness of the strap at the curved portion

$t_3$  = thickness of the strap across the slot

$l_1$  = length of the rod end, beyond the slot

$l_2$  = length of the strap, beyond the slot

$B$  = width of the cotter and gib

$t$  = thickness of the cotter

Let the rod, strap, cotter, and gib are made of the same material with  $\sigma_c$ ,  $\sigma_t$  and  $\tau$  as the permissible stresses. The following are the possible modes of failure, and the corresponding design equations, which may be considered for the design of the joint:

1. Tension failure of the rod across the section of diameter,  $d$

$$F = \frac{\pi d^2}{4} \times \sigma_t$$

2. Tension failure of the rod across the slot (Fig.1)

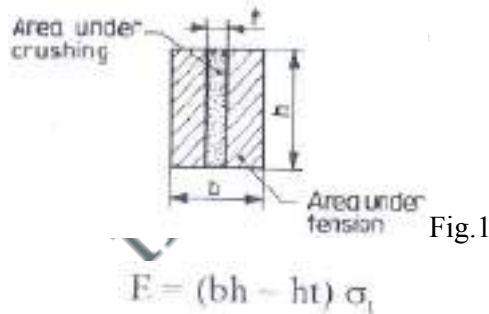

If the rod and strap are made of the same material, and for equality of strength,  $h=2t_3$

3. Tension failure of the strap, across the thinnest part (Fig.2)

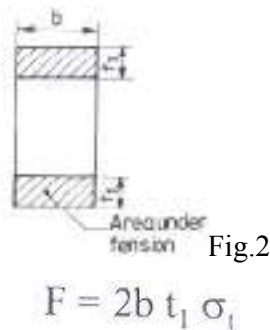

4. Tension failure of the strap across the slot (Fig.3)

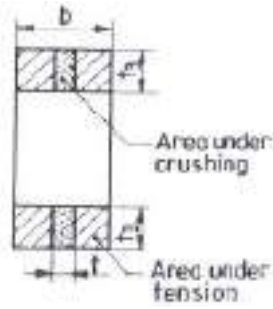

Fig.3

$$F = 2 b t_3 - 2 t t_3 = 2 t_3 (b - t) \sigma_t$$

The thickness,  $t_2$  may be taken as  $(1.15 \text{ to } 1.5) t$ , and

Thickness of the cotter,  $t = b/4$ .

5. Crushing between the rod and cotter (Fig.1)

$$F = h t \sigma_c; \text{ and } h = 2t_3$$

6. Crushing between the strap and gib(Fig.3)

$$F = 2 t t_3 \sigma_c$$

7. Shear failure of the rod end. It is under double shear (Fig.4)

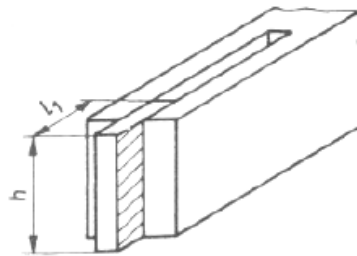

Fig.4

$$F = 2l_1 h \tau$$

8. Shear failure of the strap end. It is under double shear (Fig.5).

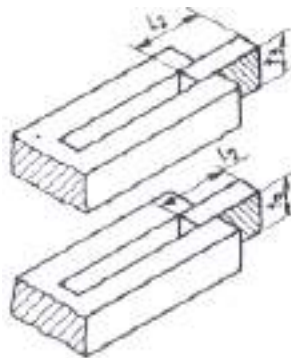

Fig.5

$$F = 4 l_2 t_3 \tau$$

9. Shear failure of the cotter and gib. It is under double shear.

$$F = 2Bt\tau$$

The following proportions for the widths of the cotter and gib may be followed:

Width of the cotter = 0.45 B

Width of the gib = 0.55 B

The above equations may be solved, keeping in mind about the various relations and proportions suggested.

**Problem:**

Design a cotter joint to connect piston rod to the crosshead of a double acting steam engine. The diameter of the cylinder is 300 mm and the steam pressure is 1 N/mm<sup>2</sup>. The allowable stresses for the material of cotter and piston rod are as follows:  $\sigma_t = 50$  MPa ;  $\tau = 40$  MPa ; and  $\sigma_c = 84$  MPa

**Solution. Given :**  $D = 300$  mm ;  $p = 1$  N/mm<sup>2</sup> ;  $\sigma_t = 50$  MPa = 50 N/mm<sup>2</sup> ;  $\tau = 40$  MPa = 40 N/mm<sup>2</sup> ;  $\sigma_c = 84$  MPa = 84 N/mm<sup>2</sup>

We know that maximum load on the piston rod,

$$P = \frac{\pi}{4} \times D^2 \times p = \frac{\pi}{4} (300)^2 \times 1 = 70\,695 \text{ N}$$

The various dimensions for the cotter joint are obtained by considering the different modes of failure as discussed below :

1. *Diameter of piston rod at cotter*

Let  $d_2$  = Diameter of piston rod at cotter, and  
 $t$  = Thickness of cotter. It may be taken as  $0.3 d_2$ .

Considering the failure of piston rod in tension at cotter. We know that load ( $P$ ),

$$70\,695 = \left[ \frac{\pi}{4} (d_2)^2 - d_2 \times t \right] \sigma_t = \left[ \frac{\pi}{4} (d_2)^2 - 0.3 (d_2)^2 \right] 50 = 24.27 (d_2)^2$$

$$\therefore (d_2)^2 = 70\,695 / 24.27 = 2913 \quad \text{or} \quad d_2 = 53.97 \text{ say } 55 \text{ mm Ans.}$$

and  $t = 0.3 d_2 = 0.3 \times 55 = 16.5 \text{ mm Ans.}$

2. *Width of cotter*

Let  $b$  = Width of cotter.

Considering the failure of cotter in shear. Since the cotter is in double shear, therefore load ( $P$ ),

$$70\,695 = 2 b \times t \times \tau = 2 b \times 16.5 \times 40 = 1320 b$$

$$\therefore b = 70\,695 / 1320 = 53.5 \text{ say } 54 \text{ mm Ans.}$$

3. *Diameter of socket*

Let  $d_3$  = Diameter of socket.

Considering the failure of socket in tension at cotter. We know that load ( $P$ ),

$$\begin{aligned} 70\,695 &= \left\{ \frac{\pi}{4} [(d_3)^2 - (d_2)^2] - (d_3 - d_2) t \right\} \sigma_t \\ &= \left\{ \frac{\pi}{4} [(d_3)^2 - (55)^2] - (d_3 - 55) 16.5 \right\} 50 \\ &= 39.27 (d_3)^2 - 118\,792 - 825 d_3 + 45\,375 \end{aligned}$$



or  $(d_3)^2 - 21 d_3 - 3670 = 0$

$$\therefore d_3 = \frac{21 + \sqrt{(21)^2 + 4 \times 3670}}{2} = \frac{21 + 123}{2} = 72 \text{ mm} \quad \dots (\text{Taking +ve sign})$$

Let us now check the induced crushing stress in the socket. We know that load ( $P$ ),

$$70\,695 = (d_3 - d_2) l \times \sigma_c = (72 - 55) 16.5 \times \sigma_c = 280.5 \sigma_c$$

$$\therefore \sigma_c = 70\,695 / 280.5 = 252 \text{ N/mm}^2$$

Since the induced crushing is greater than the permissible value of  $84 \text{ N/mm}^2$ , therefore let us

find the value of  $d_3$  by substituting  $\sigma_c = 84 \text{ N/mm}^2$  in the above expression, *i.e.*

$$70\,695 = (d_3 - 55) 16.5 \times 84 = (d_3 - 55) 1386$$

$$\therefore d_3 - 55 = 70\,695 / 1386 = 51$$

or  $d_3 = 55 + 51 = 106 \text{ mm Ans.}$

We know the tapered length of the piston rod,

$$L = 2.2 d_2 = 2.2 \times 55 = 121 \text{ mm Ans.}$$

Assuming the taper of the piston rod as 1 in 20, therefore the diameter of the parallel part of the piston rod,

$$d = d_2 + \frac{L}{2} \times \frac{1}{20} = 55 + \frac{121}{2} \times \frac{1}{20} = 58 \text{ mm Ans.}$$

and diameter of the piston rod at the tapered end,

$$d_1 = d_2 - \frac{L}{2} \times \frac{1}{20} = 55 - \frac{121}{2} \times \frac{1}{20} = 52 \text{ mm Ans.}$$

#### References:

1. Machine Design - V. Bandari .
2. Machine Design – R.S. Khurmi
3. Design Data hand Book - S MD Jalaludin.

**DESIGN OF KNUCKLE JOINT**

The following figure shows a knuckle joint with the size parameters and proportions indicated. In general, the rods connected by this joint are subjected to tensile loads, although if the rods are guided, they may support compressive loads as well.

Let  $F$  = tensile load to be resisted by the joint

$d$  = diameter of the rods

$d_1$  = diameter of the knuckle pin

$D$  = outside diameter of the eye

$A$  = thickness of the fork

$B$  = thickness of the eye

Obviously, if the rods are made of the same material, the parameters,  $A$  and  $B$  are related as,

$$B=2A$$

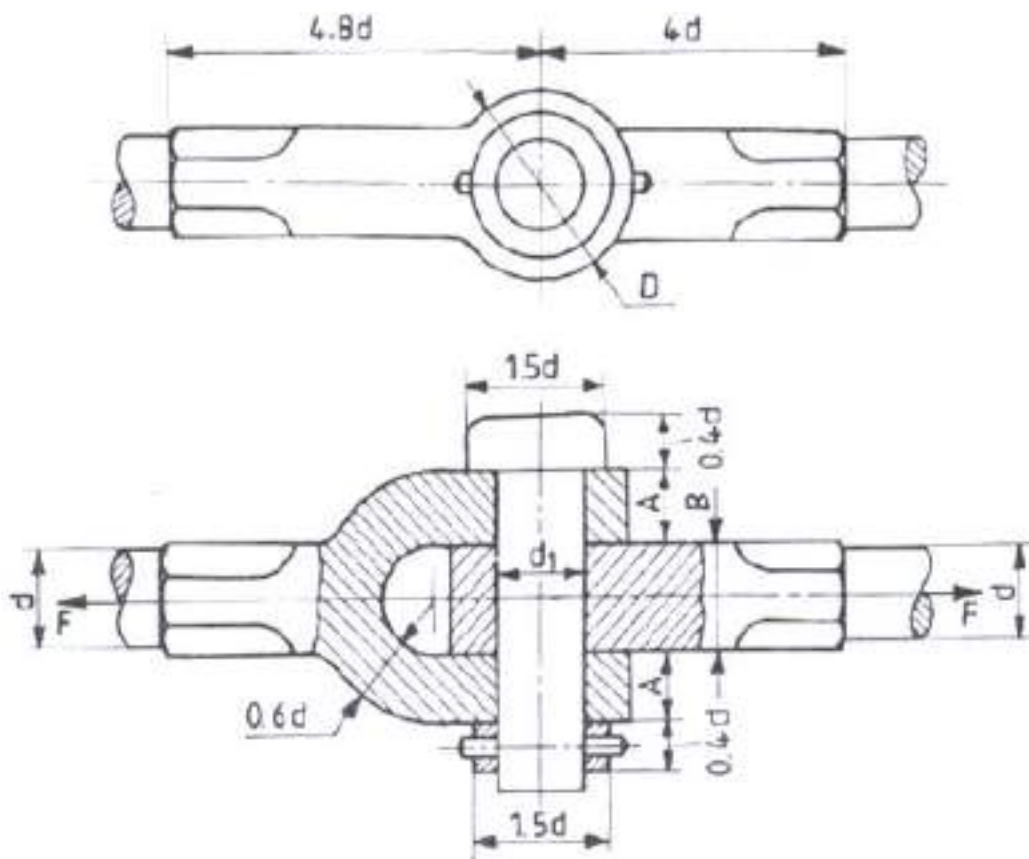

Fig. Knuckle Joint

Let the rods and pin are made of the same material, with  $\sigma_t$ ,  $\sigma_c$  and  $\tau$  as the permissible stresses. The following are the possible modes of failure, and the corresponding design equations, which may be considered for the design of the joint:

1. Tension failure of the rod, across the section of diameter,  $d$

$$F = \frac{\pi d^2}{4} \tau$$

2. Tension failure of the eye (fig.1)

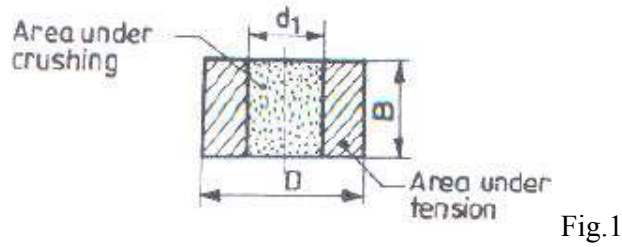

$$F = (D-d_1) B \sigma_t$$

3. Tension failure of the fork (fig.2)

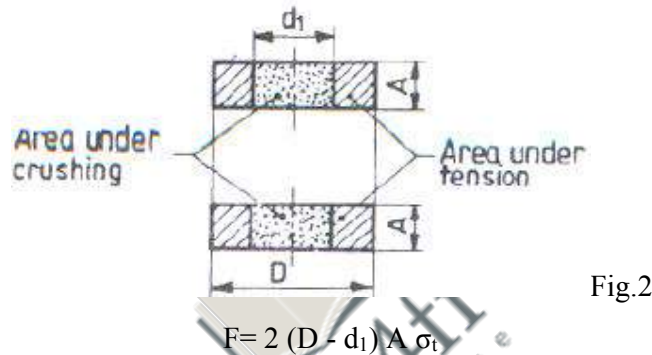

$$F = 2 (D - d_1) A \sigma_t$$

4. Shear failure of the eye (Fig.3)

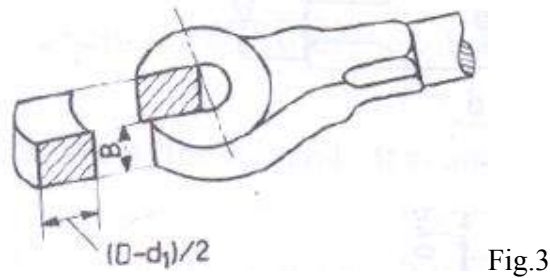

$$F = (D-d_1) B \tau$$

5. Shear failure of the fork (Fig.4)

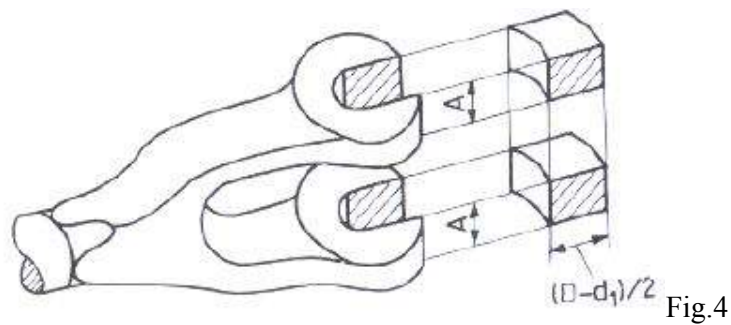

$$F = 2 (D-d_1) A \tau$$

6. Shear failure of the pin. It is under double shear.

$$F = 2x \frac{\pi}{4} d^2 x \tau$$

7. Crushing between the pin and eye (fig.1)

$$F = d_1 B \sigma_c$$

8. Crushing between the pin and fork (fig.2)

$$F = 2 d_1 A \sigma_c$$

For size parameters, not covered by the above design equations; proportions as indicated in the figure may be followed.

Problem:

Design a knuckle joint to transmit 150 kN. The design stresses may be taken as 75 MPa in tension, 60 MPa in shear and 150 MPa in compression.

Solution. Given :  $P = 150 \text{ kN} = 150 \times 10^3 \text{ N}$  ;  $\sigma_t = 75 \text{ MPa} = 75 \text{ N/mm}^2$  ;  $\tau = 60 \text{ MPa} = 60 \text{ N/mm}^2$  ;  $\sigma_c = 150 \text{ MPa} = 150 \text{ N/mm}^2$

1. Failure of the solid rod in tension

Let  $d =$  Diameter of the rod.

We know that the load transmitted ( $P$ ),

$$150 \times 10^3 = \frac{\pi}{4} \times d^2 \times \sigma_t = \frac{\pi}{4} \times d^2 \times 75 = 59 d^2$$

$$\therefore d^2 = 150 \times 10^3 / 59 = 2540 \quad \text{or} \quad d = 50.4 \text{ say } 52 \text{ mm Ans.}$$

Now the various dimensions are fixed as follows :

Diameter of knuckle pin,

$$d_1 = d = 52 \text{ mm}$$

Outer diameter of eye,  $d_2 = 2d = 2 \times 52 = 104 \text{ mm}$

Diameter of knuckle pin head and collar,

$$d_3 = 1.5d = 1.5 \times 52 = 78 \text{ mm}$$

Thickness of single eye or rod end,

$$t = 1.25d = 1.25 \times 52 = 65 \text{ mm}$$

Thickness of fork,  $t_1 = 0.75d = 0.75 \times 52 = 39 \text{ say } 40 \text{ mm}$

Thickness of pin head,  $t_2 = 0.5d = 0.5 \times 52 = 26 \text{ mm}$

2. Failure of the knuckle pin in shear

Since the knuckle pin is in double shear, therefore load ( $P$ ),

$$150 \times 10^3 = 2 \times \frac{\pi}{4} \times (d_1)^2 \tau = 2 \times \frac{\pi}{4} \times (52)^2 \tau = 4248 \tau$$

$$\therefore \tau = 150 \times 10^3 / 4248 = 35.3 \text{ N/mm}^2 = 35.3 \text{ MPa}$$

### 3. Failure of the single eye or rod end in tension

The single eye or rod end may fail in tension due to the load. We know that load ( $P$ ),

$$150 \times 10^3 = (d_2 - d_1) t \times \sigma_t = (104 - 52) 65 \times \sigma_t = 3380 \sigma_t$$

$$\therefore \sigma_t = 150 \times 10^3 / 3380 = 44.4 \text{ N/mm}^2 = 44.4 \text{ MPa}$$

### 4. Failure of the single eye or rod end in shearing

The single eye or rod end may fail in shearing due to the load. We know that load ( $P$ ),

$$150 \times 10^3 = (d_2 - d_1) t \times \tau = (104 - 52) 65 \times \tau = 3380 \tau$$

$$\therefore \tau = 150 \times 10^3 / 3380 = 44.4 \text{ N/mm}^2 = 44.4 \text{ MPa}$$

### 5. Failure of the single eye or rod end in crushing

The single eye or rod end may fail in crushing due to the load. We know that load ( $P$ ),

$$150 \times 10^3 = d_1 \times t \times \sigma_c = 52 \times 65 \times \sigma_c = 3380 \sigma_c$$

$$\therefore \sigma_c = 150 \times 10^3 / 3380 = 44.4 \text{ N/mm}^2 = 44.4 \text{ MPa}$$

### 6. Failure of the forked end in tension

The forked end may fail in tension due to the load. We know that load ( $P$ ),

$$150 \times 10^3 = (d_2 - d_1) 2 t_1 \times \sigma_t = (104 - 52) 2 \times 40 \times \sigma_t = 4160 \sigma_t$$

$$\therefore \sigma_t = 150 \times 10^3 / 4160 = 36 \text{ N/mm}^2 = 36 \text{ MPa}$$

### 7. Failure of the forked end in shear

The forked end may fail in shearing due to the load. We know that load ( $P$ ),

$$150 \times 10^3 = (d_2 - d_1) 2 t_1 \times \tau = (104 - 52) 2 \times 40 \times \tau = 4160 \tau$$

$$\therefore \tau = 150 \times 10^3 / 4160 = 36 \text{ N/mm}^2 = 36 \text{ MPa}$$

### 8. Failure of the forked end in crushing

The forked end may fail in crushing due to the load. We know that load ( $P$ ),

$$150 \times 10^3 = d_1 \times 2 t_1 \times \sigma_c = 52 \times 2 \times 40 \times \sigma_c = 4160 \sigma_c$$

$$\therefore \sigma_c = 150 \times 10^3 / 4160 = 36 \text{ N/mm}^2 = 36 \text{ MPa}$$

From above, we see that the induced stresses are less than the given design stresses, therefore the joint is safe.

#### References:

1. Machine Design - V. Bandari .
2. Machine Design – R.S. Khurmi
3. Design Data hand Book - S MD Jalaludin.

**Shafts:**

A shaft is a rotating machine element which is used to transmit power from one place to another. The power is delivered to the shaft by some tangential force and the resultant torque (or twisting moment) set up within the shaft permits the power to be transferred to various machines linked up to the shaft. In order to transfer the power from one shaft to another, the various members such as pulleys, gears etc., are mounted on it. These members along with the forces exerted upon them causes the shaft to bending.

In other words, we may say that a shaft is used for the transmission of torque and bending moment. The various members are mounted on the shaft by means of keys or splines. The shafts are usually cylindrical, but may be square or cross-shaped in section. They are solid in cross-section but sometimes hollow shafts are also used. An *axle*, though similar in shape to the shaft, is a stationary machine element and is used for the transmission of bending moment only. It simply acts as a support for some rotating body such as hoisting drum, a car wheel or a rope sheave. A *spindle* is a short shaft that imparts motion either to a cutting tool (e.g. drill press spindles) or to a work piece (e.g. lathe spindles).

**Types of Shafts**

The following two types of shafts are important from the subject point of view:

- 1. Transmission shafts.** These shafts transmit power between the source and the machines absorbing power. The counter shafts, line shafts, over head shafts and all factory shafts are transmission shafts. Since these shafts carry machine parts such as pulleys, gears etc., therefore they are subjected to bending in addition to twisting.
- 2. Machine shafts.** These shafts form an integral part of the machine itself. The crank shaft is an example of machine shaft.

**Stresses in Shafts**

The following stresses are induced in the shafts:

- 1.** Shear stresses due to the transmission of torque (*i.e.* due to torsional load).
- 2.** Bending stresses (tensile or compressive) due to the forces acting upon machine elements like gears, pulleys etc. as well as due to the weight of the shaft itself.
- 3.** Stresses due to combined torsional and bending loads.

**Design of Shafts**

The shafts may be designed on the basis of

- 1.** Strength, and **2.** Rigidity and stiffness.

In designing shafts on the basis of strength, the following cases may be considered:

- (a) Shafts subjected to twisting moment or torque only,
- (b) Shafts subjected to bending moment only,
- (c) Shafts subjected to combined twisting and bending moments, and
- (d) Shafts subjected to axial loads in addition to combined torsional and bending loads.

**Shafts Subjected to Twisting Moment Only**

**a) Solid shaft:**

When the shaft is subjected to a twisting moment (or torque) only, then the diameter of the shaft may be obtained by using the torsion equation. We know that

$$\frac{T}{J} = \frac{\tau}{r}$$

Where  $T$  = Twisting moment (or torque) acting upon the shaft,

$J$  = Polar moment of inertia of the shaft about the axis of rotation,

$\tau$  = Torsional shear stress, and

$r$  = Distance from neutral axis to the outer most fibre

=  $d / 2$ ; where  $d$  is the diameter of the shaft.

We know that for round solid shaft, polar moment of inertia,

$$J = \frac{\pi}{32} d^4$$

Then we get,

$$T = \frac{\pi d^3}{16} \tau$$

From this equation, diameter of the solid shaft ( $d$ ) may be obtained.

**b) Hollow Shaft:**

We also know that for hollow shaft, polar moment of inertia,

$$J = \frac{\pi}{32} [(d_o)^4 - (d_i)^4]$$

Where  $d_o$  and  $d_i$  = Outside and inside diameter of the shaft, and  $r = d_o / 2$ .

Substituting these values in equation (i), we have

$$\frac{T}{\frac{\pi}{32} [(d_o)^4 - (d_i)^4]} = \frac{\tau}{\frac{d_o}{2}} \quad \text{or} \quad T = \frac{\pi}{16} \times \tau \left[ \frac{(d_o)^4 - (d_i)^4}{d_o} \right]$$

Let  $k$  = Ratio of inside diameter and outside diameter of the shaft =  $d_i / d_o$

Now the equation (iii) may be written as

$$T = \frac{\pi}{16} \times \tau \times \frac{(d_o)^4}{d_o} \left[ 1 - \left( \frac{d_i}{d_o} \right)^4 \right] = \frac{\pi}{16} \times \tau (d_o)^3 (1 - k^4)$$

From the equations, the outside and inside diameter of a hollow shaft may be determined.

It may be noted that

1. The hollow shafts are usually used in marine work. These shafts are stronger per kg of material and they may be forged on a mandrel, thus making the material more homogeneous than would be possible for a solid shaft. When a hollow shaft is to be made equal in strength to a solid shaft, the twisting moment of both the shafts must be same. In other words, for the same material of both the shafts,

$$T = \frac{\pi}{16} \times \tau \left[ \frac{(d_o)^4 - (d_i)^4}{d_o} \right] = \frac{\pi}{16} \times \tau \times d^3$$

$$\therefore \frac{(d_o)^4 - (d_i)^4}{d_o} = d^3 \quad \text{or} \quad (d_o)^3 (1 - k^4) = d^3$$

2. The twisting moment ( $T$ ) may be obtained by using the following relation:

We know that the power transmitted (in watts) by the shaft,

$$P = \frac{2\pi N \times T}{60} \quad \text{or} \quad T = \frac{P \times 60}{2\pi N}$$

Where  $T$  = Twisting moment in N-m, and

$N$  = Speed of the shaft in r.p.m.

3. In case of belt drives, the twisting moment ( $T$ ) is given by

$$T = (T_1 - T_2) R$$

Where  $T_1$  and  $T_2$  = Tensions in the tight side and slack side of the belt respectively, and  $R$  = Radius of the pulley.

### Shafts Subjected to Bending Moment Only

#### a) Solid Shaft:

When the shaft is subjected to a bending moment only, then the maximum stress (tensile or compressive) is given by the bending equation. We know that

$$\frac{M}{I} = \frac{\sigma_b}{y}$$

Where  $M$  = Bending moment,

$I$  = Moment of inertia of cross-sectional area of the shaft about the axis of rotation,

$\sigma_b$  = Bending stress, and

$y$  = Distance from neutral axis to the outer-most fibre.



We know that for a round solid shaft, moment of inertia,

$$I = \frac{\pi}{64} \times d^4 \quad \text{and} \quad y = \frac{d}{2}$$

Substituting these values in equation

$$\frac{M}{\frac{\pi}{64} \times d^4} = \frac{\sigma_b}{\frac{d}{2}} \quad \text{or} \quad M = \frac{\pi}{32} \times \sigma_b \times d^3$$

From this equation, diameter of the solid shaft ( $d$ ) may be obtained.

**b) Hollow Shaft:**

We also know that for a hollow shaft, moment of inertia,

$$I = \frac{\pi}{64} [(d_o)^4 - (d_i)^4] = \frac{\pi}{64} (d_o)^4 (1 - k^4) \quad \dots(\text{where } k = d_i / d_o)$$

And  $y = d_o / 2$

Again substituting these values in equation, we have

$$\frac{M}{\frac{\pi}{64} (d_o)^4 (1 - k^4)} = \frac{\sigma_b}{\frac{d_o}{2}} \quad \text{or} \quad M = \frac{\pi}{32} \times \sigma_b (d_o)^3 (1 - k^4)$$

From this equation, the outside diameter of the shaft ( $d_o$ ) may be obtained.

**Shafts Subjected to Combined Twisting Moment and Bending Moment**

When the shaft is subjected to combined twisting moment and bending moment, then the shaft must be designed on the basis of the two moments simultaneously. Various theories have been suggested to account for the elastic failure of the materials when they are subjected to various types of combined stresses. The following two theories are important from the subject point of view:

1. Maximum shear stress theory or Guest's theory. It is used for ductile materials such as mild steel.
2. Maximum normal stress theory or Rankine's theory. It is used for brittle materials such as cast iron.

Let  $\tau$  = Shear stress induced due to twisting moment, and

$\sigma_b$  = Bending stress (tensile or compressive) induced due to bending moment.

**a) Solid Shaft:**

According to maximum shear stress theory, the maximum shear stress in the shaft,

$$\tau_{max} = \frac{1}{2} \sqrt{(\sigma_b)^2 + 4\tau^2}$$

Substituting the values of  $\sigma_b$  and  $\tau$

$$\tau_{max} = \frac{1}{2} \sqrt{\left(\frac{32M}{\pi d^3}\right)^2 + 4\left(\frac{16T}{\pi d^3}\right)^2} = \frac{16}{\pi d^3} \left[\sqrt{M^2 + T^2}\right]$$

$$\text{or} \quad \frac{\pi}{16} \times \tau_{max} \times d^3 = \sqrt{M^2 + T^2}$$

The expression  $\sqrt{M^2 + T^2}$  is known as **equivalent twisting moment** and is denoted by  $T_e$ . The equivalent twisting moment may be defined as that twisting moment, which when acting alone, produces the same shear stress ( $\tau$ ) as the actual twisting moment. By limiting the maximum shear stress ( $\tau_{max}$ ) equal to the allowable shear stress ( $\tau$ ) for the material, the equation (i) may be written as

$$T_e = \sqrt{M^2 + T^2} = \frac{\pi}{16} \times \tau \times d^3$$

From this expression, diameter of the shaft (d) may be evaluated.

Now according to maximum normal stress theory, the maximum normal stress in the shaft,

$$\begin{aligned} \sigma_{b(max)} &= \frac{1}{2} \sigma_b + \frac{1}{2} \sqrt{(\sigma_b)^2 + 4\tau^2} \\ &= \frac{1}{2} \times \frac{32M}{\pi d^3} + \frac{1}{2} \sqrt{\left(\frac{32M}{\pi d^3}\right)^2 + 4\left(\frac{16T}{\pi d^3}\right)^2} \\ &= \frac{32}{\pi d^3} \left[ \frac{1}{2} (M + \sqrt{M^2 + T^2}) \right] \end{aligned}$$

$$\text{or} \quad \frac{\pi}{32} \times \sigma_{b(max)} \times d^3 = \frac{1}{2} [M + \sqrt{M^2 + T^2}]$$

The expression  $\frac{1}{2}[M + \sqrt{M^2 + T^2}]$  is known as **equivalent bending moment** and is denoted by  $M_e$ . The equivalent bending moment may be defined as that moment which when acting alone produces the same tensile or compressive stress ( $\sigma_b$ ) as the actual bending moment. By limiting the maximum normal stress [ $\sigma_{b(max)}$ ] equal to the allowable bending stress ( $\sigma_b$ ), then the equation (iv) may be written as

$$M_e = \frac{1}{2} [M + \sqrt{M^2 + T^2}] = \frac{\pi}{32} \times \sigma_b \times d^3$$

From this expression, diameter of the shaft (d) may be evaluated.

**b) Hollow shaft:**

In case of a hollow shaft, the equations (ii) and (v) may be written as

$$T_e = \sqrt{M^2 + T^2} = \frac{\pi}{16} \times \tau (d_o)^3 (1 - k^4)$$

$$M_e = \frac{1}{2} \left( M + \sqrt{M^2 + T^2} \right) = \frac{\pi}{32} \times \sigma_b (d_o)^3 (1 - k^4)$$

It is suggested that diameter of the shaft may be obtained by using both the theories and the larger of the two values is adopted.

**References:**

1. Machine Design - V. Bandari .
2. Machine Design – R.S. Khurmi
3. Design Data hand Book - S MD Jalaludin.



Problem:

A shaft is supported by two bearings placed 1 m apart. A 600 mm diameter pulley is mounted at a distance of 300 mm to the right of left hand bearing and this drives a pulley directly below it with the help of belt having maximum tension of 2.25 kN. Another pulley 400 mm diameter is placed 200 mm to the left of right hand bearing and is driven with the help of electric motor and belt, which is placed horizontally to the right. The angle of contact for both the pulleys is  $180^\circ$  and  $\mu = 0.24$ . Determine the suitable diameter for a solid shaft, allowing working stress of 63 MPa in tension and 42 MPa in shear for the material of shaft. Assume that the torque on one pulley is equal to that on the other pulley.

**Solution.** Given :  $AB = 800 \text{ mm}$  ;  $\alpha_C = 20^\circ$  ;  $D_C = 600 \text{ mm}$  or  $R_C = 300 \text{ mm}$  ;  $AC = 200 \text{ mm}$  ;  $D_D = 700 \text{ mm}$  or  $R_D = 350 \text{ mm}$  ;  $DB = 250 \text{ mm}$  ;  $\theta = 180^\circ = \pi \text{ rad}$  ;  $W = 2000 \text{ N}$  ;  $T_1 = 3000 \text{ N}$  ;  $T_1/T_2 = 3$  ;  $\tau = 40 \text{ MPa} = 40 \text{ N/mm}^2$

The space diagram of the shaft is shown in Fig (a).

We know that the torque acting on the shaft at  $D$ ,

$$\begin{aligned} T &= (T_1 - T_2) R_D = T_1 \left( 1 - \frac{T_2}{T_1} \right) R_D \\ &= 3000 \left( 1 - \frac{1}{3} \right) 350 = 700 \times 10^3 \text{ N-mm} \quad \dots(\because T_1/T_2 = 3) \end{aligned}$$

The torque diagram is shown in Fig. (b).

Assuming that the torque at  $D$  is equal to the torque at  $C$ , therefore the tangential force acting on the gear  $C$ ,

$$F_{tc} = \frac{T}{R_C} = \frac{700 \times 10^3}{300} = 2333 \text{ N}$$

and the normal load acting on the tooth of gear  $C$ ,

$$W_C = \frac{F_{tc}}{\cos \alpha_C} = \frac{2333}{\cos 20^\circ} = \frac{2333}{0.9397} = 2483 \text{ N}$$

The normal load acts at  $20^\circ$  to the vertical as shown in Fig.

Resolving the normal load vertically and horizontally, we get

Vertical component of  $W_C$  i.e. the vertical load acting on the shaft at  $C$ ,

$$\begin{aligned} W_{CV} &= W_C \cos 20^\circ \\ &= 2483 \times 0.9397 = 2333 \text{ N} \end{aligned}$$

and horizontal component of  $W_C$  i.e. the horizontal load acting on the shaft at  $C$ ,

$$\begin{aligned} W_{CH} &= W_C \sin 20^\circ \\ &= 2483 \times 0.342 = 849 \text{ N} \end{aligned}$$

Since  $T_1/T_2 = 3$  and  $T_1 = 3000 \text{ N}$ , therefore

$$T_2 = T_1 / 3 = 3000 / 3 = 1000 \text{ N}$$

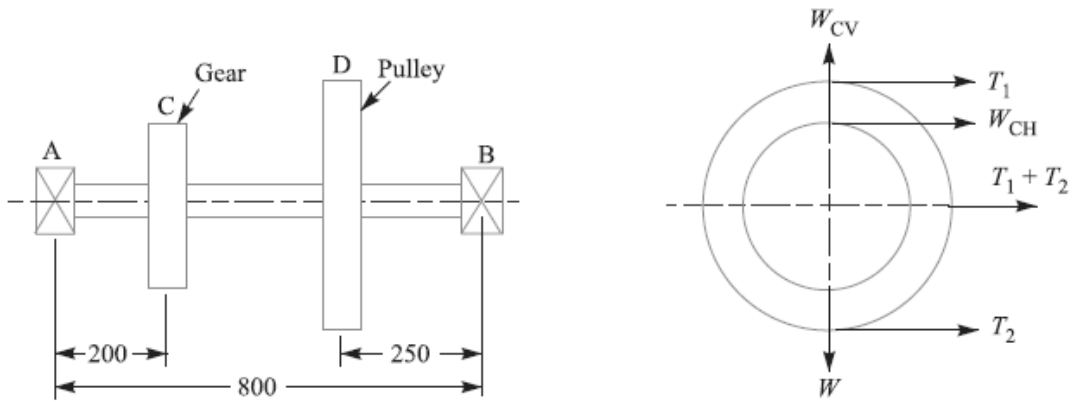

All dimensions in mm.

(a) Space diagram.

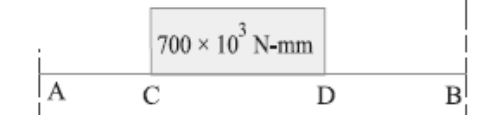

(b) Torque diagram.

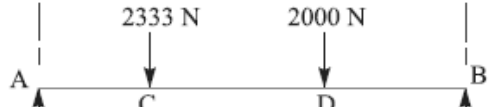

(c) Vertical load diagram.



(d) Horizontal load diagram.

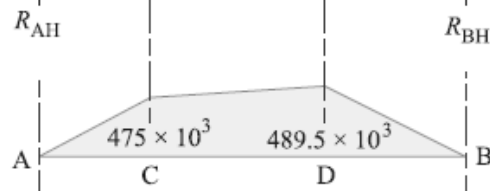

(e) Vertical B.M. diagram.

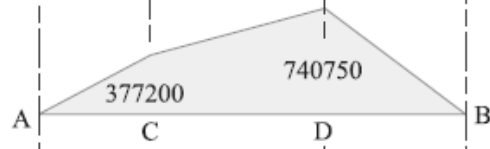

(f) Horizontal B.M. diagram.

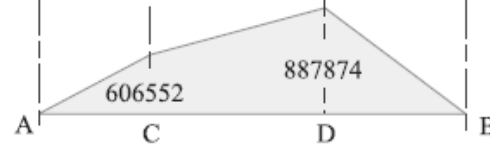

(g) Resultant B.M. diagram.

∴ Horizontal load acting on the shaft at D,

$$W_{DE} = T_1 + T_2 = 3000 + 1000 = 4000 \text{ N}$$

and vertical load acting on the shaft at D,

$$W_{DV} = W = 2000 \text{ N}$$

The vertical and horizontal load diagram at  $C$  and  $D$  is shown in Fig. 14.6 (c) and (d) respectively.

Now let us find the maximum bending moment for vertical and horizontal loading.

First of all considering the vertical loading at  $C$  and  $D$ . Let  $R_{AV}$  and  $R_{BV}$  be the reactions at the bearings  $A$  and  $B$  respectively. We know that

$$R_{AV} + R_{BV} = 2333 + 2000 = 4333 \text{ N}$$

Taking moments about  $A$ , we get

$$R_{BV} \times 800 = 2000 (800 - 250) + 2333 \times 200 \\ = 1\,566\,600$$

$$\therefore R_{BV} = 1\,566\,600 / 800 = 1958 \text{ N}$$

and  $R_{AV} = 4333 - 1958 = 2375 \text{ N}$

We know that B.M. at  $A$  and  $B$ ,

$$M_{AV} = M_{BV} = 0$$

B.M. at  $C$ ,  $M_{CV} = R_{AV} \times 200 = 2375 \times 200 \\ = 475 \times 10^3 \text{ N-mm}$

B.M. at  $D$ ,  $M_{DV} = R_{BV} \times 250 = 1958 \times 250 = 489.5 \times 10^3 \text{ N-mm}$

The bending moment diagram for vertical loading is shown in Fig. 14.6 (e).

Now consider the horizontal loading at  $C$  and  $D$ . Let  $R_{AH}$  and  $R_{BH}$  be the reactions at the bearings  $A$  and  $B$  respectively. We know that

$$R_{AH} + R_{BH} = 849 + 4000 = 4849 \text{ N}$$

Taking moments about  $A$ , we get

$$R_{BH} \times 800 = 4000 (800 - 250) + 849 \times 200 = 2\,369\,800$$

$$\therefore R_{BH} = 2\,369\,800 / 800 = 2963 \text{ N}$$

and  $R_{AH} = 4849 - 2963 = 1886 \text{ N}$

We know that B.M. at  $A$  and  $B$ ,

$$M_{AH} = M_{BH} = 0$$

B.M. at  $C$ ,  $M_{CH} = R_{AH} \times 200 = 1886 \times 200 = 377\,200 \text{ N-mm}$

B.M. at  $D$ ,  $M_{DH} = R_{BH} \times 250 = 2963 \times 250 = 740\,750 \text{ N-mm}$

The bending moment diagram for horizontal loading is shown in Fig. 14.6 (f).

We know that resultant B.M. at  $C$ ,

$$M_C = \sqrt{(M_{CV})^2 + (M_{CH})^2} = \sqrt{(475 \times 10^3)^2 + (377\,200)^2} \\ = 606\,552 \text{ N-mm}$$

and resultant B.M. at  $D$ ,

$$M_D = \sqrt{(M_{DV})^2 + (M_{DH})^2} = \sqrt{(489.5 \times 10^3)^2 + (740\,750)^2} \\ = 887\,874 \text{ N-mm}$$

*Maximum bending moment*

The resultant B.M. diagram is shown in Fig. 14.6 (g). We see that the bending moment is maximum at  $D$ , therefore

Maximum B.M.,  $M = M_D = 887\,874 \text{ N-mm Ans.}$

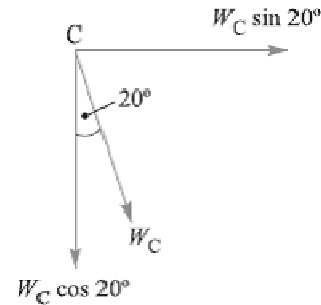

Fig. 14.7

*Diameter of the shaft*

Let  $d$  = Diameter of the shaft.

We know that the equivalent twisting moment,

$$T_e = \sqrt{M^2 + T^2} = \sqrt{(887\ 874)^2 + (700 \times 10^3)^2} = 1131 \times 10^3 \text{ N-mm}$$

We also know that equivalent twisting moment ( $T_e$ ),

$$1131 \times 10^3 = \frac{\pi}{16} \times \tau \times d^3 = \frac{\pi}{16} \times 40 \times d^3 = 7.86 d^3$$

$$\therefore d^3 = 1131 \times 10^3 / 7.86 = 144 \times 10^3 \text{ or } d = 52.4 \text{ say } 55 \text{ mm Ans.}$$

Problem:

A steel solid shaft transmitting 15 kW at 200 r.p.m. is supported on two bearings 750 mm apart and has two gears keyed to it. The pinion having 30 teeth of 5 mm module is located 100 mm to the left of the right hand bearing and delivers power horizontally to the right. The gear having 100 teeth of 5 mm module is located 150 mm to the right of the left hand bearing and receives power in a vertical direction from below. Using an allowable stress of 54 MPa in shear, determine the diameter of the shaft.

**Solution.** Given :  $P = 15 \text{ kW} = 15 \times 10^3 \text{ W}$  ;  $N = 200 \text{ r.p.m.}$  ;  $AB = 750 \text{ mm}$  ;  $T_D = 30$  ;  $m_D = 5 \text{ mm}$  ;  $BD = 100 \text{ mm}$  ;  $T_C = 100$  ;  $m_C = 5 \text{ mm}$  ;  $AC = 150 \text{ mm}$  ;  $\tau = 54 \text{ MPa} = 54 \text{ N/mm}^2$

The space diagram of the shaft is shown in Fig. 14.8 (a).

We know that the torque transmitted by the shaft,

$$T = \frac{P \times 60}{2\pi N} = \frac{15 \times 10^3 \times 60}{2\pi \times 200} = 716 \text{ N-m} = 716 \times 10^3 \text{ N-mm}$$

The torque diagram is shown in Fig. 14.8 (b).

We know that diameter of gear

$$= \text{No. of teeth on the gear} \times \text{module}$$

$\therefore$  Radius of gear C,

$$R_C = \frac{T_C \times m_C}{2} = \frac{100 \times 5}{2} = 250 \text{ mm}$$

and radius of pinion D,

$$R_D = \frac{T_D \times m_D}{2} = \frac{30 \times 5}{2} = 75 \text{ mm}$$

Assuming that the torque at C and D is same (i.e.  $716 \times 10^3 \text{ N-mm}$ ), therefore tangential force on the gear C, acting downward,

$$F_{tC} = \frac{T}{R_C} = \frac{716 \times 10^3}{250} = 2870 \text{ N}$$

and tangential force on the pinion D, acting horizontally,

$$F_{tD} = \frac{T}{R_D} = \frac{716 \times 10^3}{75} = 9550 \text{ N}$$

The vertical and horizontal load diagram is shown in Fig. 14.8 (c) and (d) respectively.

Now let us find the maximum bending moment for vertical and horizontal loading.

First of all, considering the vertical loading at C. Let  $R_{AV}$  and  $R_{BV}$  be the reactions at the bearings A and B respectively. We know that

$$R_{AV} + R_{BV} = 2870 \text{ N}$$

Taking moments about A, we get

$$R_{BV} \times 750 - 2870 \times 150$$

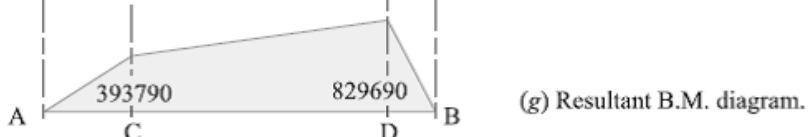
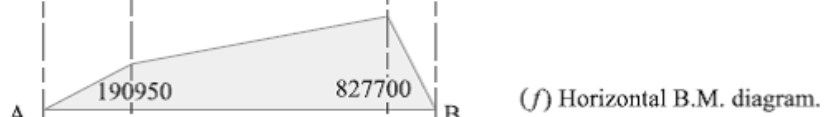
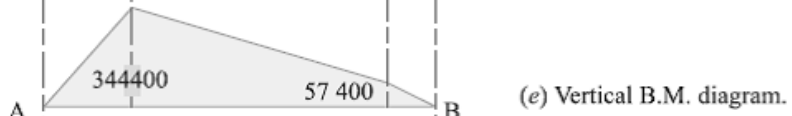
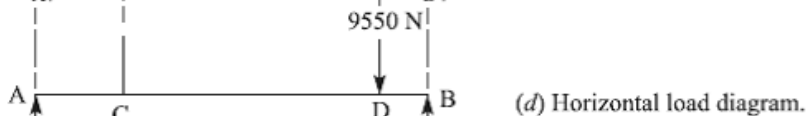
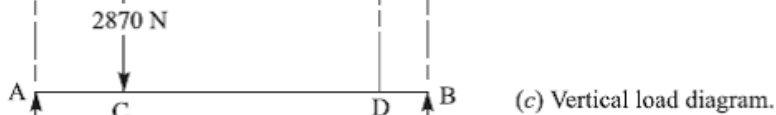
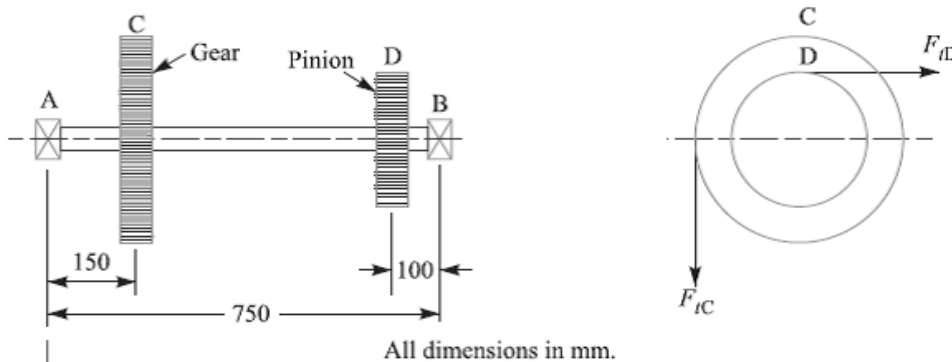



$$\therefore R_{BV} = 2870 \times 150 / 750 = 574 \text{ N}$$

$$\text{and } R_{AV} = 2870 - 574 = 2296 \text{ N}$$

We know that B.M. at  $A$  and  $B$ ,

$$M_{AV} = M_{BV} = 0$$

$$\text{B.M. at } C, \quad M_{CV} = R_{AV} \times 150 = 2296 \times 150 = 344\,400 \text{ N-mm}$$

$$\text{B.M. at } D, \quad M_{DV} = R_{BV} \times 100 = 574 \times 100 = 57\,400 \text{ N-mm}$$

The B.M. diagram for vertical loading is shown in Fig. 14.8 (e).

Now considering horizontal loading at  $D$ . Let  $R_{AH}$  and  $R_{BH}$  be the reactions at the bearings  $A$  and  $B$  respectively. We know that

$$R_{AH} + R_{BH} = 9550 \text{ N}$$

Taking moments about  $A$ , we get

$$R_{BH} \times 750 = 9550 (750 - 100) = 9550 \times 650$$

$$\therefore R_{BH} = 9550 \times 650 / 750 = 8277 \text{ N}$$

$$\text{and } R_{AH} = 9550 - 8277 = 1273 \text{ N}$$

We know that B.M. at  $A$  and  $B$ ,

$$M_{AH} = M_{BH} = 0$$

$$\text{B.M. at } C, \quad M_{CH} = R_{AH} \times 150 = 1273 \times 150 = 190\,950 \text{ N-mm}$$

$$\text{B.M. at } D, \quad M_{DH} = R_{BH} \times 100 = 8277 \times 100 = 827\,700 \text{ N-mm}$$

The B.M. diagram for horizontal loading is shown in Fig. 14.8 (f).

We know that resultant B.M. at  $C$ ,

$$M_C = \sqrt{(M_{CV})^2 + (M_{CH})^2} = \sqrt{(344\,400)^2 + (190\,950)^2}$$

$$= 393\,790 \text{ N-mm}$$

and resultant B.M. at  $D$ ,

$$M_D = \sqrt{(M_{DV})^2 + (M_{DH})^2} = \sqrt{(57\,400)^2 + (827\,700)^2}$$

$$= 829\,690 \text{ N-mm}$$

The resultant B.M. diagram is shown in Fig. 14.8 (g). We see that the bending moment is maximum at  $D$ .

$\therefore$  Maximum bending moment,

$$M = M_D = 829\,690 \text{ N-mm}$$

Let  $d$  = Diameter of the shaft.

We know that the equivalent twisting moment,

$$T_e = \sqrt{M^2 + T^2} = \sqrt{(829\,690)^2 + (716 \times 10^3)^2} = 1096 \times 10^3 \text{ N-mm}$$

We also know that equivalent twisting moment ( $T_e$ ),

$$1096 \times 10^3 = \frac{\pi}{16} \times \tau \times d^3 = \frac{\pi}{16} \times 54 \times d^3 = 10.6 d^3$$

$$\therefore d^3 = 1096 \times 10^3 / 10.6 = 103.4 \times 10^3$$

$$\text{or } d = 47 \text{ say } 50 \text{ mm Ans.}$$

### References:

1. Machine Design - V. Bandari .

2. Machine Design – R.S. Khurmi
3. Design Data hand Book - S MD Jalaludin.



**Shafts Subjected to Axial Load in addition to Combined Torsion and Bending Loads:**

When the shaft is subjected to an axial load ( $F$ ) in addition to torsion and bending loads as in propeller shafts of ships and shafts for driving worm gears, then the stress due to axial load must be added to the bending stress ( $\sigma_b$ ). We know that bending equation is

$$\frac{M}{I} = \frac{\sigma_b}{y} \quad \text{or} \quad \sigma_b = \frac{M \cdot y}{I} = \frac{M \times d/2}{\frac{\pi}{64} \times d^4} = \frac{32M}{\pi d^3}$$

And stress due to axial load

$$= \frac{F}{\frac{\pi}{4} \times d^2} = \frac{4F}{\pi d^2} \quad \dots(\text{For round solid shaft})$$

$$= \frac{F}{\frac{\pi}{4} [(d_o)^2 - (d_i)^2]} = \frac{4F}{\pi [(d_o)^2 - (d_i)^2]} \quad \dots(\text{For hollow shaft})$$

$$= \frac{F}{\pi (d_o)^2 (1 - k^2)} \quad \dots(\because k = d_i/d_o)$$

Resultant stress (tensile or compressive) for solid shaft,

$$\sigma_1 = \frac{32M}{\pi d^3} + \frac{4F}{\pi d^2} = \frac{32}{\pi d^3} \left( M + \frac{F \times d}{8} \right) \quad \dots(i)$$

$$= \frac{32M_1}{\pi d^3} \quad \dots\left(\text{Substituting } M_1 = M + \frac{F \times d}{8}\right)$$

In case of a hollow shaft, the resultant stress,

$$\begin{aligned} \sigma_1 &= \frac{32M}{\pi (d_o)^3 (1 - k^4)} + \frac{4F}{\pi (d_o)^2 (1 - k^2)} \\ &= \frac{32}{\pi (d_o)^3 (1 - k^4)} \left[ M + \frac{F d_o (1 + k^2)}{8} \right] = \frac{32M_1}{\pi (d_o)^3 (1 - k^4)} \end{aligned}$$

In case of long shafts (slender shafts) subjected to compressive loads, a factor known as **column factor** ( $\alpha$ ) must be introduced to take the column effect into account.

Therefore, Stress due to the compressive load,

$$\sigma_c = \frac{\alpha \times 4F}{\pi d^2}$$

or

$$= \frac{\alpha \times 4F}{\pi(d_o)^2 (1 - k^2)}$$

The value of column factor ( $\alpha$ ) for compressive loads\* may be obtained from the following relation :

Column factor,

$$\alpha = \frac{1}{1 - 0.0044 (L/K)^2}$$

This expression is used when the slenderness ratio ( $L / K$ ) is less than 115. When the slenderness ratio ( $L / K$ ) is more than 115, then the value of column factor may be obtained from the following relation:

Column factor,  $\alpha$

$$\alpha = \frac{\sigma_y (L/K)^2}{C \pi^2 E}$$

Where  $L$  = Length of shaft between the bearings,

$K$  = Least radius of gyration,

$\sigma_y$  = Compressive yield point stress of shaft material, and

$C$  = Coefficient in Euler's formula depending upon the end conditions.

The following are the different values of  $C$  depending upon the end conditions.

$C = 1$ , for hinged ends,

$C = 2.25$ , for fixed ends,

$C = 1.6$ , for ends that are partly restrained as in bearings.

In general, for a hollow shaft subjected to fluctuating torsional and bending load, along with an axial load, the equations for equivalent twisting moment ( $T_e$ ) and equivalent bending moment ( $M_e$ ) may be written as

$$T_e = \sqrt{\left[ K_m \times M + \frac{\alpha F d_o (1 + k^2)}{8} \right]^2 + (K_t \times T)^2}$$

$$= \frac{\pi}{16} \times \tau (d_o)^3 (1 - k^4)$$

$$M_e = \frac{1}{2} \left[ K_m \times M + \frac{\alpha F d_o (1 + k^2)}{8} + \sqrt{\left\{ K_m \times M + \frac{\alpha F d_o (1 + k^2)}{8} \right\}^2 + (K_t \times T)^2} \right]$$

$$= \frac{\pi}{32} \times \sigma_b (d_o)^3 (1 - k^4)$$

It may be noted that for a solid shaft,  $k = 0$  and  $d_o = d$ . When the shaft carries no axial load, then  $F = 0$  and when the shaft carries axial tensile load, then  $\alpha = 1$ .

**References:**

1. Machine Design - V.Bandari .
2. Machine Design – R.S. Khurmi
3. Design Data hand Book - S MD Jalaludin.



Problem:

A hollow shaft is subjected to a maximum torque of 1.5 kN-m and a maximum bending moment of 3 kN-m. It is subjected, at the same time, to an axial load of 10 kN. Assume that the load is applied gradually and the ratio of the inner diameter to the outer diameter is 0.5. If the outer diameter of the shaft is 80 mm, find the shear stress induced in the shaft.

**Solution.** Given:  $T = 1.5 \text{ kN-m} = 1.5 \times 10^3 \text{ N-m}$  ;  $M = 3 \text{ kN-m} = 3 \times 10^3 \text{ N-m}$  ;

$F = 10 \text{ kN} = 10 \times 10^3 \text{ N}$  ;  $k = d_i / d_o = 0.5$  ;  $d_o = 80 \text{ mm} = 0.08 \text{ m}$

Let  $\tau$  = Shear stress induced in the shaft.

Since the load is applied gradually, therefore from DDB, we find that  $K_m = 1.5$  ; and  $K_t = 1.0$

We know that the equivalent twisting moment for a hollow shaft,

$$\begin{aligned} T_e &= \sqrt{\left[ K_m \times M + \frac{\alpha F d_o (1 + k^2)^2}{8} \right]^2 + (K_t \times T)^2} \\ &= \sqrt{\left[ 1.5 \times 3 \times 10^3 + \frac{1 \times 10 \times 10^3 \times 0.08 (1 + 0.5^2)^2}{8} \right]^2 + (1 \times 1.5 \times 10^3)^2} \\ &= \sqrt{(4500 + 125)^2 + (1500)^2} = 4862 \text{ N-m} = 4862 \times 10^3 \text{ N-mm} \end{aligned}$$

We also know that the equivalent twisting moment for a hollow shaft ( $T_e$ ),

$$\begin{aligned} 4862 \times 10^3 &= \frac{\pi}{16} \times \tau (d_o)^3 (1 - k^4) = \frac{\pi}{16} \times \tau (80)^3 (1 - 0.5^4) = 94\,260 \tau \\ \therefore \tau &= 4862 \times 10^3 / 94\,260 = 51.6 \text{ N/mm}^2 = 51.6 \text{ MPa Ans.} \end{aligned}$$

Problem:

A hollow shaft of 0.5 m outside diameter and 0.3 m inside diameter is used to drive a propeller of a marine vessel. The shaft is mounted on bearings 6 metre apart and it transmits 5600 kW at 150 r.p.m. The maximum axial propeller thrust is 500 kN and the shaft weighs 70 kN.

Determine:

1. The maximum shear stress developed in the shaft, and
2. The angular twist between the bearings.

**Solution.** Given :  $d_o = 0.5 \text{ m}$  ;  $d_i = 0.3 \text{ m}$  ;  $P = 5600 \text{ kW} = 5600 \times 10^3 \text{ W}$  ;  $L = 6 \text{ m}$  ;  
 $N = 150 \text{ r.p.m.}$  ;  $F = 500 \text{ kN} = 500 \times 10^3 \text{ N}$  ;  $W = 70 \text{ kN} = 70 \times 10^3 \text{ N}$

1. *Maximum shear stress developed in the shaft*

Let  $\tau$  = Maximum shear stress developed in the shaft.

We know that the torque transmitted by the shaft,

$$T = \frac{P \times 60}{2\pi N} = \frac{5600 \times 10^3 \times 60}{2\pi \times 150} = 356\,460 \text{ N-m}$$

and the maximum bending moment,

$$M = \frac{W \times L}{8} = \frac{70 \times 10^3 \times 6}{8} = 52\,500 \text{ N-m}$$

Now let us find out the column factor  $\alpha$ . We know that least radius of gyration,

$$\begin{aligned} K &= \sqrt{\frac{I}{A}} = \sqrt{\frac{\frac{\pi}{64} [(d_o)^4 - (d_i)^4]}{\frac{\pi}{4} [(d_o)^2 - (d_i)^2]}} \\ &= \sqrt{\frac{[(d_o)^2 + (d_i)^2][(d_o)^2 - (d_i)^2]}{16 [(d_o)^2 - (d_i)^2]}} \\ &= \frac{1}{4} \sqrt{(d_o)^2 + (d_i)^2} = \frac{1}{4} \sqrt{(0.5)^2 + (0.3)^2} = 0.1458 \text{ m} \end{aligned}$$

$\therefore$  Slenderness ratio,

$$L / K = 6 / 0.1458 = 41.15$$

and column factor,  $\alpha = \frac{1}{1 - 0.0044 \left(\frac{L}{K}\right)} \dots \left(\because \frac{L}{K} < 115\right)$

$$= \frac{1}{1 - 0.0044 \times 41.15} = \frac{1}{1 - 0.18} = 1.22$$

Assuming that the load is applied gradually, therefore from Table 14.2, we find that

$$K_m = 1.5 \text{ and } K_t = 1.0$$

Also  $k = d_i / d_o = 0.3 / 0.5 = 0.6$

We know that the equivalent twisting moment for a hollow shaft,

$$\begin{aligned} T_e &= \sqrt{\left[ K_m \times M + \frac{\alpha F d_o (1 + k^2)}{8} \right]^2 + (K_t \times T)^2} \\ &= \sqrt{\left[ 1.5 \times 52\,500 + \frac{1.22 \times 500 \times 10^3 \times 0.5 (1 + 0.6^2)}{8} \right]^2 + (1 \times 356\,460)^2} \\ &= \sqrt{(78\,750 + 51\,850)^2 + (356\,460)^2} = 380 \times 10^3 \text{ N-m} \end{aligned}$$

We also know that the equivalent twisting moment for a hollow shaft ( $T_e$ ),

$$380 \times 10^3 = \frac{\pi}{16} \times \tau (d_o)^3 (1 - k^4) = \frac{\pi}{16} \times \tau (0.5)^3 [1 - (0.6)^4] = 0.02 \tau$$

$$\therefore \tau = 380 \times 10^3 / 0.02 = 19 \times 10^6 \text{ N/m}^2 = 19 \text{ MPa Ans.}$$

2. *Angular twist between the bearings*

Let  $\theta$  = Angular twist between the bearings in radians.

We know that the polar moment of inertia for a hollow shaft,

$$J = \frac{\pi}{32} [(d_o)^4 - (d_i)^4] = \frac{\pi}{32} [(0.5)^4 - (0.3)^4] = 0.00534 \text{ m}^4$$

From the torsion equation,

$$\frac{T}{J} = \frac{G \times \theta}{L}, \text{ we have}$$

$$\theta = \frac{T \times L}{G \times J} = \frac{356460 \times 6}{84 \times 10^9 \times 0.00534} = 0.0048 \text{ rad}$$

... (Taking  $G = 84 \text{ GPa} = 84 \times 10^9 \text{ N/m}^2$ )

$$= 0.0048 \times \frac{180}{\pi} = 0.275^\circ \text{ Ans.}$$

**References:**

1. Machine Design - V. Bandari .
2. Machine Design – R.S. Khurmi
3. Design Data hand Book - S MD Jalaludin.





**Design of Shafts on the basis of Rigidity**

Sometimes the shafts are to be designed on the basis of rigidity. We shall consider the following two types of rigidity.

**1. Torsional rigidity.** The torsional rigidity is important in the case of camshaft of an I.C. engine where the timing of the valves would be affected. The permissible amount of twist should not exceed  $0.25^\circ$  per metre length of such shafts. For line shafts or transmission shafts, deflections 2.5 to 3 degree per metre length may be used as limiting value. The widely used deflection for the shafts is limited to 1 degree in a length equal to twenty times the diameter of the shaft. The torsional deflection may be obtained by using the torsion equation,

$$\frac{T}{J} = \frac{G \cdot \theta}{L} \quad \text{or} \quad \theta = \frac{T \cdot L}{J \cdot G}$$

where  $\theta$  = Torsional deflection or angle of twist in radians,

T = Twisting moment or torque on the shaft,

J = Polar moment of inertia of the cross-sectional area about the axis of rotation,

G = Modulus of rigidity for the shaft material, and

L = Length of the shaft.

**2. Lateral rigidity.** It is important in case of transmission shafting and shafts running at high speed, where small lateral deflection would cause huge out-of-balance forces. The lateral rigidity is also important for maintaining proper bearing clearances and for correct gear teeth alignment. If the shaft is of uniform cross-section, then the lateral deflection of a shaft may be obtained by using the deflection formulae as in Strength of Materials. But when the shaft is of variable cross-section, then the lateral deflection may be determined from the fundamental equation for the elastic curve of a beam, *i.e.*

$$\frac{d^2 y}{dx^2} = \frac{M}{EI}$$

**BIS codes of Shafts**

The standard sizes of transmission shafts are:

25 mm to 60 mm with 5 mm steps; 60 mm to 110 mm with 10 mm steps ; 110 mm to 140 mm with 15 mm steps ; and 140 mm to 500 mm with 20 mm steps. The standard length of the shafts are 5 m, 6 m and 7 m.

:

**References:**

1. Machine Design - V.Bandari .
2. Machine Design – R.S. Khurmi
3. Design Data hand Book - S MD Jalaludin.



Problem:

A steel spindle transmits 4 kW at 800 r.p.m. The angular deflection should not exceed  $0.25^\circ$  per metre of the spindle. If the modulus of rigidity for the material of the spindle is 84 GPa, find the diameter of the spindle and the shear stress induced in the spindle.

**Solution.** Given :  $P = 4 \text{ kW} = 4000 \text{ W}$  ;  $N = 800 \text{ r.p.m.}$  ;  $\theta = 0.25^\circ = 0.25 \times \frac{\pi}{180} = 0.0044 \text{ rad}$  ;  
 $L = 1 \text{ m} = 1000 \text{ mm}$  ;  $G = 84 \text{ GPa} = 84 \times 10^9 \text{ N/m}^2 = 84 \times 10^3 \text{ N/mm}^2$

*Diameter of the spindle*

Let  $d =$  Diameter of the spindle in mm.

We know that the torque transmitted by the spindle,

$$T = \frac{P \times 60}{2\pi N} = \frac{4000 \times 60}{2\pi \times 800} = 47.74 \text{ N-m} = 47\,740 \text{ N-mm}$$

We also know that  $\frac{T}{J} = \frac{G \times \theta}{L}$  or  $J = \frac{T \times l}{G \times \theta}$

or  $\frac{\pi}{32} \times d^4 = \frac{47\,740 \times 1000}{84 \times 10^3 \times 0.0044} = 129\,167$

$\therefore d^4 = 129\,167 \times 32 / \pi = 1.3 \times 10^6$  or  $d = 33.87$  say 35 mm Ans.

*Shear stress induced in the spindle*

Let  $\tau =$  Shear stress induced in the spindle.

We know that the torque transmitted by the spindle ( $T$ ),

$$47\,740 = \frac{\pi}{16} \times \tau \times d^3 = \frac{\pi}{16} \times \tau (35)^3 = 8420 \tau$$

$\therefore \tau = 47\,740 / 8420 = 5.67 \text{ N/mm}^2 = 5.67 \text{ MPa}$  Ans.

### References:

1. Machine Design - V. Bandari .
2. Machine Design – R.S. Khurmi
3. Design Data hand Book - S MD Jalaludin.

Use of internal and external circlips, Gaskets and seals

**References:**

1. Machine Design - V.Bandari .
2. Machine Design – R.S. Khurmi
3. Design Data hand Book - S MD Jalaludin.





Problems:

Compare the weight, strength and stiffness of a hollow shaft of the same external diameter as that of solid shaft. The inside diameter of the hollow shaft being half the external diameter.

Both the shafts have the same material and length.

**Solution.** Given :  $d_o = d$  ;  $d_i = d_o / 2$  or  $k = d_i / d_o = 1 / 2 = 0.5$

*Comparison of weight*

We know that weight of a hollow shaft,

$$\begin{aligned} W_H &= \text{Cross-sectional area} \times \text{Length} \times \text{Density} \\ &= \frac{\pi}{4} [(d_o)^2 - (d_i)^2] \times \text{Length} \times \text{Density} \end{aligned} \quad \dots(i)$$

and weight of the solid shaft,

$$W_S = \frac{\pi}{4} \times d^2 \times \text{Length} \times \text{Density} \quad \dots(ii)$$

Since both the shafts have the same material and length, therefore by dividing equation (i) by equation (ii), we get

$$\begin{aligned} \frac{W_H}{W_S} &= \frac{(d_o)^2 - (d_i)^2}{d^2} = \frac{(d_o)^2 - (d_i)^2}{(d_o)^2} \quad \dots(\because d = d_o) \\ &= 1 - \frac{(d_i)^2}{(d_o)^2} = 1 - k^2 = 1 - (0.5)^2 = 0.75 \text{ Ans.} \end{aligned}$$

*Comparison of strength*

We know that strength of the hollow shaft,

$$T_H = \frac{\pi}{16} \times \tau (d_o)^3 (1 - k^4) \quad \dots(iii)$$

and strength of the solid shaft,

$$T_S = \frac{\pi}{16} \times \tau \times d^3 \quad \dots(iv)$$

Dividing equation (iii) by equation (iv), we get

$$\begin{aligned} \frac{T_H}{T_S} &= \frac{(d_o)^3 (1 - k^4)}{d^3} = \frac{(d_o)^3 (1 - k^4)}{(d_o)^3} = 1 - k^4 \quad \dots(\because d = d_o) \\ &= 1 - (0.5)^4 = 0.9375 \text{ Ans.} \end{aligned}$$

*Comparison of stiffness*

We know that stiffness

$$= \frac{T}{\theta} = \frac{G \times J}{L}$$

$\therefore$  Stiffness of a hollow shaft,

$$S_H = \frac{G}{L} \times \frac{\pi}{32} [(d_o)^4 - (d_i)^4] \quad \dots(v)$$

and stiffness of a solid shaft,

$$S_s = \frac{G}{L} \times \frac{\pi}{32} \times d^4 \quad \dots(vi)$$

Dividing equation (v) by equation (vi), we get

$$\begin{aligned} \frac{S_H}{S_s} &= \frac{(d_o)^4 - (d_i)^4}{d^4} = \frac{(d_o)^4 - (d_i)^4}{(d_o)^4} = 1 - \frac{(d_i)^4}{(d_o)^4} \quad \dots(\because d = d_o) \\ &= 1 - k^4 = 1 - (0.5)^4 = 0.9375 \text{ Ans.} \end{aligned}$$

**References:**

1. Machine Design - V.Bandari .
2. Machine Design – R.S. Khurmi
3. Design Data hand Book - S MD Jalaludin.



### **Shaft Coupling**

Shafts are usually available up to 7 meters length due to inconvenience in transport. In order to have a greater length, it becomes necessary to join two or more pieces of the shaft by means of a coupling.

Shaft couplings are used in machinery for several purposes, the most common of which are the following:

1. To provide for the connection of shafts of units those are manufactured separately such as a motor and generator and to provide for disconnection for repairs or alternations.
2. To provide for misalignment of the shafts or to introduce mechanical flexibility.
3. To reduce the transmission of shock loads from one shaft to another.
4. To introduce protection against overloads.
5. It should have no projecting parts.

### **Types of Shafts Couplings**

Shaft couplings are divided into two main groups as follows:

**1. Rigid coupling.** It is used to connect two shafts which are perfectly aligned. Following types of rigid coupling are important from the subject point of view:

- (a) Sleeve or muff coupling.
- (b) Clamp or split-muff or compression coupling, and
- (c) Flange coupling.

**2. Flexible coupling.** It is used to connect two shafts having both lateral and angular misalignment. Following types of flexible coupling are important from the subject point of view:

- (a) Bushed pin type coupling,
- (b) Universal coupling, and
- (c) Oldham coupling.

### **Sleeve or Muff-coupling**

It is the simplest type of rigid coupling, made of cast iron. It consists of a hollow cylinder whose inner diameter is the same as that of the shaft. It is fitted over the ends of the two shafts by means of a gib head key, as shown in Fig. The power is transmitted from one shaft to the other shaft by means of a key and a sleeve. It is, therefore, necessary that all the elements must be strong enough to transmit the torque. The usual proportions of a cast iron sleeve coupling are as follows:

Outer diameter of the sleeve,  $D = 2d + 13 \text{ mm}$



And length of the sleeve,  $L = 3.5 d$

Where  $d$  is the diameter of the shaft.

In designing a sleeve or muff-coupling, the following procedure may be adopted.

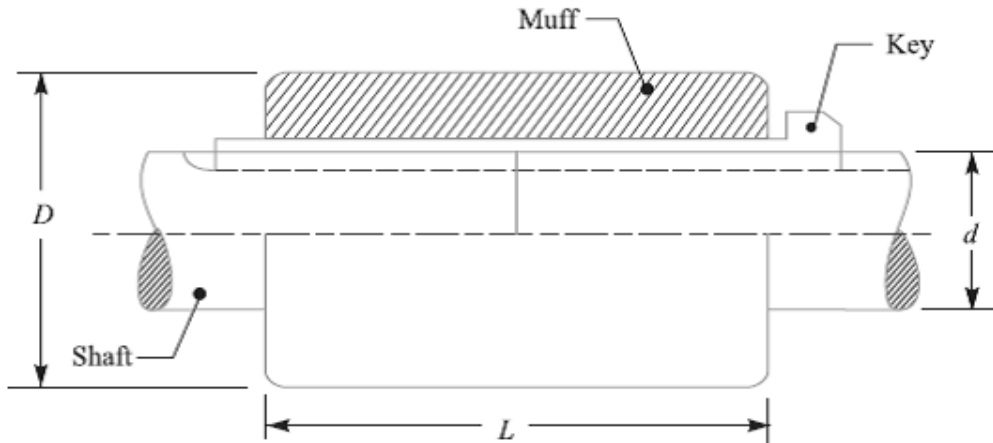

**1. Design for sleeve**

The sleeve is designed by considering it as a hollow shaft

Let  $T =$  Torque to be transmitted by the coupling, and

$\tau_c =$  Permissible shear stress for the material of the sleeve which is cast iron.

The safe value of shear stress for cast iron may be taken as 14 MPa.

We know that torque transmitted by a hollow section,

$$T = \frac{\pi}{16} \times \tau_c \left( \frac{D^4 - d^4}{D} \right) = \frac{\pi}{16} \times \tau_c \times D^3 (1 - k^4) \quad \dots (\because k = d/D)$$

From this expression, the induced shear stress in the sleeve may be checked.

**2. Design for key**

The key for the coupling may be designed in the similar way as discussed in Unit-5. The width and thickness of the coupling key is obtained from the proportions. The length of the coupling key is at least equal to the length of the sleeve (i.e.  $3.5 d$ ). The coupling key is usually made into two parts so that the length of the key in each shaft,

$$l = \frac{L}{2} = \frac{3.5 d}{2}$$

After fixing the length of key in each shaft, the induced shearing and crushing stresses may be checked. We know that torque transmitted,

$$T = l \times w \times \tau \times \frac{d}{2} \quad \dots \text{(Considering shearing of the key)}$$

$$= l \times \frac{t}{2} \times \sigma_c \times \frac{d}{2} \quad \dots \text{(Considering crushing of the key)}$$

**Note:** The depth of the keyway in each of the shafts to be connected should be exactly the same and the diameters should also be same. If these conditions are not satisfied, then the key will be bedded on one shaft while in the other it will be loose. In order to prevent this, the key is made in two parts which may be driven from the same end for each shaft or they may be driven from opposite ends.

**References:**

1. Machine Design - V.Bandari .
2. Machine Design – R.S. Khurmi
3. Design Data hand Book - S MD Jalaludin.



Problem: Design and make a neat dimensioned sketch of a muff coupling which is used to connect two steel shafts transmitting 40 kW at 350 r.p.m. The material for the shafts and key is plain carbon steel for which allowable shear and crushing stresses may be taken as 40 MPa and 80 MPa respectively. The material for the muff is cast iron for which the allowable shear stress may be assumed as 15 MPa.

**Solution.**

Given:  $P = 40 \text{ kW} = 40 \times 10^3 \text{ W}$ ;  $N = 350 \text{ r.p.m.}$ ;  $\tau_s = 40 \text{ MPa} = 40 \text{ N/mm}^2$ ;  $\sigma_{cs} = 80 \text{ MPa} = 80 \text{ N/mm}^2$ ;  $\sigma_c = 15 \text{ MPa} = 15 \text{ N/mm}^2$ .

$$T = \frac{P \times 60}{2 \pi N} = \frac{40 \times 10^3 \times 60}{2 \pi \times 350} = 1100 \text{ N-m}$$

$$= 1100 \times 10^3 \text{ N-mm}$$

We also know that the torque transmitted ( $T$ ),

$$1100 \times 10^3 = \frac{\pi}{16} \times \tau_s \times d^3 = \frac{\pi}{16} \times 40 \times d^3 = 7.86 d^3$$

$$\therefore d^3 = 1100 \times 10^3 / 7.86 = 140 \times 10^3 \text{ or } d = 52 \text{ say } 55 \text{ mm Ans.}$$

**2. Design for sleeve**

We know that outer diameter of the muff,

$$D = 2d + 13 \text{ mm} = 2 \times 55 + 13 = 123 \text{ say } 125 \text{ mm Ans.}$$

and length of the muff,

$$L = 3.5 d = 3.5 \times 55 = 192.5 \text{ say } 195 \text{ mm Ans.}$$

Let us now check the induced shear stress in the muff. Let  $\tau_c$  be the induced shear stress in the muff which is made of cast iron. Since the muff is considered to be a hollow shaft, therefore the torque transmitted ( $T$ ),

$$1100 \times 10^3 = \frac{\pi}{16} \times \tau_c \left( \frac{D^4 - d^4}{D} \right) = \frac{\pi}{16} \times \tau_c \left[ \frac{(125)^4 - (55)^4}{125} \right]$$

$$= 370 \times 10^3 \tau_c$$

$$\therefore \tau_c = 1100 \times 10^3 / 370 \times 10^3 = 2.97 \text{ N/mm}^2$$

Since the induced shear stress in the muff (cast iron) is less than the permissible shear stress of 15 N/mm<sup>2</sup>, therefore the design of muff is safe.

**3. Design for key**

From Design data Book, we find that for a shaft of 55 mm diameter,

$$\text{Width of key, } w = 18 \text{ mm Ans.}$$

Since the crushing stress for the key material is twice the shearing stress, therefore a square key may be used.

Then, Thickness of key,  $t = w = 18 \text{ mm}$  **Ans.**

We know that length of key in each shaft,

$$l = L / 2 = 195 / 2 = 97.5 \text{ mm} \text{ **Ans.**}$$

Let us now check the induced shear and crushing stresses in the key. First of all, let us consider shearing of the key. We know that torque transmitted ( $T$ ),

$$1100 \times 10^3 = l \times w \times \tau_s \times \frac{d}{2} = 97.5 \times 18 \times \tau_s \times \frac{55}{2} = 48.2 \times 10^3 \tau_s$$

$$\tau_s = 1100 \times 10^3 / 48.2 \times 10^3 = 22.8 \text{ N/mm}^2$$

Now considering crushing of the key. We know that torque transmitted ( $T$ ),

$$1100 \times 10^3 = l \times \frac{t}{2} \times \sigma_{cs} \times \frac{d}{2} = 97.5 \times \frac{18}{2} \times \sigma_{cs} \times \frac{55}{2} = 24.1 \times 10^3 \sigma_{cs}$$

$$\sigma_{cs} = 1100 \times 10^3 / 24.1 \times 10^3 = 45.6 \text{ N/mm}^2$$

Since the induced shear and crushing stresses are less than the permissible stresses, therefore the design of key is safe.

#### **References:**

1. Machine Design - V. Bandari .
2. Machine Design – R.S. Khurmi
3. Design Data hand Book - S MD Jalaludin.



**Clamp or Compression Coupling or split muff coupling**

It is also known as **split muff coupling**. In this case, the muff or sleeve is made into two halves and are bolted together as shown in Fig. The halves of the muff are made of cast iron. The shaft ends are made to a butt each other and a single key is fitted directly in the keyways of both the shafts. One-half of the muff is fixed from below and the other half is placed from above. Both the halves are held together by means of mild steel studs or bolts and nuts. The number of bolts may be two, four or six. The nuts are recessed into the bodies of the muff castings. This coupling may be used for heavy duty and moderate speeds. The advantage of this coupling is that the position of the shafts need not be changed for assembling or disassembling of the coupling. The usual proportions of the muff for the clamp or compression coupling are:

Diameter of the muff or sleeve,  $D = 2d + 13 \text{ mm}$

Length of the muff or sleeve,  $L = 3.5 d$

Where  $d$  = Diameter of the shaft.

In the clamp or compression coupling, the power is transmitted from one shaft to the other by means of key and the friction between the muff and shaft. In designing this type of coupling, the following procedure may be adopted.

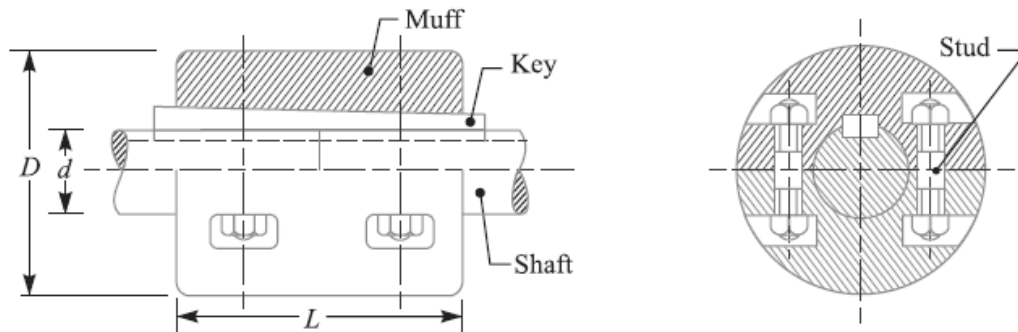

**1. Design of muff and key**

The muff and key are designed in the similar way as discussed in muff coupling.

**2. Design of clamping bolts**

Let  $T$  = Torque transmitted by the shaft,

$d$  = Diameter of shaft,

$d_b$  = Root or effective diameter of bolt,

$n$  = Number of bolts,

$\sigma_t$  = Permissible tensile stress for bolt material,

$\mu$  = Coefficient of friction between the muff and shaft, and

$L$  = Length of muff.

We know that the force exerted by each bolt

$$= \frac{\pi}{4} (d_b)^2 \sigma_t$$

Then, Force exerted by the bolts on each side of the shaft

$$= \frac{\pi}{4} (d_b)^2 \sigma_t \times \frac{n}{2}$$

Let  $p$  be the pressure on the shaft and the muff surface due to the force, then for uniform pressure distribution over the surface,

$$p = \frac{\text{Force}}{\text{Projected area}} = \frac{\frac{\pi}{4} (d_b)^2 \sigma_t \times \frac{n}{2}}{\frac{1}{2} L \times d}$$

Then, Frictional force between each shaft and muff,

$$\begin{aligned} F &= \mu \times \text{pressure} \times \text{area} = \mu \times p \times \frac{1}{2} \times \pi d \times L \\ &= \mu \times \frac{\frac{\pi}{4} (d_b)^2 \sigma_t \times \frac{n}{2}}{\frac{1}{2} L \times d} \times \frac{1}{2} \pi d \times L \\ &= \mu \times \frac{\pi}{4} (d_b)^2 \sigma_t \times \frac{n}{2} \times \pi = \mu \times \frac{\pi^2}{8} (d_b)^2 \sigma_t \times n \end{aligned}$$

And the torque that can be transmitted by the coupling,

$$T = F \times \frac{d}{2} = \mu \times \frac{\pi^2}{8} (d_b)^2 \sigma_t \times n \times \frac{d}{2} = \frac{\pi^2}{16} \times \mu (d_b)^2 \sigma_t \times n \times d$$

From this relation, the root diameter of the bolt ( $d_b$ ) may be evaluated.

### **Flange Coupling**

A flange coupling usually applies to a coupling having two separate cast iron flanges. Each flange is mounted on the shaft end and keyed to it. The faces are turned up at right angle to the axis of the shaft. One of the flanges has a projected portion and the other flange has a corresponding recess. This helps to bring the shafts into line and to maintain alignment. The two flanges are coupled together by means of bolts and nuts. The flange coupling is adapted to heavy loads and hence it is used on large shafting.

The flange couplings are of the following three types:

**1. Unprotected type flange coupling.** In an unprotected type flange coupling, as shown in Fig.1, each shaft is keyed to the boss of a flange with a counter sunk key and the flanges are coupled together by means of bolts. Generally, three, four or six bolts are used. The keys are staggered at right angle along the circumference of the shafts in order to divide the weakening effect caused by keyways.

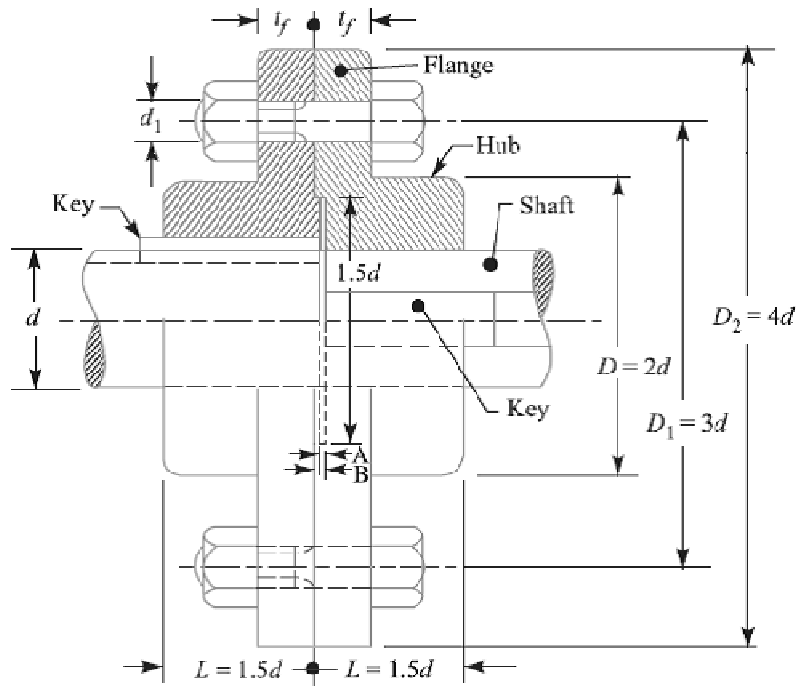

Fig.1 Unprotected Type Flange Coupling.

The usual proportions for an unprotected type cast iron flange couplings, as shown in Fig.1, are as follows:

If  $d$  is the diameter of the shaft or inner diameter of the hub, then Outside diameter of hub,

$$D = 2 d$$

Length of hub,  $L = 1.5 d$

Pitch circle diameter of bolts,  $D_1 = 3d$

Outside diameter of flange,

$$D_2 = D_1 + (D_1 - D) = 2 D_1 - D = 4 d$$

Thickness of flange,  $t_f = 0.5 d$

- Number of bolts
- = 3, for  $d$  upto 40 mm
  - = 4, for  $d$  upto 100 mm
  - = 6, for  $d$  upto 180 mm



**2. Protected type flange coupling.** In a protected type flange coupling, as shown in Fig.2, the protruding bolts and nuts are protected by flanges on the two halves of the coupling, in order to avoid danger to the workman. The thickness of the protective circumferential flange ( $t_p$ ) is taken as  $0.25 d$ . The other proportions of the coupling are same as for unprotected type flange coupling.

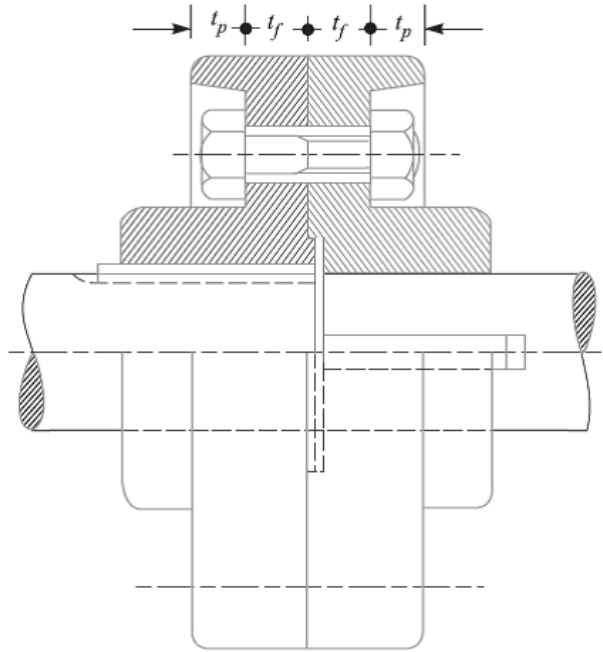

Fig.2. Protected Type Flange Coupling.

**3. Marine type flange coupling.** In a marine type flange coupling, the flanges are forged integral with the shafts as shown in Fig.3.

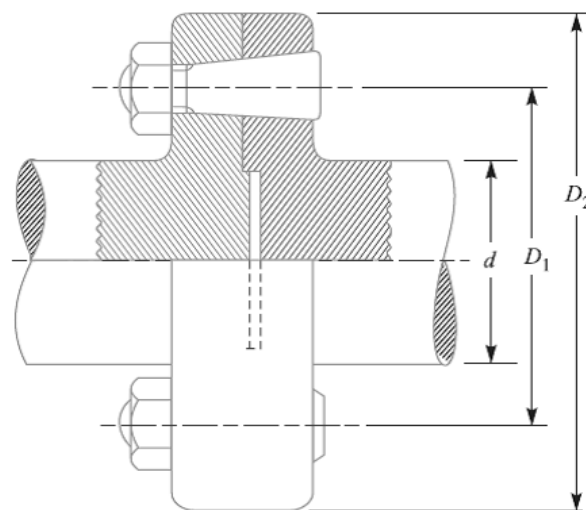

Fig.3. Solid Flange Coupling or Marine Type flange coupling.

The flanges are held together by means of tapered headless bolts, numbering from four to twelve depending upon the diameter of shaft. The other proportions for the marine type flange coupling are taken as follows:

Thickness of flange =  $d / 3$

Taper of bolt = 1 in 20 to 1 in 40

Pitch circle diameter of bolts,  $D_1 = 1.6 d$

Outside diameter of flange,  $D_2 = 2.2 d$

### **Design of Flange Coupling**

Consider a flange coupling as shown in Fig.1 and Fig.2.

Let  $d$  = Diameter of shaft or inner diameter of hub,

$D$  = Outer diameter of hub,

$D_1$  = Nominal or outside diameter of bolt,

$D_1$  = Diameter of bolt circle,

$n$  = Number of bolts,

$t_f$  = Thickness of flange,

$\tau_s$ ,  $\tau_b$  and  $\tau_k$  = Allowable shear stress for shaft, bolt and key material respectively

$\tau_c$  = Allowable shear stress for the flange material i.e. cast iron,

$\sigma_{cb}$ , and  $\sigma_{ck}$  = Allowable crushing stress for bolt and key material respectively.

The flange coupling is designed as discussed below:

#### **1. Design for hub**

The hub is designed by considering it as a hollow shaft, transmitting the same torque ( $T$ ) as that of a solid shaft.

$$T = \frac{\pi}{16} \times \tau_c \left( \frac{D^4 - d^4}{D} \right)$$

The outer diameter of hub is usually taken as twice the diameter of shaft. Therefore from the above relation, the induced shearing stress in the hub may be checked.

The length of hub ( $L$ ) is taken as  $1.5 d$ .

#### **2. Design for key**

The key is designed with usual proportions and then checked for shearing and crushing stresses. The material of key is usually the same as that of shaft. The length of key is taken equal to the length of hub.

#### **3. Design for flange**

The flange at the junction of the hub is under shear while transmitting the torque. Therefore, the torque transmitted,

$T = \text{Circumference of hub} \times \text{Thickness of flange} \times \text{Shear stress of flange} \times \text{Radius of hub}$

$$= \pi D \times t_f \times \tau_c \times \frac{D}{2} = \frac{\pi D^2}{2} \times \tau_c \times t_f$$

The thickness of flange is usually taken as half the diameter of shaft. Therefore from the above relation, the induced shearing stress in the flange may be checked.

#### 4. Design for bolts

The bolts are subjected to shear stress due to the torque transmitted. The number of bolts ( $n$ ) depends upon the diameter of shaft and the pitch circle diameter of bolts ( $D_1$ ) is taken as  $3d$ .

We know that

Load on each bolt

$$= \frac{\pi}{4} (d_1)^2 \tau_b$$

Then, Total load on all the bolts

$$= \frac{\pi}{4} (d_1)^2 \tau_b \times n$$

And torque transmitted,

$$T = \frac{\pi}{4} (d_1)^2 \tau_b \times n \times \frac{D_1}{2}$$

From this equation, the diameter of bolt ( $d_1$ ) may be obtained. Now the diameter of bolt may be checked in crushing.

We know that area resisting crushing of all the bolts =  $n \times d_1 \times t_f$

And crushing strength of all the bolts =  $(n \times d_1 \times t_f) \sigma_{cb}$

Torque,

$$T = (n \times d_1 \times t_f \times \sigma_{cb}) \frac{D_1}{2}$$

From this equation, the induced crushing stress in the bolts may be checked.

#### References:

1. Machine Design - V. Bandari .
2. Machine Design – R.S. Khurmi
3. Design Data hand Book - S MD Jalaludin.

Problem: Design a cast iron protective type flange coupling to transmit 15 kW at 900 r.p.m. from an electric motor to a compressor. The service factor may be assumed as 1.35. The following permissible stresses may be used :

Shear stress for shaft, bolt and key material = 40 MPa

Crushing stress for bolt and key = 80 MPa

Shear stress for cast iron = 8 MPa

Draw a neat sketch of the coupling.

Solution. Given:  $P = 15 \text{ kW} = 15 \times 10^3 \text{ W}$ ;  $N = 900 \text{ r.p.m.}$  ; Service factor = 1.35 ;  $\tau_s = \tau_b = \tau_k = 40 \text{ MPa} = 40 \text{ N/mm}^2$  ;  $\sigma_{cb} = \sigma_{ck} = 80 \text{ MPa} = 80 \text{ N/mm}^2$  ;  $\tau_c = 8 \text{ MPa} = 8 \text{ N/mm}^2$ .

The protective type flange coupling is designed as discussed below:

### 1. Design for hub

First of all, let us find the diameter of the shaft (d). We know that the torque transmitted by the shaft,

$$T = \frac{P \times 60}{2 \pi N} = \frac{15 \times 10^3 \times 60}{2 \pi \times 900} = 159.13 \text{ N-m}$$

Since the service factor is 1.35, therefore the maximum torque transmitted by the shaft,  $T_{\max} = 1.35 \times 159.13 = 215 \text{ N-m} = 215 \times 10^3 \text{ N-mm}$

We know that the torque transmitted by the shaft (T),

$$215 \times 10^3 = \frac{\pi}{16} \times \tau_s \times d^3 = \frac{\pi}{16} \times 40 \times d^3 = 7.86 d^3$$

$$d^3 = 215 \times 10^3 / 7.86 = 27.4 \times 10^3 \quad \text{or} \quad d = 30.1 \text{ say } 35 \text{ mm Ans.}$$

We know that outer diameter of the hub,

$$D = 2d = 2 \times 35 = 70 \text{ mm Ans.}$$

And length of hub,  $L = 1.5 d = 1.5 \times 35 = 52.5 \text{ mm Ans.}$

Let us now check the induced shear stress for the hub material which is cast iron. Considering the hub as a hollow shaft. We know that the maximum torque transmitted ( $T_{\max}$ ).

$$215 \times 10^3 = \frac{\pi}{16} \times \tau_c \left[ \frac{D^4 - d^4}{D} \right] = \frac{\pi}{16} \times \tau_c \left[ \frac{(70)^4 - (35)^4}{70} \right] = 63 \, 147 \tau_c.$$

$$\text{Then, } \tau_c = 215 \times 10^3 / 63 \, 147 = 3.4 \text{ N/mm}^2 = 3.4 \text{ MPa}$$

Since the induced shear stress for the hub material (i.e. cast iron) is less than the permissible value of 8 MPa, therefore the design of hub is safe.

### 2. Design for key

Since the crushing stress for the key material is twice its shear stress (i.e.  $\sigma_{ck} = 2\tau_k$ ), therefore a square key may be used. From DDB, we find that for a shaft of 35 mm diameter,

Width of key,  $w = 12$  mm Ans.

And thickness of key,  $t = w = 12$  mm Ans.

The length of key ( $l$ ) is taken equal to the length of hub.

Then,  $l = L = 52.5$  mm Ans.

Let us now check the induced stresses in the key by considering it in shearing and crushing.

Considering the key in shearing. We know that the maximum torque transmitted ( $T_{max}$ ),

$$215 \times 10^3 = l \times w \times \tau_k \times \frac{d}{2} = 52.5 \times 12 \times \tau_k \times \frac{35}{2} = 11\,025 \tau_k$$

Then,  $\tau_k = 215 \times 10^3 / 11\,025 = 19.5$  N/mm<sup>2</sup> = 19.5 MPa

Considering the key in crushing. We know that the maximum torque transmitted ( $T_{max}$ ),

$$215 \times 10^3 = l \times \frac{t}{2} \times \sigma_{ck} \times \frac{d}{2} = 52.5 \times \frac{12}{2} \times \sigma_{ck} \times \frac{35}{2} = 5512.5 \sigma_{ck}$$

$\sigma_{ck} = 215 \times 10^3 / 5512.5 = 39$  N/mm<sup>2</sup> = 39 MPa.

Since the induced shear and crushing stresses in the key are less than the permissible stresses, therefore the design for key is safe.

### 3. Design for flange

The thickness of flange ( $t_f$ ) is taken as 0.5 d.

Then,  $t_f = 0.5 d = 0.5 \times 35 = 17.5$  mm Ans.

Let us now check the induced shearing stress in the flange by considering the flange at the junction of the hub in shear.

We know that the maximum torque transmitted ( $T_{max}$ ),

$$215 \times 10^3 = \frac{\pi D^2}{2} \times \tau_c \times t_f = \frac{\pi (70)^2}{2} \times \tau_c \times 17.5 = 134\,713 \tau_c$$

$\tau_c = 215 \times 10^3 / 134\,713 = 1.6$  N/mm<sup>2</sup> = 1.6 MPa

Since the induced shear stress in the flange is less than 8 MPa, therefore the design of flange is safe.

### 4. Design for bolts

Let  $d_1$  = Nominal diameter of bolts.

Since the diameter of the shaft is 35 mm, therefore let us take the number of bolts,

$n = 3$  and pitch circle diameter of bolts,

$D_1 = 3d = 3 \times 35 = 105$  mm

The bolts are subjected to shear stress due to the torque transmitted. We know that the maximum torque transmitted ( $T_{\max}$ ),

$$215 \times 10^3 = \frac{\pi}{4} (d_1)^2 \tau_b \times n \times \frac{D_1}{2} = \frac{\pi}{4} (d_1)^2 40 \times 3 \times \frac{105}{2} = 4950 (d_1)^2$$

$$(d_1)^2 = 215 \times 10^3 / 4950 = 43.43 \text{ or } d_1 = 6.6 \text{ mm}$$

Assuming coarse threads, the nearest standard size of bolt is M 8. Ans.

Other proportions of the flange are taken as follows:

Outer diameter of the flange,

$$D_2 = 4 d = 4 \times 35 = 140 \text{ mm Ans.}$$

Thickness of the protective circumferential flange,

$$t_p = 0.25 d = 0.25 \times 35 = 8.75 \text{ say } 10 \text{ mm Ans.}$$

### References:

1. Machine Design - V.Bandari .
2. Machine Design – R.S. Khurmi
3. Design Data hand Book - S MD Jalaludin.



**Flexible Coupling:**

We have already discussed that a flexible coupling is used to join the abutting ends of shafts. when they are not in exact alignment. In the case of a direct coupled drive from a prime mover to an electric generator, we should have four bearings at a comparatively close distance. In such a case and in many others, as in a direct electric drive from an electric motor to a machine tool, a flexible coupling is used so as to permit an axial misalignemnt of the shaft without undue absorption of the power which the shaft are transmitting.

**Bushed-pin Flexible Coupling**

A bushed-pin flexible coupling, as shown in Fig., is a modification of the rigid type of flange coupling. The coupling bolts are known as pins.

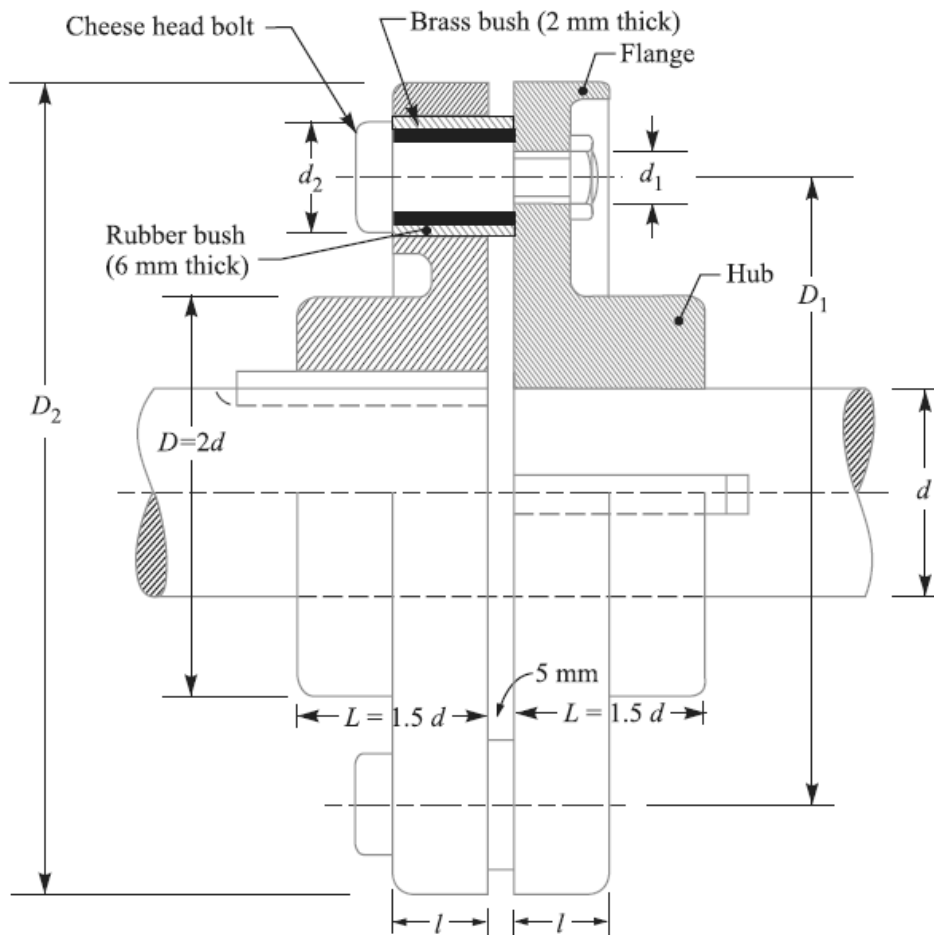

The rubber or leather bushes are used over the pins. The two halves of the coupling are dissimilar in construction. A clearance of 5 mm is left between the face of the two halves of the coupling. There is no rigid connection between them and the drive takes place through the medium of the compressible rubber or leather bushes.

In designing the bushed-pin flexible coupling, the proportions of the rigid type flange coupling are modified. The main modification is to reduce the bearing pressure on the rubber or leather bushes and it should not exceed 0.5 N/mm<sup>2</sup>. In order to keep the low bearing pressure, the pitch circle diameter and the pin size is increased.

Let  $l$  = Length of bush in the flange,

$D_2$  = Diameter of bush,

$P_b$  = Bearing pressure on the bush or pin,

$n$  = Number of pins, and

$D_1$  = Diameter of pitch circle of the pins.

We know that bearing load acting on each pin,

$$W = p_b \times d_2 \times l$$

Then, Total bearing load on the bush or pins

$$= W \times n = p_b \times d_2 \times l \times n$$

And the torque transmitted by the coupling,

$$T = W \times n \left( \frac{D_1}{2} \right) = p_b \times d_2 \times l \times n \left( \frac{D_1}{2} \right)$$

The threaded portion of the pin in the right hand flange should be a tapping fit in the coupling hole to avoid bending stresses.

The threaded length of the pin should be as small as possible so that the direct shear stress can be taken by the unthreaded neck.

Direct shear stress due to pure torsion in the coupling halves,

$$\tau = \frac{W}{\frac{\pi}{4} (d_1)^2}$$

Since the pin and the rubber or leather bush is not rigidly held in the left hand flange, therefore the tangential load ( $W$ ) at the enlarged portion will exert a bending action

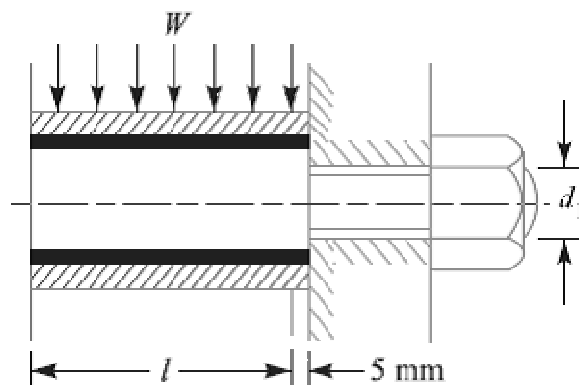

on the pin as shown in Fig. The bush portion of the pin acts as a cantilever beam of length  $l$ . Assuming a uniform distribution of the load  $W$  along the bush, the maximum bending moment on the pin,



$$M = W \left( \frac{l}{2} + 5 \text{ mm} \right)$$

We know that bending stress,

$$\sigma = \frac{M}{Z} = \frac{W \left( \frac{l}{2} + 5 \text{ mm} \right)}{\frac{\pi}{32} (d_1)^3}$$

Since the pin is subjected to bending and shear stresses, therefore the design must be checked either for the maximum principal stress or maximum shear stress by the following relations:

Maximum principal stress

$$= \frac{1}{2} \left[ \sigma + \sqrt{\sigma^2 + 4\tau^2} \right]$$

and the maximum shear stress on the pin

$$= \frac{1}{2} \sqrt{\sigma^2 + 4\tau^2}$$

The value of maximum principal stress varies from 28 to 42 MPa.

**Note:** After designing the pins and rubber bush, the hub, key and flange may be designed in the similar way as discussed for flange coupling.

**References:**

1. Machine Design - V.Bandari .
2. Machine Design – R.S. Khurmi
3. Design Data hand Book - S MD Jalaludin.



Problem:

Design a bushed-pin type of flexible coupling to connect a pump shaft to a motor shaft transmitting 32 kW at 960 r.p.m. The overall torque is 20 percent more than mean torque.

The material properties are as follows:

(a) The allowable shear and crushing stress for shaft and key material is 40 MPa and 80 MPa respectively.

(b) The allowable shear stress for cast iron is 15 MPa.

(c) The allowable bearing pressure for rubber bush is 0.8 N/mm<sup>2</sup>.

(d) The material of the pin is same as that of shaft and key.

Draw neat sketch of the coupling.

**Solution.** Given:  $P = 32 \text{ kW} = 32 \times 10^3 \text{ W}$ ;  $N = 960 \text{ r.p.m.}$ ;  $T_{\max} = 1.2 T_{\text{mean}}$ ;  $\tau_s = \tau_k = 40 \text{ MPa} = 40 \text{ N/mm}^2$ ;  $\sigma_{cs} = \sigma_{ck} = 80 \text{ MPa} = 80 \text{ N/mm}^2$ ;  $\tau_c = 15 \text{ MPa} = 15 \text{ N/mm}^2$ ;  $p_b = 0.8 \text{ N/mm}^2$ .

1. Design for pins and rubber bush

$$T_{\text{mean}} = \frac{P \times 60}{2\pi N} = \frac{32 \times 10^3 \times 60}{2\pi \times 960} = 318.3 \text{ N-m}$$

$$T_{\max} = 1.2 T_{\text{mean}} = 1.2 \times 318.3 = 382 \text{ N-m} = 382 \times 10^3 \text{ N-mm}$$

$$382 \times 10^3 = \frac{\pi}{16} \times \tau_s \times d^3 = \frac{\pi}{16} \times 40 \times d^3 = 7.86 d^3$$

$$d^3 = 382 \times 10^3 / 7.86 = 48.6 \times 10^3 \text{ or } d = 36.5 \text{ say } 40 \text{ mm}$$

$$d_1 = \frac{0.5 d}{\sqrt{n}} = \frac{0.5 \times 40}{\sqrt{6}} = 8.2 \text{ mm}$$

In order to allow for the bending stress induced due to the compressibility of the rubber bush, the diameter of the pin ( $d_1$ ) may be taken as 20 mm. Ans.

The length of the pin of least diameter i.e.  $d_1 = 20 \text{ mm}$  is threaded and secured in the right hand coupling half by a standard nut and washer. The enlarged portion of the pin which is in the left hand coupling half is made of 24 mm diameter. On the enlarged portion, a brass bush of thickness 2 mm is pressed. A brass bush carries a rubber bush. Assume the thickness of rubber bush as 6 mm.

So, Overall diameter of rubber bush,

$$d_2 = 24 + 2 \times 2 + 2 \times 6 = 40 \text{ mm} \quad \text{Ans.}$$

and diameter of the pitch circle of the pins,

$$D_1 = 2 d + d_2 + 2 \times 6 = 2 \times 40 + 40 + 12 = 132 \text{ mm} \quad \text{Ans.}$$

Let  $l$  = Length of the bush in the flange.

We know that the bearing load acting on each pin,

$$W = p_b \times d_2 \times l = 0.8 \times 40 \times l = 32 l \text{ N}$$

And the maximum torque transmitted by the coupling ( $T_{\max}$ ),

$$382 \times 10^3 = W \times n \times \frac{D_1}{2} = 32 l \times 6 \times \frac{132}{2} = 12672 l$$

$$l = 382 \times 10^3 / 12672 = 30.1 \text{ say } 32 \text{ mm}$$

And  $W = 32 l = 32 \times 32 = 1024 \text{ N}$

So, Direct stress due to pure torsion in the coupling halves,

$$\tau = \frac{W}{\frac{\pi}{4} (d_1)^2} = \frac{1024}{\frac{\pi}{4} (20)^2} = 3.26 \text{ N/mm}^2$$

Since the pin and the rubber bush are not rigidly held in the left hand flange, therefore the tangential load ( $W$ ) at the enlarged portion will exert a bending action on the pin. Assuming a uniform distribution of load ( $W$ ) along the bush, the maximum bending moment on the pin,

$$M = W \left( \frac{l}{2} + 5 \right) = 1024 \left( \frac{32}{2} + 5 \right) = 21504 \text{ N-mm}$$

$$Z = \frac{\pi}{32} (d_1)^3 = \frac{\pi}{32} (20)^3 = 785.5 \text{ mm}^3$$

$$\sigma = \frac{M}{Z} = \frac{21504}{785.5} = 27.4 \text{ N/mm}^2$$

Maximum principal stress

$$\begin{aligned} &= \frac{1}{2} \left[ \sigma + \sqrt{\sigma^2 + 4\tau^2} \right] = \frac{1}{2} \left[ 27.4 + \sqrt{(27.4)^2 + 4(3.26)^2} \right] \\ &= 13.7 + 14.1 = 27.8 \text{ N/mm}^2 \end{aligned}$$

And maximum shear stress

$$= \frac{1}{2} \left[ \sqrt{\sigma^2 + 4\tau^2} \right] = \frac{1}{2} \left[ \sqrt{(27.4)^2 + 4(3.26)^2} \right] = 14.1 \text{ N/mm}^2$$

Since the maximum principal stress and maximum shear stress are within limits, therefore the design is safe.

## 2. Design for hub

We know that the outer diameter of the hub,



We know that the maximum torque transmitted ( $T_{\max}$ ),

$$382 \times 10^3 = \frac{\pi D^2}{2} \times \tau_c \times t_f = \frac{\pi(80)^2}{2} \times \tau_c \times 20 = 201 \times 10^3 \tau_c$$

$$\tau_c = 382 \times 10^3 / 201 \times 10^3 = 1.9 \text{ N/mm}^2 = 1.9 \text{ MPa}$$

Since the induced shear stress in the flange of cast iron is less than 15 MPa, therefore the design of flange is safe.

**References:**

1. Machine Design - V.Bandari .
2. Machine Design – R.S. Khurmi
3. Design Data hand Book - S MD Jalaludin.



Problem:

Design a cast iron protective type flange coupling to transmit 15 kW at 900 r.p.m. from an electric motor to a compressor. The service factor may be assumed as 1.35. The following permissible stresses may be used:

Shear stress for shaft, bolt and key material = 40 MPa

Crushing stress for bolt and key = 80 MPa

Shear stress for cast iron = 8 MPa

Draw a neat sketch of the coupling.

**Solution.** Given:  $P = 15 \text{ kW} = 15 \times 10^3 \text{ W}$ ;  $N = 900 \text{ r.p.m.}$ ; Service factor = 1.35;  $\tau_s = \tau_b = \tau_k = 40 \text{ MPa} = 40 \text{ N/mm}^2$ ;  $\sigma_{cb} = \sigma_{ck} = 80 \text{ MPa} = 80 \text{ N/mm}^2$ ;  $\tau_c = 8 \text{ MPa} = 8 \text{ N/mm}^2$ .

The protective type flange coupling is designed as discussed below:

### 1. Design for hub

First of all, let us find the diameter of the shaft (d). We know that the torque transmitted by the shaft,

$$T = \frac{P \times 60}{2 \pi N} = \frac{15 \times 10^3 \times 60}{2 \pi \times 900} = 159.13 \text{ N-m}$$

Since the service factor is 1.35, therefore the maximum torque transmitted by the shaft,  $T_{\max} = 1.35 \times 159.13 = 215 \text{ N-m} = 215 \times 10^3 \text{ N-mm}$

We know that the torque transmitted by the shaft (T),

$$215 \times 10^3 = \frac{\pi}{16} \times \tau_s \times d^3 = \frac{\pi}{16} \times 40 \times d^3 = 7.86 d^3$$

$$d^3 = 215 \times 10^3 / 7.86 = 27.4 \times 10^3 \quad \text{or} \quad d = 30.1 \text{ say } 35 \text{ mm Ans.}$$

We know that outer diameter of the hub,

$$D = 2d = 2 \times 35 = 70 \text{ mm Ans.}$$

And length of hub,  $L = 1.5 d = 1.5 \times 35 = 52.5 \text{ mm Ans.}$

Let us now check the induced shear stress for the hub material which is cast iron. Considering the hub as a hollow shaft. We know that the maximum torque transmitted ( $T_{\max}$ ).

$$215 \times 10^3 = \frac{\pi}{16} \times \tau_c \left[ \frac{D^4 - d^4}{D} \right] = \frac{\pi}{16} \times \tau_c \left[ \frac{(70)^4 - (35)^4}{70} \right] = 63 \, 147 \tau_c.$$

$$\text{Then, } \tau_c = 215 \times 10^3 / 63 \, 147 = 3.4 \text{ N/mm}^2 = 3.4 \text{ MPa}$$

Since the induced shear stress for the hub material (i.e. cast iron) is less than the permissible value of 8 MPa, therefore the design of hub is safe.

2. Design for key

Since the crushing stress for the key material is twice its shear stress (i.e.  $\sigma_{ck} = 2\tau_k$ ), therefore a square key may be used. From DDB, we find that for a shaft of 35 mm diameter,

Width of key,  $w = 12$  mm Ans.

And thickness of key,  $t = w = 12$  mm Ans.

The length of key ( $l$ ) is taken equal to the length of hub.

Then,  $l = L = 52.5$  mm Ans.

Let us now check the induced stresses in the key by considering it in shearing and crushing.

Considering the key in shearing. We know that the maximum torque transmitted ( $T_{max}$ ),

$$215 \times 10^3 = l \times w \times \tau_k \times \frac{d}{2} = 52.5 \times 12 \times \tau_k \times \frac{35}{2} = 11\,025 \tau_k$$

Then,  $\tau_k = 215 \times 10^3 / 11\,025 = 19.5$  N/mm<sup>2</sup> = 19.5 MPa

Considering the key in crushing. We know that the maximum torque transmitted ( $T_{max}$ ),

$$215 \times 10^3 = l \times \frac{t}{2} \times \sigma_{ck} \times \frac{d}{2} = 52.5 \times \frac{12}{2} \times \sigma_{ck} \times \frac{35}{2} = 5512.5 \sigma_{ck}$$

$\sigma_{ck} = 215 \times 10^3 / 5512.5 = 39$  N/mm<sup>2</sup> = 39 MPa.

Since the induced shear and crushing stresses in the key are less than the permissible stresses, therefore the design for key is safe.

3. Design for flange

The thickness of flange ( $t_f$ ) is taken as 0.5 d.

Then,  $t_f = 0.5 d = 0.5 \times 35 = 17.5$  mm Ans.

Let us now check the induced shearing stress in the flange by considering the flange at the junction of the hub in shear.

We know that the maximum torque transmitted ( $T_{max}$ ),

$$215 \times 10^3 = \frac{\pi D^2}{2} \times \tau_c \times t_f = \frac{\pi (70)^2}{2} \times \tau_c \times 17.5 = 134\,713 \tau_c$$

$\tau_c = 215 \times 10^3 / 134\,713 = 1.6$  N/mm<sup>2</sup> = 1.6 MPa

Since the induced shear stress in the flange is less than 8 MPa, therefore the design of flange is safe.

4. Design for bolts

Let  $d_1$  = Nominal diameter of bolts.

Since the diameter of the shaft is 35 mm, therefore let us take the number of bolts,

$n = 3$  and pitch circle diameter of bolts,



$$D_1 = 3d = 3 \times 35 = 105 \text{ mm}$$

The bolts are subjected to shear stress due to the torque transmitted. We know that the maximum torque transmitted ( $T_{\max}$ ),

$$215 \times 10^3 = \frac{\pi}{4} (d_1)^2 \tau_b \times n \times \frac{D_1}{2} = \frac{\pi}{4} (d_1)^2 40 \times 3 \times \frac{105}{2} = 4950 (d_1)^2$$

$$(d_1)^2 = 215 \times 10^3 / 4950 = 43.43 \text{ or } d_1 = 6.6 \text{ mm}$$

Assuming coarse threads, the nearest standard size of bolt is M 8. Ans.

Other proportions of the flange are taken as follows:

Outer diameter of the flange,

$$D_2 = 4d = 4 \times 35 = 140 \text{ mm} \quad \text{Ans.}$$

Thickness of the protective circumferential flange,

$$t_p = 0.25d = 0.25 \times 35 = 8.75 \text{ say } 10 \text{ mm} \quad \text{Ans.}$$

### **References:**

1. Machine Design - V. Bandari .
2. Machine Design – R.S. Khurmi
3. Design Data hand Book - S MD Jalaludin.



Problem:

Two 35 mm shafts are connected by a flanged coupling. The flanges are fitted with 6 bolts on 125 mm bolt circle. The shafts transmit a torque of 800 N-m at 350 r.p.m. For the safe stresses mentioned below, calculate 1. Diameter of bolts; 2. Thickness of flanges; 3. Key dimensions ; 4. Hub length; and 5. Power transmitted. Safe shear stress for shaft material = 63 MPa Safe stress for bolt material = 56 MPa Safe stress for cast iron coupling = 10 MPa Safe stress for key material = 46 MPa

**Solution.** Given:  $d = 35 \text{ mm}$ ;  $n = 6$ ;  $D_1 = 125 \text{ mm}$ ;  $T = 800 \text{ N-m} = 800 \times 10^3 \text{ N-mm}$ ;  $N = 350 \text{ r.p.m.}$ ;  $\tau_s = 63 \text{ MPa} = 63 \text{ N/mm}^2$ ;  $\tau_b = 56 \text{ MPa} = 56 \text{ N/mm}^2$ ;  $\tau_c = 10 \text{ MPa} = 10 \text{ N/mm}^2$ ;  $\tau_k = 46 \text{ MPa} = 46 \text{ N/mm}^2$ .

### 1. Diameter of bolts

Let  $d_1$  = Nominal or outside diameter of bolt. We know that the torque transmitted ( T ),

$$800 \times 10^3 = \frac{\pi}{4} (d_1)^2 \tau_b \times n \times \frac{D_1}{2} = \frac{\pi}{4} (d_1)^2 56 \times 6 \times \frac{125}{2} = 16\,495 (d_1)^2$$

$$(d_1)^2 = 800 \times 10^3 / 16\,495 = 48.5 \text{ or } d_1 = 6.96 \text{ say } 8 \text{ mm} \quad \text{Ans.}$$

### 2. Thickness of flanges

Let  $t_f$  = Thickness of flanges.

We know that the torque transmitted (T),

$$800 \times 10^3 = \frac{\pi D^2}{2} \times \tau_c \times t_f = \frac{\pi (2 \times 35)^2}{2} \times 10 \times t_f = 76\,980 t_f \quad (\because D = 2d)$$

$$t_f = 800 \times 10^3 / 76\,980 = 10.4 \text{ say } 12 \text{ mm} \quad \text{Ans.}$$

### 3. Key dimensions

From Table 13.1, we find that the proportions of key for a 35 mm diameter shaft are:

Width of key,  $w = 12 \text{ mm}$  **Ans.**

And thickness of key,  $t = 8 \text{ mm}$  **Ans.**

The length of key (l) is taken equal to the length of hub (L).

$$l = L = 1.5 d = 1.5 \times 35 = 52.5 \text{ mm}$$

Let us now check the induced shear stress in the key. We know that the torque transmitted (T),

$$800 \times 10^3 = l \times w \times \tau_k \times \frac{d}{2} \times = 52.5 \times 12 \times \tau_k \times \frac{35}{2} = 11\,025 \tau_k$$

$$\tau_k = 800 \times 10^3 / 11\,025 = 72.5 \text{ N/mm}^2$$

Since the induced shear stress in the key is more than the given safe stress (46 MPa), therefore let us find the length of key by substituting the value of  $\tau_k = 46 \text{ MPa}$  in the above equation, i.e.

$$800 \times 10^3 = l \times 12 \times 46 \times \frac{35}{2} = 9660 l$$

$$l = 800 \times 10^3 / 9660 = 82.8 \text{ say } 85 \text{ mm Ans.}$$

#### 4. Hub length

Since the length of key is taken equal to the length of hub, therefore we shall take hub length,

$$L = l = 85 \text{ mm Ans.}$$

#### 5. Power transmitted

We know that the power transmitted,

$$P = \frac{T \times 2\pi N}{60} = \frac{800 \times 2\pi \times 350}{60} = 29\,325 \text{ W} = 29.325 \text{ kW Ans.}$$

Problem:

The shaft and the flange of a marine engine are to be designed for flange coupling, in which the flange is forged on the end of the shaft. The following particulars are to be considered in the design:

Power of the engine = 3 MW

Speed of the engine = 100 r.p.m.

Permissible shear stress in bolts and shaft = 60 MPa

Number of bolts used = 8

Pitch circle diameter of bolts = 1.6 × Diameter of shaft

Find: 1. diameter of shaft; 2. diameter of bolts; 3. thickness of flange; and 4. diameter of flange.

**Solution.** Given:  $P = 3 \text{ MW} = 3 \times 10^6 \text{ W}$ ;  $N = 100 \text{ r.p.m.}$ ;  $\tau_b = \tau_s = 60 \text{ MPa} = 60 \text{ N/mm}^2$ ;  $n = 8$ ;  $D_1 = 1.6 d$

#### 1. Diameter of shaft

Let  $d = \text{Diameter of shaft.}$

We know that the torque transmitted by the shaft,

$$T = \frac{P \times 60}{2 \pi N} = \frac{3 \times 10^6 \times 60}{2 \pi \times 100} = 286 \times 10^3 \text{ N-m} = 286 \times 10^6 \text{ N-mm}$$

We also know that torque transmitted by the shaft (T),

$$286 \times 10^6 = \frac{\pi}{16} \times \tau_s \times d^3 = \frac{\pi}{16} \times 60 \times d^3 = 11.78 d^3$$

$$d^3 = 286 \times 10^6 / 11.78 = 24.3 \times 10^6$$

$$\text{or } d = 2.89 \times 10^2 = 289 \text{ say } 300 \text{ mm Ans.}$$

## 2. Diameter of bolts

Let  $d_1$  = Nominal diameter of bolts.

The bolts are subjected to shear stress due to the torque transmitted. We know that torque transmitted (T),

$$286 \times 10^6 = \frac{\pi}{4} (d_1)^2 \tau_b \times n \times \frac{D_1}{2} = \frac{\pi}{4} \times (d_1)^2 \times 60 \times 8 \times \frac{1.6 \times 300}{2}$$

$$= 90\,490 (d_1)^2 \dots (\text{Since } D_1 = 1.6 d)$$

$$\text{So, } (d_1)^2 = 286 \times 10^6 / 90\,490 = 3160 \text{ or } d_1 = 56.2 \text{ mm}$$

Assuming coarse threads, the standard diameter of the bolt is 60 mm (M 60). The taper on the bolt may be taken from 1 in 20 to 1 in 40. **Ans.**

## 3. Thickness of flange

The thickness of flange ( $t_f$ ) is taken as  $d / 3$ .

$$\text{So, } t_f = d / 3 = 300 / 3 = 100 \text{ mm Ans.}$$

Let us now check the induced shear stress in the flange by considering the flange at the junction of the shaft in shear. We know that the torque transmitted (T),

$$286 \times 10^6 = \frac{\pi d^2}{2} \times \tau_s \times t_f = \frac{\pi (300)^2}{2} \times \tau_s \times 100 = 14.14 \times 10^6 \tau_s$$

$$\tau_s = 286 \times 10^6 / 14.14 \times 10^6 = 20.2 \text{ N/mm}^2 = 20.2 \text{ MPa}$$

Since the induced shear stress in the \*flange is less than the permissible shear stress of 60 MPa, therefore the thickness of flange ( $t_f = 100$  mm) is safe.

## 4. Diameter of flange

The diameter of flange ( $D_2$ ) is taken as 2.2 d.

$$\text{So, } D_2 = 2.2 d = 2.2 \times 300 = 660 \text{ mm Ans.}$$

## References:

1. Machine Design - V.Bandari .

2. Machine Design – R.S. Khurmi
3. Design Data hand Book - S MD Jalaludin.



**Introduction**

A spring is defined as an elastic body, whose function is to distort when loaded and to recover its original shape when the load is removed. The various important applications of springs are as follows:

1. To cushion, absorb or control energy due to either shock or vibration as in car springs, railway buffers, air-craft landing gears, shock absorbers and vibration dampers.
2. To apply forces, as in brakes, clutches and spring loaded valves.
3. To control motion by maintaining contact between two elements as in cams and followers.
4. To measure forces, as in spring balances and engine indicators.
5. To store energy, as in watches, toys, etc.

**Types of springs:**

**1. Helical springs.** The helical springs are made up of a wire coiled in the form of a helix and is primarily intended for compressive or tensile loads.

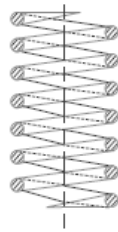

(a) Compression helical spring.



(b) Tension helical spring.

**2. Conical and volute springs.** The conical and volute springs, as shown in Fig. 23.2, are used in special applications where a telescoping spring or a spring with a spring rate that increases with the load is desired

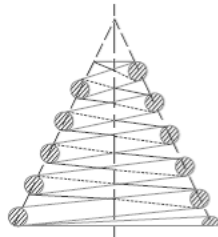

(a) Conical spring.

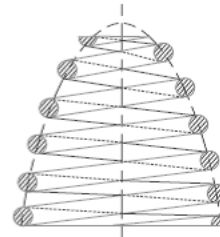

(b) Volute spring.

**3. Torsion springs.** These springs may be of **helical** or **spiral** type as shown in Fig. The **helical type** may be used only in applications where the load tends to wind up the spring and are used in various electrical mechanisms.

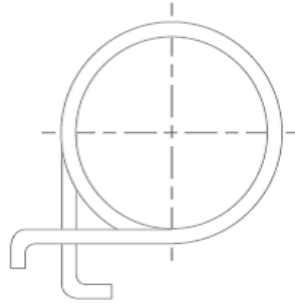

(a) Helical torsion spring.



(b) Spiral torsion spring.

**4. Laminated or leaf springs.** The laminated or leaf spring (also known as **flat spring** or **carriage spring**) consists of a number of flat plates (known as leaves) of varying lengths held together by means of clamps and bolts.

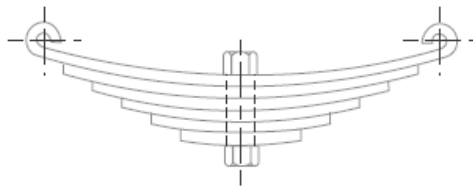

Laminated or leaf springs.

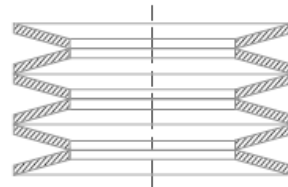

Disc or belleville springs.

**5. Disc or belleville springs.** These springs consist of a number of conical discs held together against slipping by a central bolt or tube.

**6. Special purpose springs.** These springs are air or liquid springs, rubber springs, ring springs etc. The fluids (air or liquid) can behave as a compression spring. These springs are used for special types of application only.

### Terms used in Compression Springs

**1. Solid length.** When the compression spring is compressed until the coils come in contact with each other, then the spring is said to be **solid**.

Solid length of the spring,  $L_s = n' \cdot d$  where  $n'$  = Total number of coils, and  $d$  = Diameter of the wire.

**2. Free length.** The free length of a compression spring, as shown in Fig., is the length of the spring in the free or unloaded condition.

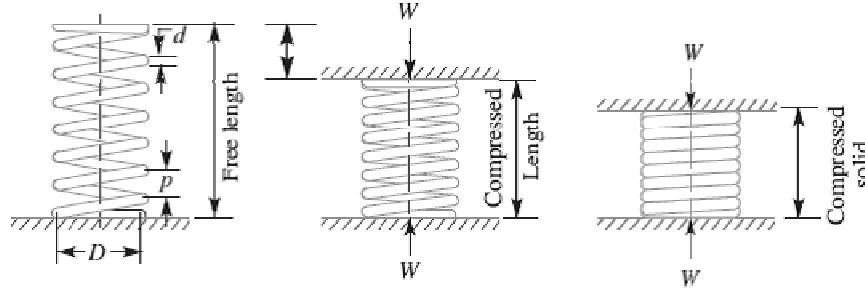

Free length of the spring,

$L_F = \text{Solid length} + \text{Maximum compression} + \text{*Clearance between adjacent coils (or clash allowance)}$

$$= n \cdot d + \delta_{\max} + 0.15 \delta_{\max}$$

**3. Spring index.** The spring index is defined as the ratio of the mean diameter of the coil to the diameter of the wire. Spring index,  $C = D / d$  where  $D = \text{Mean diameter of the coil}$ , and  $d = \text{Diameter of the wire}$ .

**4. Spring rate.** The spring rate (or stiffness or spring constant) is defined as the load required per unit deflection of the spring. Mathematically, Spring rate,  $k = W / \delta$  where  $W = \text{Load}$ , and  $\delta = \text{Deflection of the spring}$ .

**5. Pitch.** The pitch of the coil is defined as the axial distance between adjacent coils in uncompressed state. Mathematically, Pitch of the coil,

$$p = \frac{\text{Free Length}}{n - 1}$$

### Stresses in Helical Springs of Circular Wire

Consider a helical compression spring made of circular wire and subjected to an axial load  $W$ , as shown in Fig.(a).

Let  $D = \text{Mean diameter of the spring coil}$ ,

$d = \text{Diameter of the spring wire}$ ,

$n = \text{Number of active coils}$ ,

$G = \text{Modulus of rigidity for the spring material}$ ,

$W = \text{Axial load on the spring}$ ,

$\tau = \text{Maximum shear stress induced in the wire}$ ,

$C = \text{Spring index} = D/d$ ,

$p = \text{Pitch of the coils}$ , and

$\delta = \text{Deflection of the spring, as a result of an axial load } W$ .



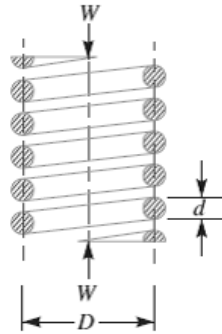

a) Axially loaded helical spring.

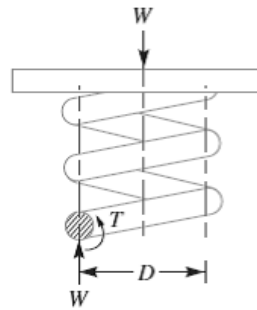

(b) Free body diagram showing that wire is subjected to torsional shear and a direct shear.

Now consider a part of the compression spring as shown in Fig. (b). The load  $W$  tends to rotate the wire due to the twisting moment ( $T$ ) set up in the wire. Thus torsional shear stress is induced in the wire.

A little consideration will show that part of the spring, as shown in Fig.(b), is in equilibrium under the action of two forces  $W$  and the twisting moment  $T$ . We know that the twisting moment,

$$T = W \times \frac{D}{2} = \frac{\pi}{16} \times \tau_1 \times d^3$$

$$\tau_1 = \frac{8W.D}{\pi d^3} \quad \dots(i)$$

The torsional shear stress diagram is shown in Fig. (a).

In addition to the torsional shear stress ( $\tau_1$ ) induced in the wire, the following stresses also act on the wire:

1. Direct shear stress due to the load  $W$ , and
2. Stress due to curvature of wire.

We know that the resultant shear stress induced in the wire,

$$\tau = \tau_1 \pm \tau_2 = \frac{8W.D}{\pi d^3} \pm \frac{4W}{\pi d^2}$$

Maximum shear stress induced in the wire,

= Torsional shear stress + Direct shear stress

$$= \frac{8W.D}{\pi d^3} + \frac{4W}{\pi d^2} = \frac{8W.D}{\pi d^3} \left( 1 + \frac{d}{2D} \right)$$

$$= \frac{8 W.D}{\pi d^3} \left(1 + \frac{1}{2C}\right) = K_S \times \frac{8 W.D}{\pi d^3} \quad \dots(iii)$$

... (Substituting  $D/d = C$ )

where  $K_S = \text{Shear stress factor} = 1 + \frac{1}{2C}$

∴ Maximum shear stress induced in the wire,

$$\tau = K \times \frac{8 W.D}{\pi d^3} = K \times \frac{8 W.C}{\pi d^2} \quad \dots(iv)$$

where  $K = \frac{4C - 1}{4C - 4} + \frac{0.615}{C}$

**Deflection of Helical Springs of Circular Wire**

Total active length of the wire,

$$l = \text{Length of one coil} \times \text{No. of active coils} = \pi D \times n$$

Let  $\theta = \text{Angular deflection of the wire when acted upon by the torque } T.$

∴ Axial deflection of the spring,

$$\delta = \theta \times D/2 \quad \dots(i)$$

We also know that

$$\frac{T}{J} = \frac{\tau}{D/2} = \frac{G.\theta}{l}$$

∴  $\theta = \frac{Tl}{J.G} \quad \dots \left( \text{considering } \frac{T}{J} = \frac{G.\theta}{l} \right)$

where  $J = \text{Polar moment of inertia of the spring wire}$

$$= \frac{\pi}{32} \times d^4, \text{ } d \text{ being the diameter of spring wire.}$$

and  $G = \text{Modulus of rigidity for the material of the spring wire.}$

Now substituting the values of  $l$  and  $J$  in the above equation, we have

$$\theta = \frac{Tl}{J.G} = \frac{\left(W \times \frac{D}{2}\right) \pi D n}{\frac{\pi}{32} \times d^4 G} = \frac{16 W.D^2 n}{G.d^4} \quad \dots(ii)$$

Substituting this value of  $\theta$  in equation (i), we have

$$\delta = \frac{16 W.D^2 n}{G.d^4} \times \frac{D}{2} = \frac{8 W.D^3 n}{G.d^4} = \frac{8 W.C^3 n}{G.d} \quad \dots (\because C = D/d)$$

and the stiffness of the spring or spring rate,

$$\frac{W}{\delta} = \frac{G.d^4}{8 D^3 n} = \frac{G.d}{8 C^3 n} = \text{constant}$$

**Buckling of Compression Springs**

It has been found experimentally that when the free length of the spring ( $L_F$ ) is more than four times the mean or pitch diameter ( $D$ ), then the spring behaves like a column and may fail by buckling at a comparatively low load.

$$W_{cr} = k \times K_B \times L_F$$

where  $k$  = Spring rate or stiffness of the spring =  $W/\delta$ ,

$L_F$  = Free length of the spring, and

$K_B$  = Buckling factor depending upon the ratio  $L_F / D$ .

### **Surge in springs**

When one end of a helical spring is resting on a rigid support and the other end is loaded suddenly, then all the coils of the spring will not suddenly deflect equally, because some time is required for the propagation of stress along the spring wire. A little consideration will show that in the beginning, the end coils of the spring in contact with the applied load takes up whole of the deflection and then it transmits a large part of its deflection to the adjacent coils. In this way, a wave of compression propagates through the coils to the supported end from where it is reflected back to the deflected end.

$$f_n = \frac{d}{2\pi D^2 \cdot n} \sqrt{\frac{6 G \cdot g}{\rho}} \text{ cycles/s}$$

Where  $d$  = Diameter of the wire,

$D$  = Mean diameter of the spring,

$n$  = Number of active turns,

$G$  = Modulus of rigidity,

$g$  = Acceleration due to gravity, and

$\rho$  = Density of the material of the spring.

### **References:**

1. Machine Design - V.Bandari .
2. Machine Design – R.S. Khurmi
3. Design Data hand Book - S MD Jalaludin.

Problem: A helical spring is made from a wire of 6 mm diameter and has outside diameter of 75 mm. If the permissible shear stress is 350 MPa and modulus of rigidity 84 kN/mm<sup>2</sup>, find the axial load which the spring can carry and the deflection per active turn.

Solution. Given :  $d = 6 \text{ mm}$  ;  $D_o = 75 \text{ mm}$  ;  $\tau = 350 \text{ MPa} = 350 \text{ N/mm}^2$  ;  $G = 84 \text{ kN/mm}^2 = 84 \times 10^3 \text{ N/mm}^2$

We know that mean diameter of the spring,

$$D = D_o - d = 75 - 6 = 69 \text{ mm}$$

∴ Spring index,  $C = \frac{D}{d} = \frac{69}{6} = 11.5$

Let  $W = \text{Axial load}$ , and  
 $\delta / n = \text{Deflection per active turn}$ .

1. *Neglecting the effect of curvature*

We know that the shear stress factor,

$$K_s = 1 + \frac{1}{2C} = 1 + \frac{1}{2 \times 11.5} = 1.043$$

and maximum shear stress induced in the wire ( $\tau$ ),

$$350 = K_s \times \frac{8W.D}{\pi d^3} = 1.043 \times \frac{8W \times 69}{\pi \times 6^3} = 0.848 W$$

∴  $W = 350 / 0.848 = 412.7 \text{ N Ans.}$

We know that deflection of the spring,

$$\delta = \frac{8W.D^3.n}{G.d^4}$$

∴ Deflection per active turn,

$$\frac{\delta}{n} = \frac{8W.D^3}{G.d^4} = \frac{8 \times 412.7 (69)^3}{84 \times 10^3 \times 6^4} = 9.96 \text{ mm Ans.}$$

2. *Considering the effect of curvature*

We know that Wahl's stress factor,

$$K = \frac{4C - 1}{4C - 4} + \frac{0.615}{C} = \frac{4 \times 11.5 - 1}{4 \times 11.5 - 4} + \frac{0.615}{11.5} = 1.123$$

We also know that the maximum shear stress induced in the wire ( $\tau$ ),

$$350 = K \times \frac{8W.C}{\pi d^2} = 1.123 \times \frac{8 \times W \times 11.5}{\pi \times 6^2} = 0.913 W$$

∴  $W = 350 / 0.913 = 383.4 \text{ N Ans.}$

and deflection of the spring,

$$\delta = \frac{8W.D^3.n}{G.d^4}$$

∴ Deflection per active turn,

$$\frac{\delta}{n} = \frac{8W.D^3}{G.d^4} = \frac{8 \times 383.4 (69)^3}{84 \times 10^3 \times 6^4} = 9.26 \text{ mm Ans.}$$

Problem: Design a spring for a balance to measure 0 to 1000 N over a scale of length 80 mm. The spring is to be enclosed in a casing of 25 mm diameter. The approximate number of turns is 30. The modulus of rigidity is 85 kN/mm<sup>2</sup>. Also calculate the maximum shear stress induced.

Solution:

*Design of spring*

Let  $D$  = Mean diameter of the spring coil,  
 $d$  = Diameter of the spring wire, and  
 $C$  = Spring index =  $D/d$ .

Since the spring is to be enclosed in a casing of 25 mm diameter, therefore the outer diameter of the spring coil ( $D_o = D + d$ ) should be less than 25 mm.

We know that deflection of the spring ( $\delta$ ),

$$80 = \frac{8 W . C^3 . n}{G . d} = \frac{8 \times 1000 \times C^3 \times 30}{85 \times 10^3 \times d} = \frac{240 C^3}{85 d}$$

$$\therefore \frac{C^3}{d} = \frac{80 \times 85}{240} = 28.3$$

Let us assume that  $d = 4$  mm. Therefore

$$C^3 = 28.3 d = 28.3 \times 4 = 113.2 \text{ or } C = 4.84$$

and  $D = C.d = 4.84 \times 4 = 19.36$  mm Ans.

We know that outer diameter of the spring coil,

$$D_o = D + d = 19.36 + 4 = 23.36 \text{ mm Ans.}$$

Since the value of  $D_o = 23.36$  mm is less than the casing diameter of 25 mm, therefore the assumed dimension,  $d = 4$  mm is correct.

*Maximum shear stress induced*

We know that Wahl's stress factor,

$$K = \frac{4C - 1}{4C - 4} + \frac{0.615}{C} = \frac{4 \times 4.84 - 1}{4 \times 4.84 - 4} + \frac{0.615}{4.84} = 1.322$$

$\therefore$  Maximum shear stress induced,

$$\begin{aligned} \tau &= K \times \frac{8 W . C}{\pi d^2} = 1.322 \times \frac{8 \times 1000 \times 4.84}{\pi \times 4^2} \\ &= 1018.2 \text{ N/mm}^2 = 1018.2 \text{ MPa Ans.} \end{aligned}$$

**References:**

1. Machine Design - V.Bandari .
2. Machine Design – R.S. Khurmi
3. Design Data hand Book - S MD Jalaludin.

Problem: Design a helical compression spring for a maximum load of 1000 N for a deflection of 25 mm using the value of spring index as 5. The maximum permissible shear stress for spring wire is 420 MPa and modulus of rigidity is 84 kN/mm<sup>2</sup>.

Take Wahl's factor,  $K = \frac{4C-1}{4C-4} + \frac{0.615}{C}$

Solution. Given :  $W = 1000 \text{ N}$  ;  $\delta = 25 \text{ mm}$  ;  $C = D/d = 5$  ;  $\tau = 420 \text{ MPa} = 420 \text{ N/mm}^2$  ;  $G = 84 \text{ kN/mm}^2 = 84 \times 10^3 \text{ N/mm}^2$

1. Mean diameter of the spring coil

Let  $D = \text{Mean diameter of the spring coil, and}$   
 $d = \text{Diameter of the spring wire.}$

We know that Wahl's stress factor,

$$K = \frac{4C-1}{4C-4} + \frac{0.615}{C} = \frac{4 \times 5 - 1}{4 \times 5 - 4} + \frac{0.615}{5} = 1.31$$

and maximum shear stress ( $\tau$ ),

$$420 = K \times \frac{8WC}{\pi d^2} = 1.31 \times \frac{8 \times 1000 \times 5}{\pi d^2} = \frac{16677}{d^2}$$

$$\therefore d^2 = 16677 / 420 = 39.7 \text{ or } d = 6.3 \text{ mm}$$

From Table 23.2, we shall take a standard wire of size SWG 3 having diameter ( $d$ ) = 6.401 mm.

$\therefore$  Mean diameter of the spring coil,

$$D = C.d = 5d = 5 \times 6.401 = 32.005 \text{ mm Ans.} \quad \dots (\because C = D/d = 5)$$

and outer diameter of the spring coil,

$$D_o = D + d = 32.005 + 6.401 = 38.406 \text{ mm Ans.}$$

2. Number of turns of the coils

Let  $n = \text{Number of active turns of the coils.}$

We know that compression of the spring ( $\delta$ ),

$$25 = \frac{8W.C^3.n}{G.d} = \frac{8 \times 1000 (5)^3 n}{84 \times 10^3 \times 6.401} = 1.86 n$$

$$\therefore n = 25 / 1.86 = 13.44 \text{ say } 14 \text{ Ans.}$$

For squared and ground ends, the total number of turns,

$$n' = n + 2 = 14 + 2 = 16 \text{ Ans.}$$

3. Free length of the spring

We know that free length of the spring

$$= n'.d + \delta + 0.15 \delta = 16 \times 6.401 + 25 + 0.15 \times 25 = 131.2 \text{ mm Ans.}$$

4. Pitch of the coil

We know that pitch of the coil

$$= \frac{\text{Free length}}{n' - 1} = \frac{131.2}{16 - 1} = 8.75 \text{ mm Ans.}$$

Problem: Design a close coiled helical compression spring for a service load ranging from 2250 N to 2750 N. The axial deflection of the spring for the load range is 6 mm. Assume a spring index of 5. The permissible shear stress intensity is 420 MPa and modulus of rigidity,  $G = 84 \text{ kN/mm}^2$ . Neglect the effect of stress concentration. Draw a fully dimensioned sketch of the spring, showing details of the finish of the end coils.

Solution. Given :  $W_1 = 2250 \text{ N}$  ;  $W_2 = 2750 \text{ N}$  ;  $\delta = 6 \text{ mm}$  ;  $C = D/d = 5$  ;  $\tau = 420 \text{ MPa} = 420 \text{ N/mm}^2$  ;  $G = 84 \text{ kN/mm}^2 = 84 \times 10^3 \text{ N/mm}^2$

1. Mean diameter of the spring coil

Let  $D =$  Mean diameter of the spring coil for a maximum load of  $W_2 = 2750 \text{ N}$ , and  $d =$  Diameter of the spring wire.

We know that twisting moment on the spring,

$$T = W_2 \times \frac{D}{2} = 2750 \times \frac{5d}{2} = 6875 d \quad \dots \left( \because C = \frac{D}{d} = 5 \right)$$

We also know that twisting moment ( $T$ ),

$$6875 d = \frac{\pi}{16} \times \tau \times d^3 = \frac{\pi}{16} \times 420 \times d^3 = 82.48 d^3$$

$$\therefore d^2 = 6875 / 82.48 = 83.35 \quad \text{or} \quad d = 9.13 \text{ mm}$$

From Table 23.2, we shall take a standard wire of size SWG 3/0 having diameter ( $d$ ) = 9.49 mm.

$\therefore$  Mean diameter of the spring coil,

$$D = 5d = 5 \times 9.49 = 47.45 \text{ mm Ans.}$$

We know that outer diameter of the spring coil,

$$D_o = D + d = 47.45 + 9.49 = 56.94 \text{ mm Ans.}$$

and inner diameter of the spring coil,

$$D_i = D - d = 47.45 - 9.49 = 37.96 \text{ mm Ans.}$$

2. Number of turns of the spring coil

Let  $n =$  Number of active turns.

It is given that the axial deflection ( $\delta$ ) for the load range from 2250 N to 2750 N (*i.e.* for  $W = 500 \text{ N}$ ) is 6 mm.

We know that the deflection of the spring ( $\delta$ ),

$$6 = \frac{8 W . C^3 . n}{G . d} = \frac{8 \times 500 (5)^3 n}{84 \times 10^3 \times 9.49} = 0.63 n$$

$$\therefore n = 6 / 0.63 = 9.5 \text{ say } 10 \text{ Ans.}$$

For squared and ground ends, the total number of turns,

$$n' = 10 + 2 = 12 \text{ Ans.}$$

3. Free length of the spring

Since the compression produced under 500 N is 6 mm, therefore maximum compression produced under the maximum load of 2750 N is

$$\delta_{max} = \frac{6}{500} \times 2750 = 33 \text{ mm}$$

We know that free length of the spring,

$$\begin{aligned} L_F &= n'.d + \delta_{max} + 0.15 \delta_{max} \\ &= 12 \times 9.49 + 33 + 0.15 \times 33 \\ &= 151.83 \text{ say } 152 \text{ mm Ans.} \end{aligned}$$

#### 4. Pitch of the coil

We know that pitch of the coil

$$= \frac{\text{Free length}}{n' - 1} = \frac{152}{12 - 1} = 13.73 \text{ say } 13.8 \text{ mm Ans.}$$

#### **References:**

1. Machine Design - V.Bandari .
2. Machine Design – R.S. Khurmi
3. Design Data hand Book - S MD Jalaludin.





**Energy Stored in Helical Springs of Circular Wire**

We know that the springs are used for storing energy which is equal to the work done on it by some external load.

Let  $W$  = Load applied on the spring, and

$\delta$  = Deflection produced in the spring due to the load  $W$ .

Assuming that the load is applied gradually, the energy stored in a spring is,

$$U = \frac{1}{2} W \cdot \delta$$

We have already discussed that the maximum shear stress induced in the spring wire,

$$\tau = K \times \frac{8 W \cdot D}{\pi d^3} \text{ or } W = \frac{\pi d^3 \cdot \tau}{8 K \cdot D}$$

We know that deflection of the spring,

$$\delta = \frac{8 W \cdot D^3 \cdot n}{G \cdot d^4} = \frac{8 \times \pi d^3 \cdot \tau}{8 K \cdot D} \times \frac{D^3 \cdot n}{G \cdot d^4} = \frac{\pi \tau \cdot D^2 \cdot n}{K \cdot d \cdot G}$$

Substituting the values of  $W$  and  $\delta$  in equation (i), we have

$$\begin{aligned} U &= \frac{1}{2} \times \frac{\pi d^3 \cdot \tau}{8 K \cdot D} \times \frac{\pi \tau \cdot D^2 \cdot n}{K \cdot d \cdot G} \\ &= \frac{\tau^2}{4 K^2 \cdot G} (\pi D \cdot n) \left( \frac{\pi}{4} \times d^2 \right) = \frac{\tau^2}{4 K^2 \cdot G} \times V \end{aligned}$$

Where  $V$  = Volume of the spring wire

= Length of spring wire  $\times$  Cross-sectional area of spring wire

**Helical Springs Subjected to Fatigue Loading**

The helical springs subjected to fatigue loading are designed by using the Soderberg line method. The spring materials are usually tested for torsional endurance strength under a repeated stress that varies from zero to a maximum. Since the springs are ordinarily loaded in one direction only (the load in springs is never reversed in nature), therefore a modified Soderberg diagram is used for springs, as shown in Fig.

The endurance limit for reversed loading is shown at point A where the mean shear stress is equal to  $\tau_e / 2$  and the variable shear stress is also equal to  $\tau_e / 2$ . A line drawn from A to B (the yield point in shear,  $\tau_y$ ) gives the Soderberg's failure stress line. If a suitable factor of safety (F.S.) is applied to the yield strength ( $\tau_y$ ), a safe stress line CD may be drawn

parallel to the line AB, as shown in Fig. Consider a design point P on the line CD. Now the value of factor of safety may be obtained as discussed below:

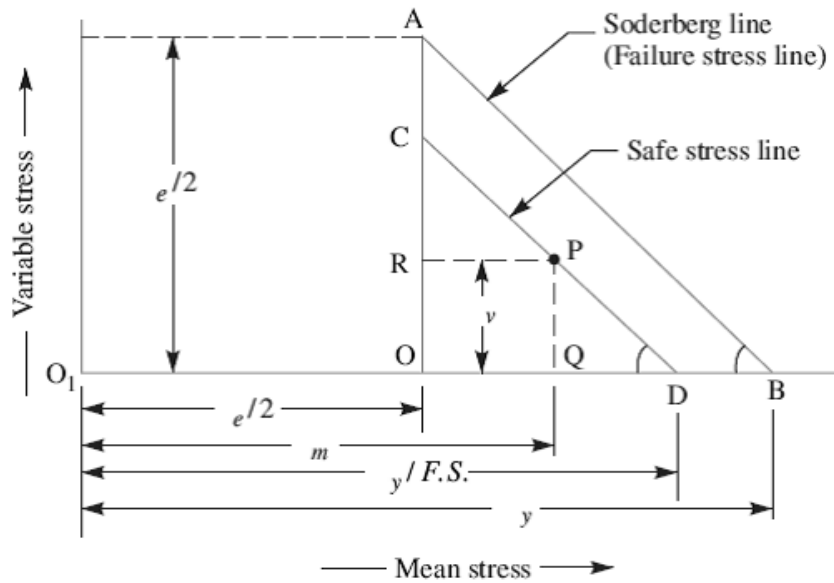

From similar triangles PQD and AOB, we have

$$\frac{PQ}{QD} = \frac{OA}{OB} \quad \text{or} \quad \frac{PQ}{O_1D - O_1Q} = \frac{OA}{O_1B - O_1O}$$

$$\frac{\tau_v}{\frac{\tau_y}{F.S.} - \tau_m} = \frac{\tau_e/2}{\tau_y - \frac{\tau_e}{2}} = \frac{\tau_e}{2\tau_y - \tau_e}$$

or 
$$2\tau_v \cdot \tau_y - \tau_v \cdot \tau_e = \frac{\tau_e \cdot \tau_y}{F.S.} - \tau_m \cdot \tau_e$$

$$\therefore \frac{\tau_e \cdot \tau_y}{F.S.} = 2\tau_v \cdot \tau_y - \tau_v \cdot \tau_e + \tau_m \cdot \tau_e$$

Dividing both sides by  $\tau_e \cdot \tau_y$  and rearranging, we have

$$\frac{1}{F.S.} = \frac{\tau_m - \tau_v}{\tau_y} + \frac{2\tau_v}{\tau_e}$$

**Springs in Series**

Total deflection of the springs,

$$\delta = \delta_1 + \delta_2$$

$$\frac{W}{k} = \frac{W}{k_1} + \frac{W}{k_2}$$

$$\frac{1}{k} = \frac{1}{k_1} + \frac{1}{k_2}$$

$k$  = Combined stiffness of the springs.

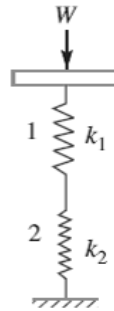

**Springs in Parallel**

$$W = W_1 + W_2$$

$$\delta k = \delta.k_1 + \delta.k_2$$

$$k = k_1 + k_2$$

$k$  = Combined stiffness of the springs, and

$\delta$  = Deflection produced.

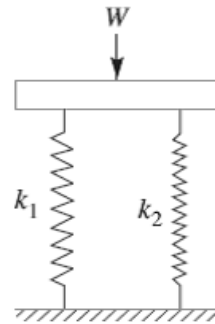

**Surge in Springs or finding natural frequency of a helical spring:**

When one end of a helical spring is resting on a rigid support and the other end is loaded suddenly, then all the coils of the spring will not suddenly deflect equally, because some time is required for the propagation of stress along the spring wire. A little consideration will show that in the beginning, the end coils of the spring in contact with the applied load takes up whole of the deflection and then it transmits a large part of its deflection to the adjacent coils. In this way, a wave of compression propagates through the coils to the supported end from where it is reflected back to the deflected end.

This wave of compression travels along the spring indefinitely. If the applied load is of fluctuating type as in the case of valve spring in internal combustion engines and if the time interval between the load applications is equal to the time required for the wave to travel from one end to the other end, then resonance will occur. This results in very large deflections of the coils and correspondingly very high stresses. Under these conditions, it is just possible that the spring may fail. This phenomenon is called *surge*.

It has been found that the natural frequency of spring should be at least twenty times the frequency of application of a periodic load in order to avoid resonance with all harmonic frequencies up to twentieth order. The natural frequency for springs clamped between two plates is given by

$$f_n = \frac{d}{2\pi D^2 \cdot n} \sqrt{\frac{6 G \cdot g}{\rho}} \text{ cycles/s}$$

Where  $d$  = Diameter of the wire,

$D$  = Mean diameter of the spring,

$n$  = Number of active turns,

$G$  = Modulus of rigidity,

$g$  = Acceleration due to gravity, and

$\rho$  = Density of the material of the spring.

The surge in springs may be eliminated by using the following methods:

1. By using friction dampers on the centre coils so that the wave propagation dies out.
2. By using springs of high natural frequency.
3. By using springs having pitch of the coils near the ends different than at the centre to have different natural frequencies.

**References:**

1. Machine Design - V.Bandari .
2. Machine Design – R.S. Khurmi
3. Design Data hand Book - S MD Jalaludin.



**Energy Stored in Helical Springs of Circular Wire**

We know that the springs are used for storing energy which is equal to the work done on it by some external load.

Let  $W$  = Load applied on the spring, and

$\delta$  = Deflection produced in the spring due to the load  $W$ .

Assuming that the load is applied gradually, the energy stored in a spring is,

$$U = \frac{1}{2} W . \delta$$

We have already discussed that the maximum shear stress induced in the spring wire,

$$\tau = K \times \frac{8 W . D}{\pi d^3} \text{ or } W = \frac{\pi d^3 . \tau}{8 K . D}$$

We know that deflection of the spring,

$$\delta = \frac{8 W . D^3 . n}{G . d^4} = \frac{8 \times \pi d^3 . \tau}{8 K . D} \times \frac{D^3 . n}{G . d^4} = \frac{\pi \tau . D^2 . n}{K . d . G}$$

Substituting the values of  $W$  and  $\delta$  in equation (i), we have

$$\begin{aligned} U &= \frac{1}{2} \times \frac{\pi d^3 . \tau}{8 K . D} \times \frac{\pi \tau . D^2 . n}{K . d . G} \\ &= \frac{\tau^2}{4 K^2 . G} (\pi D . n) \left( \frac{\pi}{4} \times d^2 \right) = \frac{\tau^2}{4 K^2 . G} \times V \end{aligned}$$

Where  $V$  = Volume of the spring wire

= Length of spring wire  $\times$  Cross-sectional area of spring wire

**Helical Torsion Springs**

The helical torsion springs as shown in Fig., may be made from round, rectangular or square wire. These are wound in a similar manner as helical compression or tension springs but the ends are shaped to transmit torque. The primary stress in helical torsion springs is bending stress whereas in compression or tension springs, the stresses are torsional shear stresses. The helical torsion springs are widely used for transmitting small torques as in door hinges, brush holders in electric motors, automobile starters etc. A little consideration will show that the radius of curvature of the coils changes when the twisting moment is applied to the spring. Thus, the wire is under pure bending. According to A.M. Wahl, the bending stress in a helical torsion spring made of round wire is

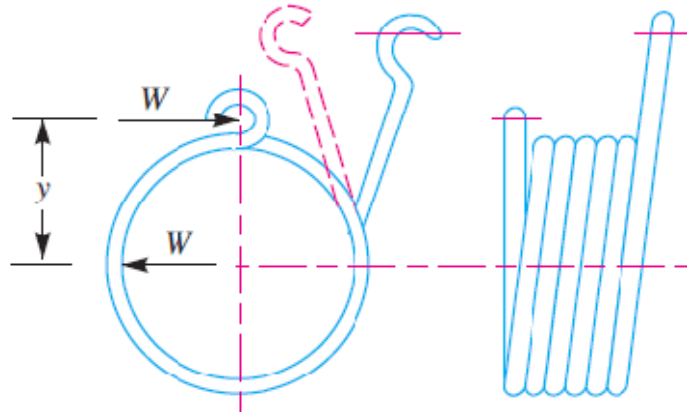

$$\sigma_b = K \times \frac{32 M}{\pi d^3} = K \times \frac{32 W \cdot y}{\pi d^3}$$

Where  $K = \text{Wahl's stress factor} = \frac{4C^2 - C - 1}{4C^2 - 4C}$

$C = \text{Spring index,}$

$M = \text{Bending moment} = W \times y,$

$W = \text{Load acting on the spring,}$

$y = \text{Distance of load from the spring axis, and}$

$d = \text{Diameter of spring wire.}$

And

Total angle of twist or angular deflection,

$$*\theta = \frac{M \cdot l}{E \cdot I} = \frac{M \times \pi D \cdot n}{E \times \pi d^4 / 64} = \frac{64 M \cdot D \cdot n}{E \cdot d^4}$$

Where  $l = \text{Length of the wire} = \pi \cdot D \cdot n,$

$E = \text{Young's modulus,} = \frac{\pi}{64} d^4$

$D = \text{Diameter of the spring, and}$

$n = \text{Number of turns.}$

And deflection,

$$\delta = \theta \times y = \frac{64 M \cdot D \cdot n}{E \cdot d^4} \times y$$

When the spring is made of rectangular wire having width  $b$  and thickness  $t$ , then

$$\sigma_b = K \times \frac{6 M}{t \cdot b^2} = K \times \frac{6 W \times y}{t \cdot b^2}$$

Where

$$K = \frac{3C^2 C 0.8}{3C^2 - 3C}$$

Angular deflection,

$$\theta = \frac{12 \pi M.D.n}{E.t.b^3}; \text{ and } \delta = \theta.y = \frac{12 \pi M.D.n}{E.t.b^3} \times y$$

In case the spring is made of square wire with each side equal to  $b$ , then substituting  $t = b$ , in the above relation, we have

$$\sigma_b = K \times \frac{6M}{b^3} = K \times \frac{6W \times y}{b^3}$$

$$\theta = \frac{12 \pi M.D.n}{E.b^4}; \text{ and } \delta = \frac{12 \pi M.D.n}{E.b^4} \times y$$

**Flat Spiral Spring**

A flat spring is a long thin strip of elastic material wound like a spiral as shown in Fig. These springs are frequently used in watches and gramophones etc. When the outer or inner end of this of spring is wound up in such a way that there is a tendency in the increase of number of spirals of the spring, the strain energy is stored into its spirals. energy is utilised in any useful way while the spirals out slowly. Usually the inner end of spring is clamped to an arbor while the outer end may be pinned or clamped. Since the radius of curvature of every spiral decreases when the spring is wound up, therefore the material of the spring is in a state of pure bending.

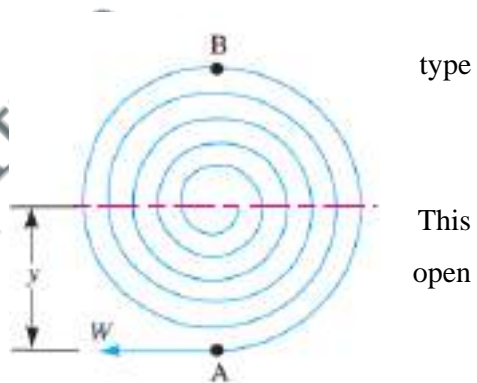

- Let  $W$  = Force applied at the outer end  $A$  of the spring,
- $y$  = Distance of centre of gravity of the spring from  $A$ ,
- $l$  = Length of strip forming the spring,
- $b$  = Width of strip,
- $t$  = Thickness of strip,
- $I$  = Moment of inertia of the spring section =  $b.t^3/12$ , and
- $Z$  = Section modulus of the spring section =  $b.t^2/6$

When the end  $A$  of the spring is pulled up by a force  $W$ , then the bending moment on the spring, at a distance  $y$  from the line of action of  $W$  is given by

$$M = W \times y$$

The greatest bending moment occurs in the spring at  $B$  which is at a maximum distance from the application of  $W$ .

Bending moment at  $B$ ,

$$M_B = M_{max} = W \times 2y = 2W.y = 2M$$

Maximum bending stress induced in the spring material,

$$\sigma_b = \frac{M_{max}}{Z} = \frac{2W \times y}{b.t^2 / 6} = \frac{12W.y}{b.t^2} = \frac{12M}{b.t^2}$$

Assuming that both ends of the spring are clamped, the angular deflection (in radians) of the spring is given by

$$\theta = \frac{M.l}{E.I} = \frac{12 M.l}{E.b.t^3}$$

And the deflection,

$$\begin{aligned} \delta &= \theta \times y = \frac{M.l.y}{E.I} \\ &= \frac{12 M.l.y}{E.b.t^3} = \frac{12W.y^2.l}{E.b.t^3} = \frac{\sigma_b.y.l}{E.t} \end{aligned}$$

The strain energy stored in the spring

$$\begin{aligned} &= \frac{1}{2} M.\theta = \frac{1}{2} M \times \frac{M.l}{E.I} = \frac{1}{2} \times \frac{M^2.l}{E.I} \\ &= \frac{1}{2} \times \frac{W^2.y^2.l}{E \times b.t^3 / 12} = \frac{6 W^2.y^2.l}{E.b.t^3} \\ &= \frac{6 W^2.y^2.l}{E.b.t^3} \times \frac{24bt}{24bt} = \frac{144 W^2.y^2}{Eb^2t^4} \times \frac{btl}{24} \\ &\quad \dots \text{(Multiplying the numerator and denominator by } 24 bt) \\ &= \frac{(\sigma_b)^2}{24 E} \times btl = \frac{(\sigma_b)^2}{24 E} \times \text{Volume of the spring} \end{aligned}$$

**References:**

1. Machine Design - V.Bandari .
2. Machine Design – R.S. Khurmi
3. Design Data hand Book - S MD Jalaludin.



**Problem:** A helical torsion spring of mean diameter 60 mm is made of a round wire of 6 mm diameter. If a torque of 6 N-m is applied on the spring, find the bending stress induced and the angular deflection of the spring in degrees. The spring index is 10 and modulus of elasticity for the spring material is 200 kN/mm<sup>2</sup>. The number of effective turns may be taken as 5.5.

**Solution.** Given :  $D = 60 \text{ mm}$  ;  $d = 6 \text{ mm}$  ;  $M = 6 \text{ N-m} = 6000 \text{ N-mm}$  ;  $C = 10$  ;  $E = 200 \text{ kN/mm}^2 = 200 \times 10^3 \text{ N/mm}^2$  ;  $n = 5.5$

**Bending stress induced**

We know that Wahl's stress factor for a spring made of round wire,

$$K = \frac{4C^2 - C - 1}{4C^2 - 4C} = \frac{4 \times 10^2 - 10 - 1}{4 \times 10^2 - 4 \times 10} = 1.08$$

∴ Bending stress induced,

$$\sigma_b = K \times \frac{32 M}{\pi d^3} = 1.08 \times \frac{32 \times 6000}{\pi \times 6^3} = 305.5 \text{ N/mm}^2 \text{ or MPa Ans.}$$

**Angular deflection of the spring**

We know that the angular deflection of the spring (in radians),

$$\begin{aligned} \theta &= \frac{64 M.D.n}{E.d^4} = \frac{64 \times 6000 \times 60 \times 5.5}{200 \times 10^3 \times 6^4} = 0.49 \text{ rad} \\ &= 0.49 \times \frac{180}{\pi} = 28^\circ \text{ Ans.} \end{aligned}$$

**Problem:** A spiral spring is made of a flat strip 6 mm wide and 0.25 mm thick. The length of the strip is 2.5 metres. Assuming the maximum stress of 800 MPa to occur at the point of greatest bending moment, calculate the bending moment, the number of turns to wind up the spring and the strain energy stored in the spring. Take  $E = 200 \text{ kN/mm}^2$ .

**Bending moment in the spring**

Let  $M =$  Bending moment in the spring.

We know that the maximum bending stress in the spring material ( $\sigma_b$ ),

$$800 = \frac{12 M}{b.t^2} = \frac{12 M}{8 (0.25)^2} = 32 M$$

∴  $M = 800 / 32 = 25 \text{ N-mm Ans.}$

**Number of turns to wind up the spring**

We know that the angular deflection of the spring,

$$\theta = \frac{12 M.l}{E.b.t^3} = \frac{12 \times 25 \times 2500}{200 \times 10^3 \times 6 (0.25)^3} = 40 \text{ rad}$$

Since one turn of the spring is equal to  $2\pi$  radians, therefore number of turns to wind up the spring

$$= 40 / 2\pi = 6.36 \text{ turns Ans.}$$

*Strain energy stored in the spring*

We know that strain energy stored in the spring

$$= \frac{1}{2} M.\theta = \frac{1}{2} \times 24 \times 40 = 480 \text{ N-mm Ans.}$$

**References:**

1. Machine Design - V.Bandari .
2. Machine Design – R.S. Khurmi
3. Design Data hand Book - S MD Jalaludin.





**Concentric or Composite Springs or coaxial springs or nested springs**

A concentric or composite spring is used for one of the following purposes:

1. To obtain greater spring force within a given space.
2. To insure the operation of a mechanism in the event of failure of one of the springs.

The concentric springs for the above two purposes may have two or more springs and have the same free lengths as shown in Fig. (a) And are compressed equally.

Such springs are used in automobile clutches; valve springs in aircraft, heavy duty diesel engines and rail-road car suspension systems. Sometimes concentric springs are used to obtain a spring force which does not increase in a direct relation to the deflection but increases faster. Such springs are made of different lengths as shown in Fig. (b). The shorter spring begins to act only after the longer spring is compressed to a certain amount. These springs are used in governors of variable speed engines to take care of the variable centrifugal force. The adjacent coils of the concentric spring are wound in opposite directions to eliminate any tendency to bind.

If the same material is used, the concentric springs are designed for the same stress. In order to get the same stress factor ( $K$ ), it is desirable to have the same spring index ( $C$ ).

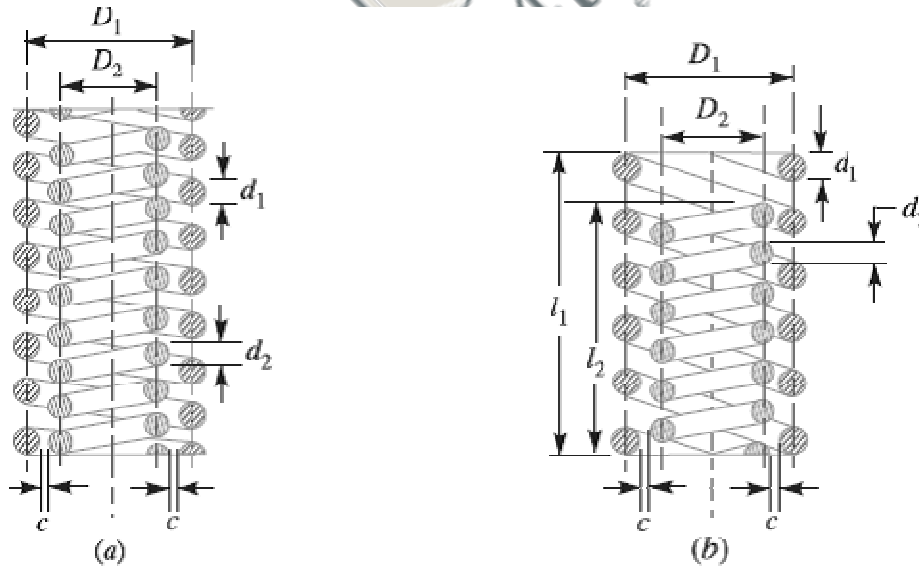

Consider a concentric spring as shown in Fig. (a).

Let  $W$  = Axial load,

$W_1$  = Load shared by outer spring,

$W_2$  = Load shared by inner spring,

$d_1$  = Diameter of spring wire of outer spring,

$d_2$  = Diameter of spring wire of inner spring,

$D_1$  = Mean diameter of outer spring,

$D_2$  = Mean diameter of inner spring,

$\delta_1$  = Deflection of outer spring,

$\delta_2$  = Deflection of inner spring,

$n_1$  = Number of active turns of outer spring, and

$n_2$  = Number of active turns of inner spring.

Assuming that both the springs are made of same material, then the maximum shear stress induced in both the springs is approximately same, *i.e.*

$$\tau_1 = \tau_2$$

$$\frac{8 W_1 \cdot D_1 \cdot K_1}{\pi (d_1)^3} = \frac{8 W_2 \cdot D_2 \cdot K_2}{\pi (d_2)^3}$$

When stress factor,  $K_1 = K_2$ , then

$$\frac{W_1 \cdot D_1}{(d_1)^3} = \frac{W_2 \cdot D_2}{(d_2)^3}$$

If both the springs are effective throughout their working range, then their free length and deflection are equal, *i.e.*

$$\delta_1 = \delta_2$$

$$\frac{8W_1 (D_1)^3 n_1}{(d_1)^4 G} = \frac{8W_2 (D_2)^3 n_2}{(d_2)^4 G} \quad \text{or} \quad \frac{W_1 (D_1)^3 n_1}{(d_1)^4} = \frac{W_2 (D_2)^3 n_2}{(d_2)^4} \quad \dots(ii)$$

When both the springs are compressed until the adjacent coils meet, then the solid length of both the springs is equal, *i.e.*

$$n_1 \cdot d_1 = n_2 \cdot d_2$$

The equation (ii) may be written as

$$\frac{W_1 (D_1)^3}{(d_1)^5} = \frac{W_2 (D_2)^3}{(d_2)^5} \quad \dots(iii)$$

Now dividing equation (iii) by equation (i), we have

$$\frac{(D_1)^2}{(d_1)^2} = \frac{(D_2)^2}{(d_2)^2} \quad \text{or} \quad \frac{D_1}{d_1} = \frac{D_2}{d_2} = C, \quad \text{the spring index} \quad \dots(iv)$$

*i.e.* the springs should be designed in such a way that the spring index for both the springs is same. From equations (i) and (iv), we have

$$\frac{W_1}{(d_1)^2} = \frac{W_2}{(d_2)^2} \quad \text{or} \quad \frac{W_1}{W_2} = \frac{(d_1)^2}{(d_2)^2} \quad \dots(v)$$

From Fig. 23.22 (a), we find that the radial clearance between the two springs,

$$*c = \left( \frac{D_1}{2} - \frac{D_2}{2} \right) - \left( \frac{d_1}{2} + \frac{d_2}{2} \right)$$

Usually, the radial clearance between the two springs is taken as

$$\frac{d_1 - d_2}{2}$$

$$\therefore \left( \frac{D_1}{2} - \frac{D_2}{2} \right) - \left( \frac{d_1}{2} + \frac{d_2}{2} \right) = \frac{d_1 - d_2}{2}$$

or  $\frac{D_1 - D_2}{2} = d_1$  ----- (vi)

From equation (iv), we find that

$$D_1 = C.d_1, \text{ and } D_2 = C.d_2$$

Substituting the values of  $D_1$  and  $D_2$  in equation (vi), we have

$$\frac{C.d_1 - C.d_2}{2} = d_1 \text{ or } C.d_1 - 2 d_1 = C.d_2$$

$$d_1 (C - 2) = C.d_2 \text{ or } \frac{d_1}{d_2} = \frac{C}{C - 2}$$

**Leaf Springs**

Leaf springs (also known as **flat springs**) are made out of flat plates. The advantage of leaf spring over helical spring is that the ends of the spring may be guided along a definite path as it deflects to act as a structural member in addition to energy absorbing device. Thus the leaf springs may carry lateral loads, brake torque, driving torque etc., in addition to shocks. Consider a single plate fixed at one end and loaded at the other end as shown in Fig. This plate may be used as a flat spring.

Let  $t$  = Thickness of plate,  
 $b$  = Width of plate, and  
 $L$  = Length of plate or distance of the load from the cantilever end.

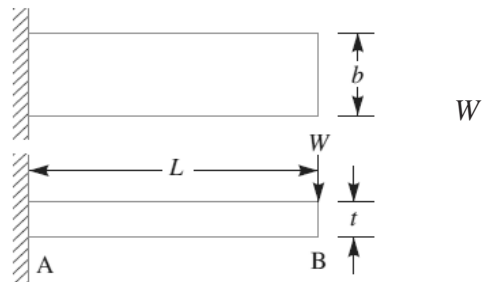

We know that the maximum bending moment at the cantilever end A,

$$M = W.L$$

And section modulus,

$$Z = \frac{I}{y} = \frac{b t^3 / 12}{t / 2} = \frac{1}{6} \times b t^2$$

Bending stress in such a spring,

$$\sigma = \frac{M}{Z} = \frac{W.L}{\frac{1}{6} \times b.t^2} = \frac{6 W.L}{b.t^2}$$

We know that the maximum deflection for a cantilever with concentrated load at the free end is given by

$$\delta = \frac{W.L^3}{3EI} = \frac{W.L^3}{3E \times b.t^3 / 12} = \frac{4 W.L^3}{E.b.t^3}$$

$$= \frac{2 \sigma.L^2}{3 E.t}$$

If the spring is not of cantilever type but it is like a simply supported beam, with length  $2L$  and load  $2W$  in the centre, as shown in Fig. then Maximum bending moment in the centre,

$$M = W.L$$

Section modulus,  $Z = b.t^2 / 6$

Bending stress,

$$\sigma = \frac{M}{Z} = \frac{W.L}{b.t^2 / 6}$$

$$= \frac{6 W.L}{b.t^2}$$

We know that maximum deflection of a simply supported beam loaded in the centre is given by

$$\delta = \frac{W_1 (L_1)^3}{48 E.I} = \frac{(2W) (2L)^3}{48 E.I} = \frac{W.L^3}{3 E.I}$$

From above we see that a spring such as automobile spring (semi-elliptical spring) with length  $2L$  and loaded in the centre by a load  $2W$ , may be treated as a double cantilever. If the plate of cantilever is cut into a series of  $n$  strips of width  $b$  and these are placed as shown in Fig., then equations (i) and (ii) may be written as

$$\sigma = \frac{6 W.L}{n.b.t^2} \quad \dots(iii)$$

And 
$$\delta = \frac{4 W.L^3}{n.E.b.t^3} = \frac{2 \sigma.L^2}{3 E.t} \quad \dots(iv)$$

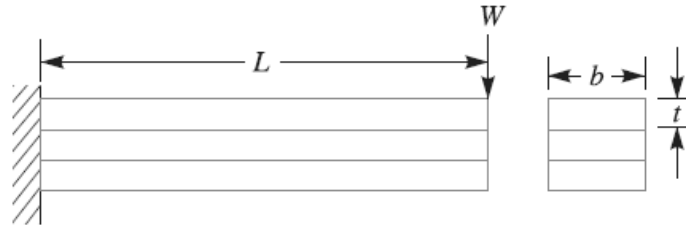

The above relations give the stress and deflection of a leaf spring of uniform cross section. The stress at such a spring is maximum at the support.

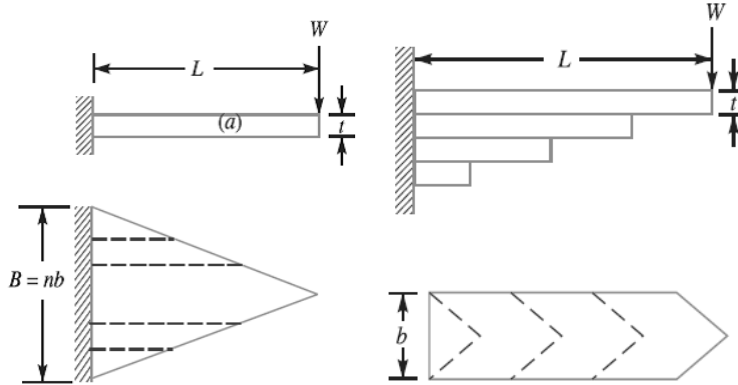

If a triangular plate is used as shown in Fig., the stress will be uniform throughout. If this triangular plate is cut into strips of uniform width and placed one below the other, as shown in Fig. to form a graduated or laminated leaf spring, then

$$\sigma = \frac{6 W.L}{n.b.t^2} \quad \dots(v)$$

$$\delta = \frac{6 W.L^3}{n.E.b.t^3} = \frac{\sigma.L^2}{E.t} \quad \dots(vi)$$

where  $n$  = Number of graduated leaves.

A little consideration will show that by the above arrangement, the spring becomes compact so that the space occupied by the spring is considerably reduced.

When bending stress alone is considered, the graduated leaves may have zero width at the loaded end. But sufficient metal must be provided to support the shear. Therefore, it becomes necessary to have one or more leaves of uniform cross-section extending clear to the end. We see from equations (iv) and (vi) that for the same deflection, the stress in the uniform cross-section leaves (*i.e.* full length leaves) is 50% greater than in the graduated leaves, assuming that each spring element deflects according to its own elastic curve. If the suffixes



F and G are used to indicate the full length (or uniform cross section) and graduated leaves, then

$$\sigma_F = \frac{3}{2} \sigma_G$$

$$\frac{6 W_F . L}{n_F . b . t^2} = \frac{3}{2} \left[ \frac{6 W_G . L}{n_G . b . t^2} \right] \quad \text{or} \quad \frac{W_F}{n_F} = \frac{3}{2} \times \frac{W_G}{n_G}$$

$$\frac{W_F}{W_G} = \frac{3 n_F}{2 n_G} \quad \dots(vii)$$

Adding 1 to both sides, we have

$$\frac{W_F}{W_G} + 1 = \frac{3 n_F}{2 n_G} + 1 \quad \text{or} \quad \frac{W_F + W_G}{W_G} = \frac{3 n_F + 2 n_G}{2 n_G}$$

$$W_G = \left( \frac{2 n_G}{3 n_F + 2 n_G} \right) (W_F + W_G) = \left( \frac{2 n_G}{3 n_F + 2 n_G} \right) W \quad \dots(viii)$$

where  $W$  = Total load on the spring =  $W_G + W_F$

$W_G$  = Load taken up by graduated leaves, and

$W_F$  = Load taken up by full length leaves.

From equation (vii), we may write

$$\frac{W_G}{W_F} = \frac{2 n_G}{3 n_F}$$

$$\text{or} \quad \frac{W_G}{W_F} + 1 = \frac{2 n_G}{3 n_F} + 1$$

$$\frac{W_G + W_F}{W_F} = \frac{2 n_G + 3 n_F}{3 n_F}$$

$$\therefore W_F = \left( \frac{3 n_F}{2 n_G + 3 n_F} \right) (W_G + W_F) = \left( \frac{3 n_F}{2 n_G + 3 n_F} \right) W \quad \dots(ix)$$

Bending stress for full length leaves,

$$\sigma_F = \frac{6 W_F . L}{n_F . b . t^2} = \frac{6 L}{n_F . b . t^2} \left( \frac{3 n_F}{2 n_G + 3 n_F} \right) W = \frac{18 W . L}{b . t^2 (2 n_G + 3 n_F)}$$

Since

$$\sigma_F = \frac{3}{2} \sigma_G, \text{ therefore}$$

$$\sigma_G = \frac{2}{3} \sigma_F = \frac{2}{3} \times \frac{18 W . L}{b . t^2 (2 n_G + 3 n_F)} = \frac{12 W . L}{b . t^2 (2 n_G + 3 n_F)}$$

The deflection in full length and graduated leaves is given by equation (iv), i.e.

$$\delta = \frac{2 \sigma_F \times L^2}{3 E.t} = \frac{2 L^2}{3 E.t} \left[ \frac{18 W.L}{b.t^2 (2 n_G + 3 n_F)} \right] = \frac{12 W.L^3}{E.b.t^3 (2 n_G + 3 n_F)}$$

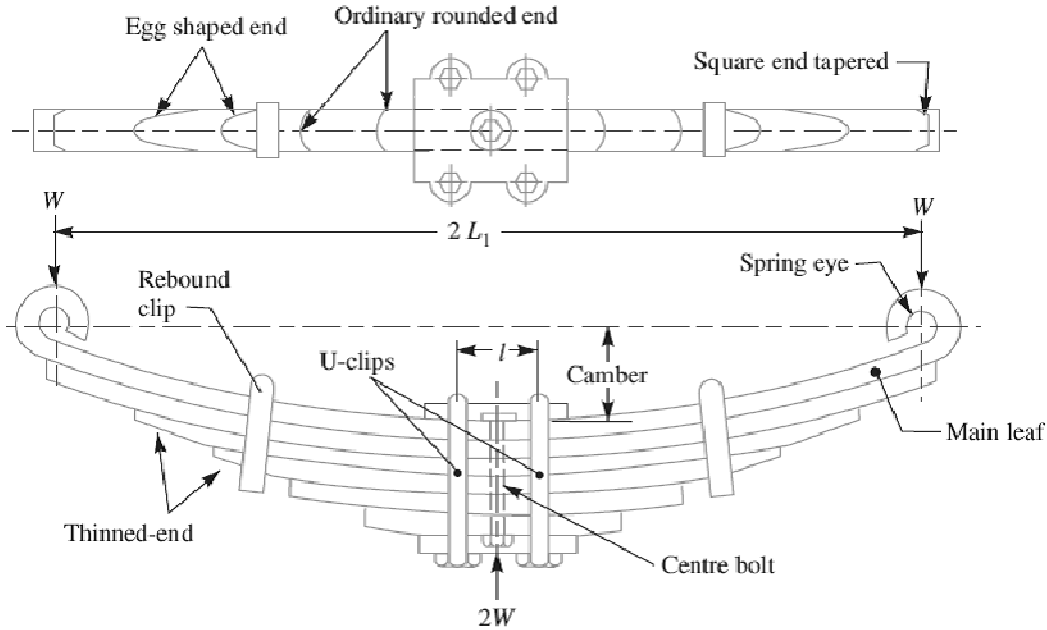

**Equalised Stress in Spring Leaves (Nipping)**

We have already discussed that the stress in the full length leaves is 50% greater than the stress in the graduated leaves. In order to utilise the material to the best advantage, all the leaves should be equally stressed.

This condition may be obtained in the following two ways:

1. By making the full length leaves of smaller thickness than the graduated leaves. In this way, the full length leaves will induce smaller bending stress due to small distance from the neutral axis to the edge of the leaf.
2. By giving a greater radius of curvature to the full length leaves than graduated leaves, as shown in Fig. before the leaves are assembled to form a spring. By doing so, a gap or clearance will be left between the leaves. This initial gap, as shown by C in Fig, is called *nip*.

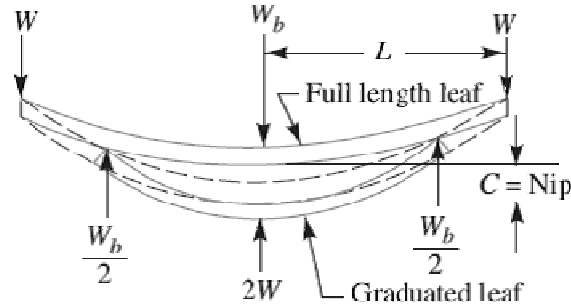

Consider that under maximum load conditions, the stress in all the leaves is equal. Then at maximum load, the total deflection of the graduated leaves will exceed the deflection of the full length leaves by an amount equal to the initial gap  $C$ . In other words,

$$\delta_G = \delta_F + C$$

$$C = \delta_G - \delta_F = \frac{6 W_G \cdot L^3}{n_G E b t^3} - \frac{4 W_F \cdot L^3}{n_F E b t^3} \quad \dots(i)$$

Since the stresses are equal, therefore

$$\sigma_G = \sigma_F$$

$$\frac{6 W_G \cdot L}{n_G b t^2} = \frac{6 W_F \cdot L}{n_F b t^2} \quad \text{or} \quad \frac{W_G}{n_G} = \frac{W_F}{n_F}$$

$$\therefore W_G = \frac{n_G}{n_F} \times W_F = \frac{n_G}{n} \times W$$

$$W_F = \frac{n_F}{n_G} \times W_G = \frac{n_F}{n} \times W$$

Substituting the values of  $W_G$  and  $W_F$  in equation (i), we have

$$C = \frac{6 W \cdot L^3}{n \cdot E \cdot b \cdot t^3} - \frac{4 W \cdot L^3}{n \cdot E \cdot b \cdot t^3} = \frac{2 W \cdot L^3}{n \cdot E \cdot b \cdot t^3} \quad \dots(ii)$$

The load on the clip bolts ( $W_b$ ) required to close the gap is determined by the fact that the gap is equal to the initial deflections of full length and graduated leaves.

$$\therefore C = \delta_F + \delta_G$$

$$\frac{2 W \cdot L^3}{n \cdot E \cdot b \cdot t^3} = \frac{4 L^3}{n_F \cdot E \cdot b \cdot t^3} \times \frac{W_b}{2} + \frac{6 L^3}{n_G \cdot E \cdot b \cdot t^3} \times \frac{W_b}{2}$$

Or

$$\frac{W}{n} = \frac{W_b}{n_F} + \frac{3 W_b}{2 n_G} = \frac{2 n_G \cdot W_b + 3 n_F \cdot W_b}{2 n_F \cdot n_G} = \frac{W_b (2 n_G + 3 n_F)}{2 n_F \cdot n_G}$$

$$W_b = \frac{2 n_F \cdot n_G \cdot W}{n (2 n_G + 3 n_F)} \quad \dots(iii)$$

The final stress in spring leaves will be the stress in the full length leaves due to the applied load *minus* the initial stress.

Final stress,

$$\begin{aligned} \sigma &= \frac{6 W_F \cdot L}{n_F \cdot b \cdot t^2} - \frac{6 L}{n_F \cdot b \cdot t^2} \times \frac{W_b}{2} = \frac{6 L}{n_F \cdot b \cdot t^2} \left( W_F - \frac{W_b}{2} \right) \\ &= \frac{6 L}{n_F \cdot b \cdot t^2} \left[ \frac{3 n_F}{2 n_G + 3 n_F} \times W - \frac{n_F \cdot n_G \cdot W}{n (2 n_G + 3 n_F)} \right] \\ &= \frac{6 W \cdot L}{b \cdot t^2} \left[ \frac{3}{2 n_G + 3 n_F} - \frac{n_G}{n (2 n_G + 3 n_F)} \right] \\ &= \frac{6 W \cdot L}{b \cdot t^2} \left[ \frac{3 n - n_G}{n (2 n_G + 3 n_F)} \right] \\ &= \frac{6 W \cdot L}{b \cdot t^2} \left[ \frac{3 (n_F + n_G) - n_G}{n (2 n_G + 3 n_F)} \right] = \frac{6 W \cdot L}{n \cdot b \cdot t^2} \quad \dots(iv) \end{aligned}$$

### Length of Leaf Spring Leaves

The length of the leaf spring leaves may be obtained as discussed below :

Let  $2L_1$  = Length of span or overall length of the spring,

$l$  = Width of band or distance between centres of  $U$ -bolts. It is the in effective length of the spring,

$n_F$  = Number of full length leaves,

$n_G$  = Number of graduated leaves, and

$n$  = Total number of leaves =  $n_F + n_G$ .

We have already discussed that the effective length of the spring,

$2L = 2L_1 - l$  ... (When band is used)

### References:

1. Machine Design - V.Bandari .
2. Machine Design – R.S. Khurmi

3. Design Data hand Book - S MD Jalaludin.



Problem: Design a leaf spring for the following specifications:

Total load = 140 kN ; Number of springs supporting the load = 4 ; Maximum number of leaves = 10; Span of the spring = 1000 mm ; Permissible deflection = 80 mm.

Take Young's modulus,  $E = 200 \text{ kN/mm}^2$  and allowable stress in spring material as 600 MPa.

**Solution.** Given : Total load = 140 kN ; No. of springs = 4;  $n = 10$  ;  $2L = 1000 \text{ mm}$  or  $L = 500 \text{ mm}$  ;  $\delta = 80 \text{ mm}$  ;  $E = 200 \text{ kN/mm}^2 = 200 \times 10^3 \text{ N/mm}^2$  ;  $\sigma = 600 \text{ MPa} = 600 \text{ N/mm}^2$

We know that load on each spring,

$$2W = \frac{\text{Total load}}{\text{No. of springs}} = \frac{140}{4} = 35 \text{ kN}$$

$$\therefore W = 35 / 2 = 17.5 \text{ kN} = 17\,500 \text{ N}$$

Let  $t$  = Thickness of the leaves, and  
 $b$  = Width of the leaves.

We know that bending stress ( $\sigma$ ),

$$600 = \frac{6 W.L}{n.b.t^2} = \frac{6 \times 17\,500 \times 500}{n.b.t^2} = \frac{52.5 \times 10^6}{n.b.t^2}$$

$$\therefore n.b.t^2 = 52.5 \times 10^6 / 600 = 87.5 \times 10^3 \quad \dots(i)$$

and deflection of the spring ( $\delta$ ),

$$80 = \frac{6 W.L^3}{n.E.b.t^3} = \frac{6 \times 17\,500 (500)^3}{n \times 200 \times 10^3 \times b \times t^3} = \frac{65.6 \times 10^6}{n.b.t^3}$$

$$\therefore n.b.t^3 = 65.6 \times 10^6 / 80 = 0.82 \times 10^6 \quad \dots(ii)$$

Dividing equation (ii) by equation (i), we have

$$\frac{n.b.t^3}{n.b.t^2} = \frac{0.82 \times 10^6}{87.5 \times 10^3} \quad \text{or} \quad t = 9.37 \text{ say } 10 \text{ mm Ans.}$$

Now from equation (i), we have

$$b = \frac{87.5 \times 10^3}{n.t^2} = \frac{87.5 \times 10^3}{10 (10)^2} = 87.5 \text{ mm}$$

and from equation (ii), we have

$$b = \frac{0.82 \times 10^6}{n.t^3} = \frac{0.82 \times 10^6}{10 (10)^3} = 82 \text{ mm}$$

Taking larger of the two values, we have width of leaves,

$$b = 87.5 \text{ say } 90 \text{ mm Ans.}$$

Problem:

A truck spring has 12 number of leaves, two of which are full length leaves.

The spring supports are 1.05 m apart and the central band is 85 mm wide. The central load is to be 5.4 kN with a permissible stress of 280 MPa. Determine the thickness and width of the steel spring leaves. The ratio of the total depth to the width of the spring is 3. Also determine the deflection of the spring.

**Solution.** Given :  $n = 12$  ;  $n_F = 2$  ;  $2L_1 = 1.05 \text{ m} = 1050 \text{ mm}$  ;  $l = 85 \text{ mm}$  ;  $2W = 5.4 \text{ kN} = 5400 \text{ N}$  or  $W = 2700 \text{ N}$  ;  $\sigma_F 280 \text{ MPa} = 280 \text{ N/mm}^2$

*Thickness and width of the spring leaves*

Let  $t =$  Thickness of the leaves, and  
 $b =$  Width of the leaves.

Since it is given that the ratio of the total depth of the spring ( $n \times t$ ) and width of the spring ( $b$ ) is 3, therefore

$$\frac{n \times t}{b} = 3 \text{ or } b = n \times t / 3 = 12 \times t / 3 = 4 t$$

We know that the effective length of the spring,

$$2L = 2L_1 - l = 1050 - 85 = 965 \text{ mm}$$

$$\therefore L = 965 / 2 = 482.5 \text{ mm}$$

and number of graduated leaves,

$$n_G = n - n_F = 12 - 2 = 10$$

Assuming that the leaves are not initially stressed, therefore maximum stress or bending stress for full length leaves ( $\sigma_F$ ),

$$280 = \frac{18 W.L}{b.t^2 (2n_G + 3n_F)} = \frac{18 \times 2700 \times 482.5}{4 t \times t^2 (2 \times 10 + 3 \times 2)} = \frac{225\,476}{t^3}$$

$$\therefore t^3 = 225\,476 / 280 = 805.3 \text{ or } t = 9.3 \text{ say } 10 \text{ mm Ans.}$$

and  $b = 4 t = 4 \times 10 = 40 \text{ mm Ans.}$

*Deflection of the spring*

We know that deflection of the spring,

$$\begin{aligned} \delta &= \frac{12 W.L^3}{E.b.t^3 (2n_G + 3n_F)} \\ &= \frac{12 \times 2700 \times (482.5)^3}{210 \times 10^3 \times 40 \times 10^3 (2 \times 10 + 3 \times 2)} \text{ mm} \end{aligned}$$

$$= 16.7 \text{ mm Ans.} \quad \dots \text{ (Taking } E = 210 \times 10^3 \text{ N/mm}^2\text{)}$$

**References:**

1. Machine Design - V.Bandari .

2. Machine Design – R.S. Khurmi
3. Design Data hand Book - S MD Jalaludin.

