

MODULE1

DEVELOPMENT OF TELECOMMUNICATIONS: Network structure, Network services, terminology, Regulation, Standards. Introduction to telecommunications transmission, Power levels, Four wire circuits, Digital transmission, FDM, TDM, PDH and SDH [Text-1] - **8 Hours.**

CHAPTER 1: DEVELOPMENT OF TELECOMMUNICATIONS

1.1 Introduction

1.1.1 Development of telecommunication

All human activities depend on using information. Information comes in variety of forms including human speech, written, typed and printed documents and computer data. They are so many technologies to processes, to store in memory and to transport the information.

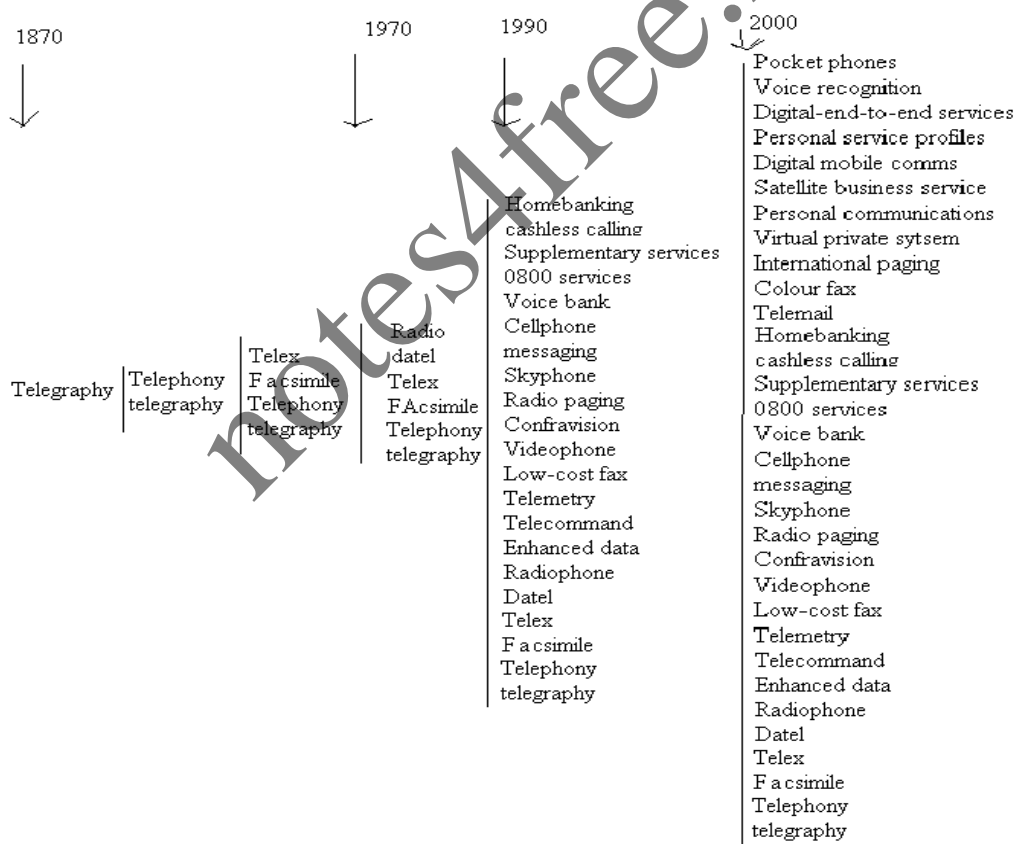

Fig.1.1 Growth of telecommunication s services

Telecommunication is the most important means of transporting information. It is done by converting information into electrical signals and transmitting these over a distance.

Electrical communication began with the invention of the telegraph by Wheatstone and Morse in 1837. Telegraphy system consisted mainly of separate point-to-point lines, sending information in one direction at a time. **Alexander Graham Bell** invented telephone in 1876 and first telephone exchange at **New Haven**. The telephone network made it necessary for lines to be connected together to permit two way conversation.

The figure 1.1 shows the growth of telecommunication services. The many participants of telecommunication business are, namely the users, the public telecommunication operators (PTO), provider of services that involve telecommunications, the manufactures of equipment and components financials investors and governments.

1.2 Network structure

There are mainly five types of network structures or topologies or configurations. They are mesh, bus, ring, star and tree.

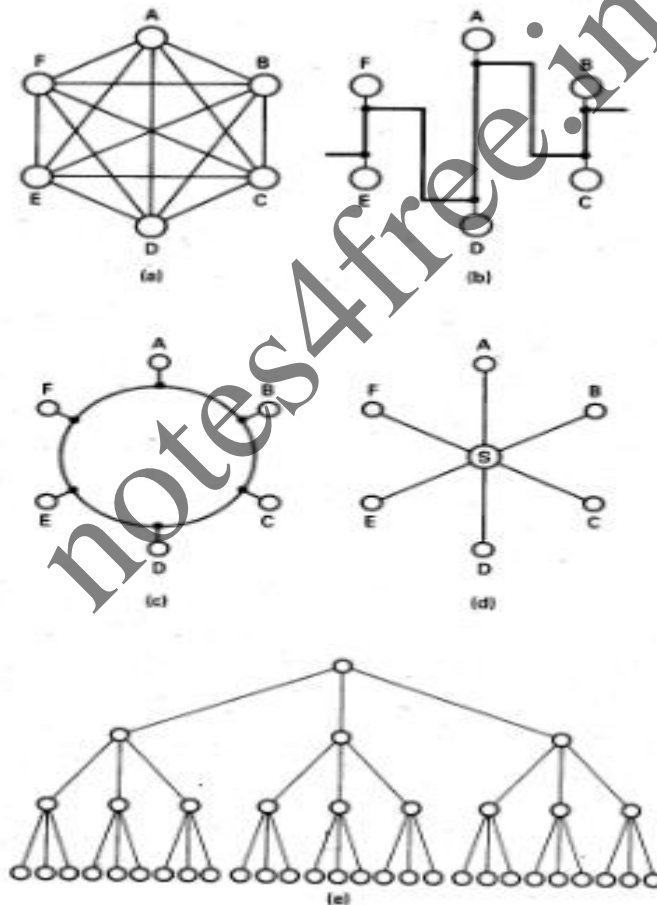

Fig. 1.2 Network configurations (a) mesh (b) Bus (C) ring (d) star and (e) tree

Mesh network

Mesh network is one, it consisting of lines from each station to every other station as shown in figure 1.2a. If communication is required between 'n' users' stations, then mesh network is used. Here each station needs lines to 'n-1' others. Thus, if the lines from A to B can also convey calls from B to A.

The total number of lines required is

$$N = \frac{1}{2} n (n-1)$$

If $n \gg 1$, $N \approx n^2$

The arrangement is practicable if 'n' is very small and the lines are short. Example: a system serving a number of telephone lines in the same office.

Drawback: As 'n' becomes larger, the arrangement becomes more expensive. For example a system having 10000 users' stations would need nearly 50 million lines.

Bus network and ring network

In this type of network each station is connect to a single line, forming a bus or ring as shown in figure 1.2b and 1.2c. These are not useful for telephony application, since only one conversation at a time can takes place. However bus and ring network can be used for data communication by transmitting data over the common circuit at a much higher rate than it is generated by the individual terminals.

Application: These configuration are used in local area networks (LANs) for data transmission over short distances

Star network

In star network line from each user station is connected to the central switching centre (e.g. a telephone exchange) which connects the lines together as required. This configuration is shown in figure 1.2d. These are used in telephone applications, where two-way communication is required, on demand, between any pair of stations. The number of lines required is $N=n$.

When the number of station increases, then area covered by the star network grows and line cost increases. Then we divide the area served by single exchange into area with several exchanges as shown in figure 1.3a and 1.3b.

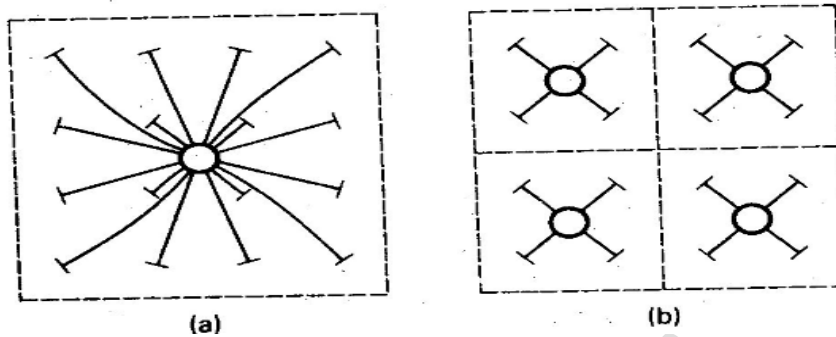

Fig.1.3 subdivision of an exchange area: a) Area with a single exchange b) Area with several exchanges

The average length of customer's line, and thus the total line cost, decreases with the number of exchanges, but cost of providing the exchanges increases. This is shown in figure 1.4, there is optimum number of exchanges, for which total cost is minimum.

Trunk or tandem exchange

A central switching centre, these make connection between the customer's local exchanges.

Multi exchange area

It usually has a direct exchange between some exchanges, but traffic between the other is routed via a tandem exchange (T). It is shown in figure 1.5, is a mixture of star network, joining local exchanges (L) to the tandem exchange, and mesh networks connecting some of the local exchanges together.

Tree network

Tree network is a concatenation of star networks as shown in figure 1.2e. This type of network used in the large national networks to interconnect one or more levels of switching centers. Example of tree network is National public telecommunication network (PSTN) shown in figure 1.6.

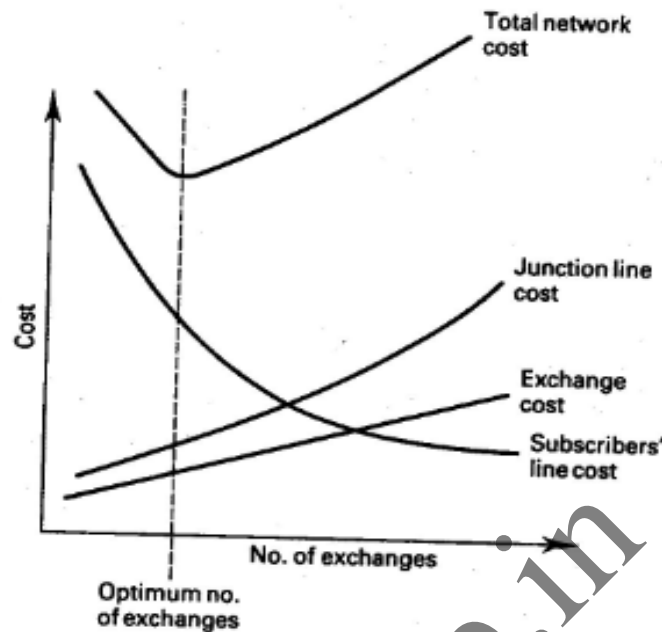

Fig. 1.4 Multi-exchange area: L=Local exchange, T=tandem exchange

In this network there is a direct route between two exchanges at the same level, there is also an alternative route between them via an exchange at the next higher level. When direct circuit is not available may be because of breakdown of connection or when all switching system the lines are busy, we use indirect route to establish a connection. In older such changes can be done by manual operator arrangements. In digital switching systems provides automatic alternative routing (AAR).AAR improve the resilience of the network to withstand break downs and traffic overloads.

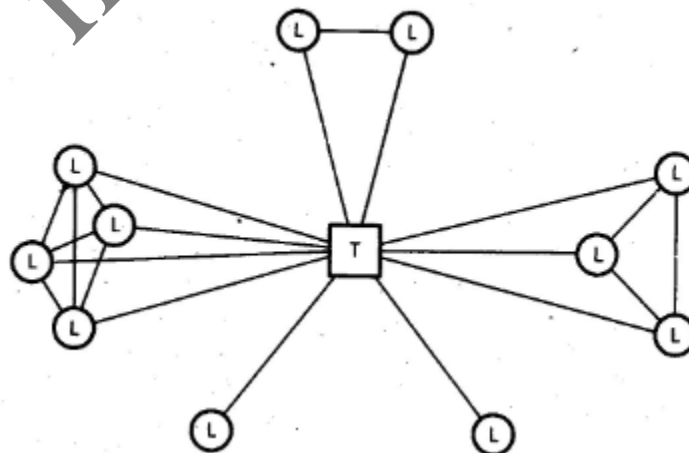

Fig. 1.5 Multi-exchange area: L=Local exchange, T=tandem exchange

A national **Public Telecommunication Network (PSTN)** as shown in figure 1.6 consists of the following hierarchy

1. **Local network:** These connect customer's stations to their local exchanges. It is also called as customer loop, customer access network, or the subscriber distribution network.
2. **Junction network:** This interconnects a group of local exchanges with a tandem or trunk exchange.
3. **Trunk network or toll network:** This provide long distance circuits between local areas throughout the country

The junction network and toll network together called as core network, the inner core consisting of trunk and the outer core consisting of the junction networks. International gateway exchanges: this used to establish connection between international networks (different countries) with national network.

Private branch exchanges (PBX): below the hierarchy of the national public network, some customers have internal lines serving extension telephone. These connected to one another and to lines from the public exchange by a PBX. This may be owned by any company after purchasing from the public telecommunication operators.

A telecommunication network consisting of a large number of transmission links joining different locations, which are known as nodes of the network .there are four different nodes

- **Customer nodes:** a customer terminal forms the node.
- **Switching nodes:** a switching centre forms the other node.
- **Transmission nodes:** here certain circuits are not switched but their transmission paths are joined semi-permanently.

Services nodes: Customers require connection to nodes where there are telephone operators to assist them in making calls and to public emergency services e.g. police, fire, and ambulance services. And also to the value added network services (VANS) such as voice mail boxes, stock market prices and sport results.

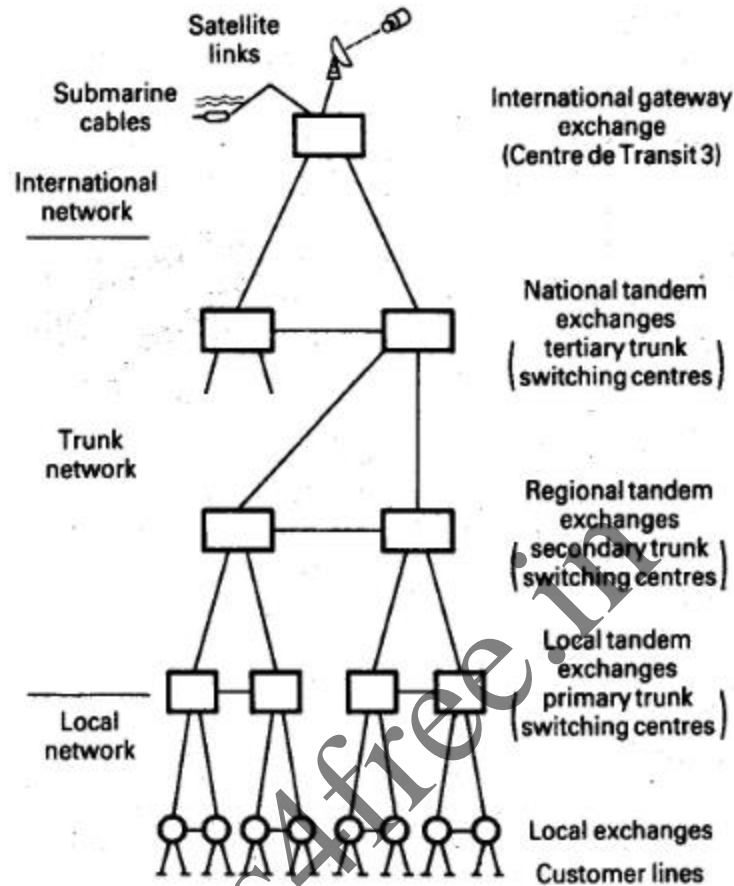

Fig.1.6 National Telecommunication network (PSTN-Public Switched Telecommunication Network)

Signaling:

To make connection to the required destination, and clear it down when no longer required, the customer must send information to the exchange. Such information must be sent between all exchanges on the route. This interchange of information is called is signaling.

A telecommunication network is a system consisting of the following interacting sub systems:

- Transmission system
- Switching systems
- Signaling system

1.3 Network services

The different services required by the customer of the public telecommunication networks are

- The public switched telephone network (PSTN)
- The public switched telegraph network (Telex)

- Private networks for voice and data
- Cellular radio networks providing mobile communication
- Public data networks (PDN), usually employing packet switching
- Special service networks, introduced to meet specialized demands from customers.

Relationship of the service and bearer networks is shown in figure1.7, the different services all use a common transmission bearer network consisting of junction and trunk circuits. Customers are connected to this at their local exchanges via the local access network.

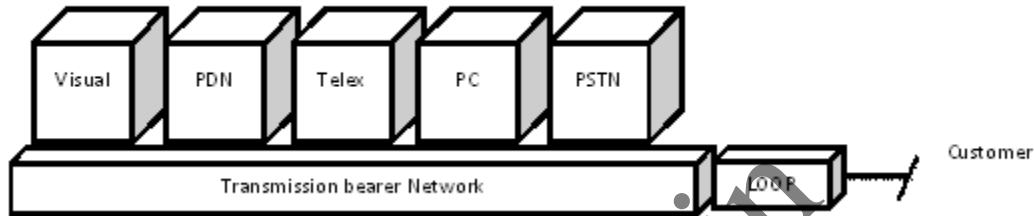

Fig. 1.7 Relationship of services and bearer networks: PC=Private Circuits, PDN=Public Data Network, PSTN=Public Switched Telephone Network.

The services provided over telecommunication networks can be divided into two categories.

1. **Teleservices:** Here provision of the service depends on particular terminal apparatus (e.g. a telephone or teleprinter)
2. **Bearer services:** In which present the customer with transmission capacity that can be used for any desired function (e.g. private circuits)

1.4 Terminology

They are different type’s networks and switching centers are present worldwide. A same network or switching centre named differently in different countries. For example, a switching centre is called an exchange in the UK; in North America switching centre is called central office. The different nomenclature is tabulated in the table 1.1.

Table 1.1. Comparison of Nomenclature

North America	British
Customer’s loop	Local network Access network
Central office	Exchange
End office Class 5 office	Local exchange
Inter office trunk	Junction
Junctor	Trunk
Toll office	Trunk exchange
Toll network	Trunk network

An exchange on which customers lines terminate is a Local exchange in UK but end office in North America. An exchange that switches long distance traffic is called a trunk exchange in UK and toll office in North America.

Circuits between local exchanges or between a local exchange and a tandem exchange and a tandem or trunk exchange are called junctions in the UK, in North America are called trunks. In UK the term trunk is used for a circuit between switches in an exchange, in North America is called a junctor.

1.5 Regulation

In most countries the telecommunication operating companies are privately owned and efforts have been made to state ownership. In **USA**, the customer can only obtain local service from the regional **Bell operating company**, they can choose long distance carrier to use. Tariffs are regulated by **Federal Communication Commission** with the help of **Public Utilities Commissions** of individual states.

In Britain, both British Telecom and Mercury Communications provide local and trunk services. Cable television companies have been licensed to provide telephone services to their customers. Also, three competing cellular mobile radio companies have been established. The **office of the telecommunications** (OFTEL) was setup by government's regulatory body.

Telecommunication network is still a monopoly in most countries or under central government controlled. In **European Union**, the EU commission has issued an **Open Network Provision** (ONP) Directive which requires the telecommunication operators of member states to allow other service providers fair and equal access to leased lines. Similar requirement is introduced in USA, known as Open Network access.

Telecom Regulatory Authority of India (**TRAI**) and Department of Telecommunication (**DOT**) are taking care of the regulation activities along with other service providers.

1.6 Standards

The work of ITU is carried through two main bodies:

1. The ITU telecommunication sectors (ITU-T): formerly called as the **Comite Consultatif Telegraphique et Telephonique** (CCITT).

Its function includes

- the study of technical questions,
- operating methods and
- tariffs for telephony,
- telegraphy and
- data communications.

2. The ITU radio communication sectors (ITU-R): formerly called as the **Comite Consultatif International des Radio communication** (CCIR).

Its function are

- Studying all technical and operating questions relating to radio communication,
- including point-to-point communications,

- mobile services and
- broadcasting.

Associated with **International Frequency Registration Board (IFRB)**, which regulates the assignment of radio frequency to prevent interference between different transmissions.

CHAPTER 2: TELECOMMUNICATION TRANSMISSION

1.7. Introduction to transmission system

Transmission system provides the circuit between the two or more nodes of a telecommunication network and uses paths for transmission of signal called as *channels*.

A Channel passes information through sending equipment at a terminal station, a transmission link, which may contain repeaters at intermediate station and receiving equipment at another terminal end.

There are two types of signals

- Analog signal
- Digital signal
- An analog signal is continuous function of time example speech signals It contain a range of frequencies known as **bandwidth**.
- A digital signal can only have discrete values. Examples of digital signal are binary signal (which s having only two values 1 and 0), telegraph signal and binary coded data from computer.
- The signaling rate is measured in bauds—the baud is number of signaling elements transmitted per second.
- An advantage of digital transmission over analog transmission is its relative immunity to noise and interference
- In **multiplexing**, the signals of different channels are combined to form a composite signal of wider bandwidth and transmitted over the channel.
- In **de-multiplexing** composite signal is separated and retransmitted over different channels. Combination of multiplexer and de-multiplexer is called as muldex or mux.

1.8 Power levels

Power levels are measured in logarithmic unit called as decibel (dB). A logarithmic unit of power is convenient when a number of circuits having gain or loss are connected in a tandem. The unit expressed is decibel (dB), it's a logarithmic unit. The input and output power representation in a telecommunication system is shown in figure 1.8.

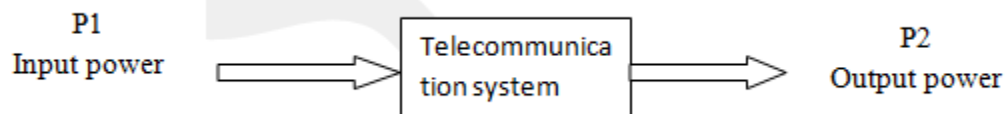

Fig. 1.8 Input and output powers in telecommunication system

If the output power P_2 is greater than input power P_1 , **then Gain** in decibels is

$$G = 10 \log_{10}(P_2/P_1)$$

If the output power P_2 is lesser than input power P_1 , **then Loss** or attenuation in dB is

$$L = 10 \log_{10}(P_1/P_2)$$

The gain and loss in terms of voltage and current it is given by

$$G = 20 \log_{10} \left(\frac{V_2}{V_1} \right) = 20 \log_{10} \left(\frac{I_2}{I_1} \right)$$

The overall gain or loss of a number of the circuits in tandem is simply the algebraic sum of their individual's gains and losses measured in decibels. Since a transmission system contains gains and losses, a signal will have different levels at different points in the system.

- Logarithmic unit of power is convenient when a number of circuits having gain or loss are connected in series.
- If a passive network such as an attenuator pad or filter is inserted in a circuit between its generator and load, the increase in the total loss of the circuit is called as **insertion loss of the network**
- If an active network, such as an amplifier is inserted, the power received by load may increase, this is thus an insertion gain.
- To measure absolute power levels in decibels, we specify a reference level, it is usually in 1mW and symbol used to indicate reference level is dBm. Example of relative levels in an analog transmission system is shown in figure 1.9.

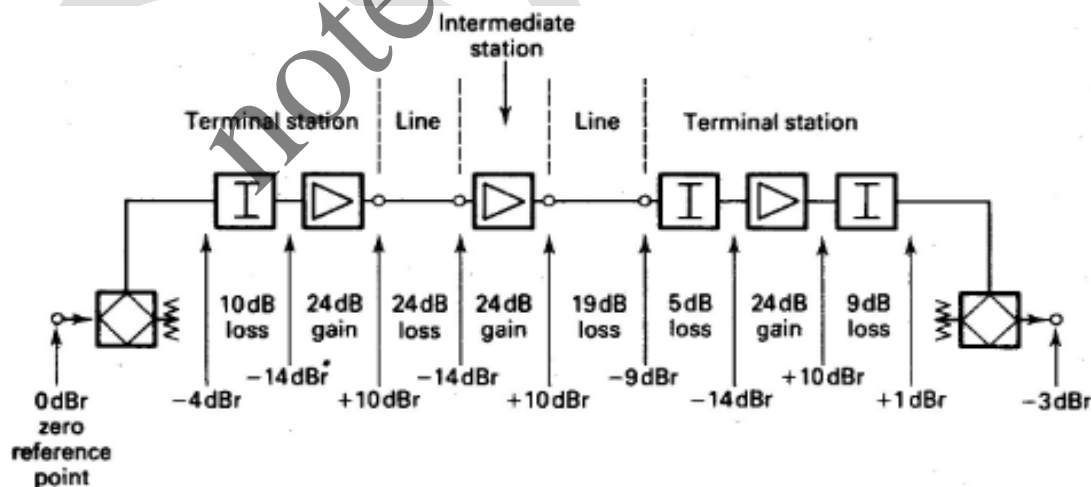

Fig. 1.9 Example of relative levels in an analog transmission system

- Transmission system contains the gains and losses, a signal will have different levels at different ends. These are measured with respect to chosen point called as “**zero reference point**”.
- The **relative level** of a signal at any other point in the system with respect to its levels at the reference point is denoted by dB.

- dBr is equal to the algebraic sum of the gains and losses between that point and the reference point.
- The signal level in terms of the corresponding level at the reference point, denoted as $dBmO$.
 $dBmO = dBm - dBr$.

1.9 Four-wire circuit

The four-wire circuit is shown in figure 1.10. In all circuit amplifiers are used to compensate the attenuation of the transmission path, but most amplifiers are unidirectional. Hence it is necessary to provide a separate channel for the go and return directions of transmissions therefore it is called as four-wire circuit.

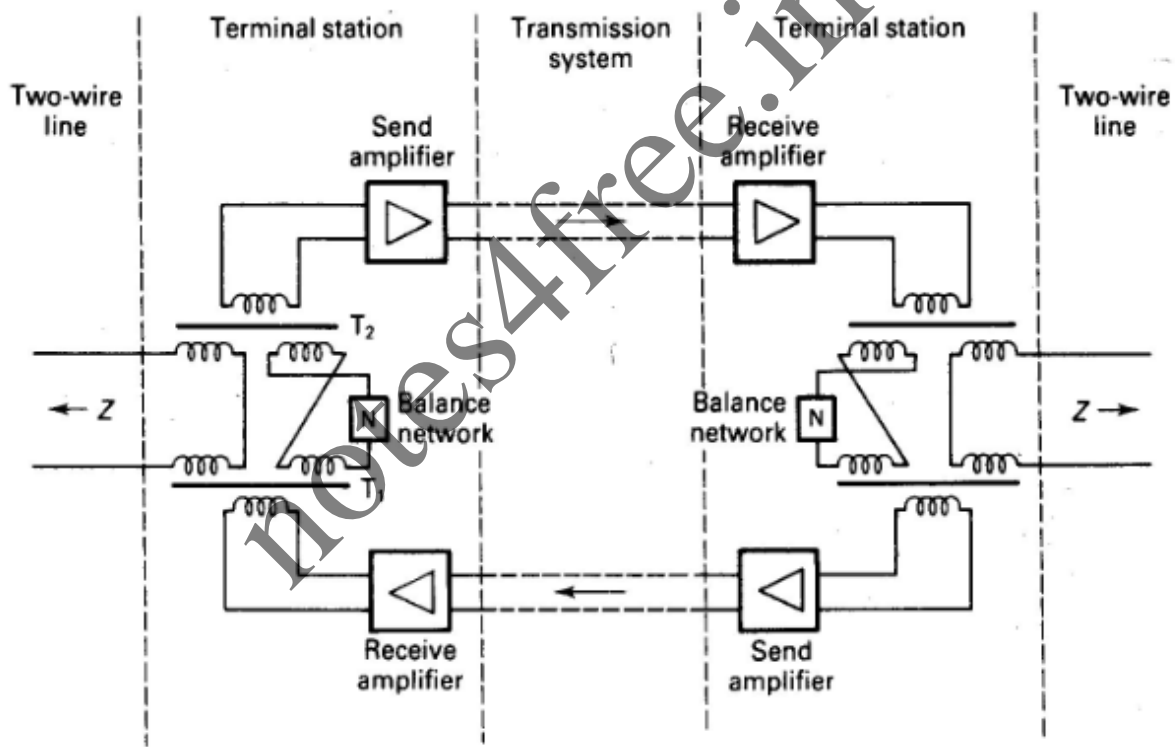

Fig 1.10 Four wire circuit

- The ends of the four-wire circuit are connected to a two wire line leading to a telephone.
- In four-wire circuit, a signal is circulate round the complete loop. This results in continuous oscillations known as singing unless sums of the gains in two directions were less than zero.
- To avoid singing effect, the two wire line end is connected to the Four-wire circuit end with hybrid transformer and a line balance network.

Principle of operation

- The output signal from the receiver amplifier causes equal voltages to be induced in the secondary windings of transformer T1.
- The equal current flows through in the primary winding of the transformer T2 only if the impedances of the two-wire line and the line balance are equal.
- Here no input signal is applied to the input of the send amplifier, because the windings are connected in anti-phase; thus no EMF is induced in the secondary winding of transformer T2
- The output power from the receive amplifier divides equally between the two-wire line and line balance.
- When a signal is applied from the two-wire line, the cross connection between the transformer windings results in zero current in the line balance impedance.
- The power divides equally between the input of the send amplifier and the output of the receive amplifier, where it has no effect.
- In each direction of transmission, the price for avoiding singing is thus 3dB, along with 1dB loss in transformer.
- The impedance of the two wire line varies with frequency. The design of balance network is important to match the impedance over the frequency bands. The simple balanced network may be of 600 Ohm or 700 Ohm.

Echoes:

In a four –wire circuit an imperfect line balance causes part of the signal energy transmitted in one direction to return in the other. The signal reflected to the speaker’s end at the circuit is called talker echo, and that at the listener’s end is called the listener echo. The echo and singing path in the four wire circuit is shown in figure1.11.

The **attenuation** between the two-wire line and the four wire line and vice versa is to be 3dB.

Thus the **total attenuation** from one two wire circuit to the other is $L_2=6-G_4$ dB

Where G_4 ----- net gain of one side of the four –wire circuit

The attenuation through the hybrid transformer from one side of the four –wire circuit to the other is called **Transhybrid loss**. It occurs due to impedance mismatch between the two-wire line and the balance network. It is called as **Balance Return Loss (BRL)**.

This loss is $(6+B)$ where

$$B=20 \log_{10} \frac{N+Z}{N-Z}$$

Z----- Impedance of the two wire line

N-----impedance of the balance network

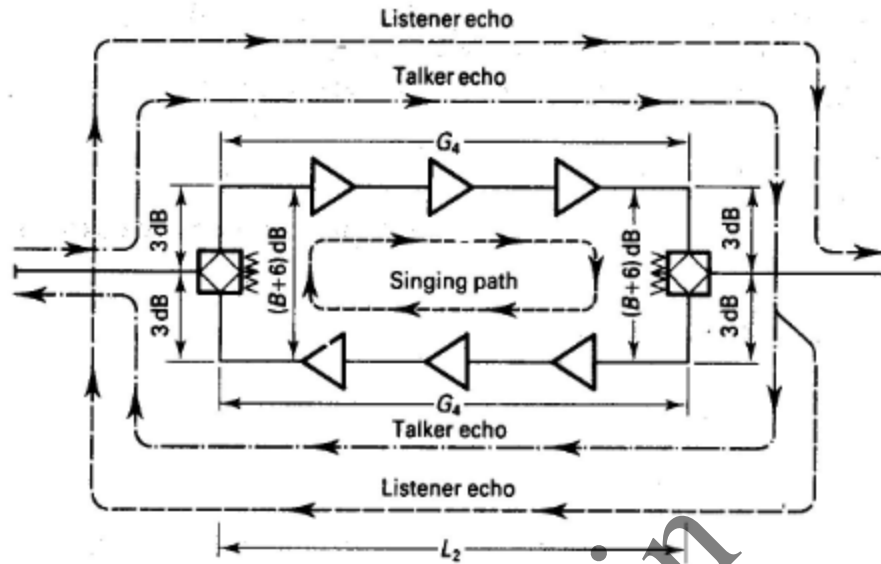

Fig. 1.11 echo and singing path

The attenuation L_t of the echo that reaches the talker's two wire line round the path is shown in figure 1.9 is given by

$$L_t = 3 - G_4 + (B+6) - G_4 + 3 \text{ dB}$$

$$L_t = 2 L_2 + B \text{ dB}$$

This echo is delayed by a time

$$D_t = 2T_4$$

Where T_4 is the delay of the four wire circuit

The attenuation L_l of the echo that reaches the Listener's two wire line is

$$L_l = (B+6) - G_4 + (B+6) - G_4 \text{ dB}$$

$$L_l = 2 L_2 + 2B \text{ dB}$$

To suppress the echo an echo suppressor is used. An echo suppressor consists of a voice operated attenuator, which is present in the one path of the four wire circuit operated by speech signal on the other path.

Stability:

The Balance Return Losses (BRL) of the terminations of a four –wire circuit are sufficiently small and the gains of its amplifier are sufficiently high, the net gain round the loop may exceed zero and singing will occur.

The net loss L_s of the singing path shown in figure 1.11 is explained below

Singing point:

The singing point of a circuit is defined as the maximum gain and that can be obtained without producing is known as singing point of a circuit.

Stability margin:

It is defined as the maximum amount of additional gain, M that can be introduced in each direction of transmission without causing singing,

It is given by

$$L_s = 2L_2 + 2B$$

$$= 2(L_2 + B) \text{ dB}$$

for stability $L_s > 0$

$$L_2 + B > 0$$

$$L_2 = -B$$

$$L_s - 2M = 0$$

$$L_s = 2M$$

$$2(L_2 + B) = 2M$$

$$\text{Singing Point } S = B \qquad M = L_2 + B \text{ dB}$$

The overall Loss can also be given by

$$L_2 = 4.0 + 0.5n \text{ dB}$$

Where L_2 = overall Loss (Two-wire to Two-wire)

N -> number of Four-wire circuits in tandem on the switched connection.

1.10 Digital transmission

Bandwidth

- The minimum bandwidth required to transmit a digital signal at B bauds is given by $W_{\min} = 1/2 B$
- If we pass this signal through low pass filter (LPF), it is possible to detect every pulse without error. i.e. there is no inter symbol interference. It is not possible to obtain the ideal LPF characteristics.
- If the gain of channels changes from unity to zero over a band of frequency, Nyquist showed that zero ISI can be obtained. If gain /frequency response is $f = B/2$
- $F = B$ this occupies twice the minimum bandwidth.

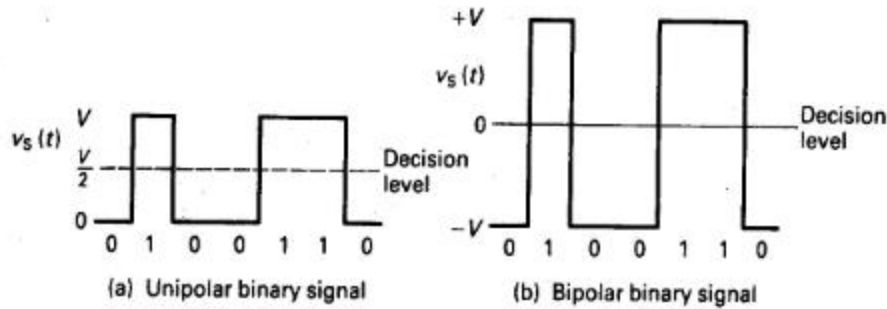

Fig. 1.12 Detection of binary signals

Equalization

- Digital transmission can use gain and phase equalization to obtain negligible ISI.
- Time domain equalizer designed on a basis of impulse response. E.g transversal equalizer.
- If the characteristic of the transmission path change with time, such an equalizer made adjust itself automatically. Such equalizer is called as adaptive equalizer.

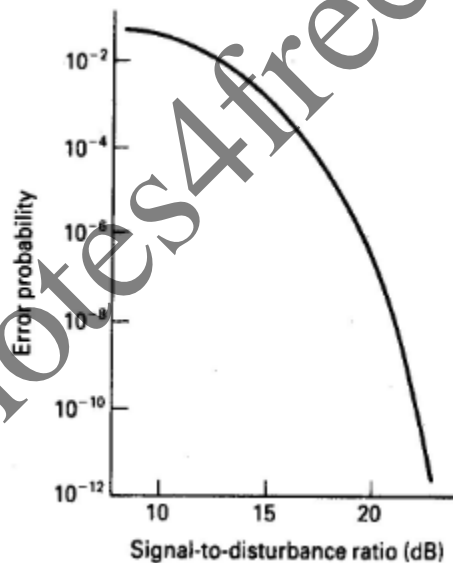

Fig. 1.13 Error rate for transmission of unipolar binary signal

Noise

- The advantage of PCM is that it is possible to obtain good transmission in presence of sever crosstalk and noise.
- In binary transmission, we detect only the presence or absence of each pulse. unipolar signal is shown in figure 1.12a
- For unipolar binary signal the receiver compares the signal voltages V_s with a threshold voltage of $V/2$, if noise voltage V_n is added.

- Error occurs if $V_n > V/2$. If V_n has Gaussian probability density distribution.
- If the bipolar signal is used as shown in figure 1.12b an error occurs if $|V_n| > V$
- The variation of error probability with SNR for a unipolar binary signal distributed by Gaussian noise is shown in figure 1.13c.
- To reduce noise effect in digital transmission regenerative repeaters used instead of analog amplifiers.

Jitter:

- The local oscillator synchronized to digit rate determines the pulses which are retransmitted by a regenerative repeaters and is extracted from received waveform
- Change or variation in the extracted frequency can cause a periodic variation of the times of regenerated pulse known as **jitter**.
- The tolerance of jitter of any subsequent equipment in a link must therefore exceed the amount of jitter produced by preceding equipment.
- Long term variation in the times of the regenerated pulses due to changes in propagation time is known as **wander**.

1.11 FDM

- Here the frequency band is divided into distinct bands.
- In FDM transmission a number of base band channels are sent over a common wide band transmission path.
- Here each channel is modulated with different carrier frequency.
- Such systems are called multi-channel carrier systems.
- A channel translating equipment to multiplex 12 channels is shown in figure 1.14a

Principle of operation:

- Base band signal ($0 < f_m < F_m$) from an audio frequency circuit is applied to a balanced modulator with carrier frequency f_c .
- The output of the modulator is a double sideband suppressed carrier signal $f_c \pm f_m$.
- $f_c \pm f_m$ is input to the band pass filter, this will suppress the upper side band $f_c + f_m$ and transmits the lower side band $f_c - f_m$.
- At the receiving end, the incoming signal is applied to a bank of band pass filters, each of which selects frequency band containing the signal of one channel at a time.
- This signal is applied to a modulator supplied with carrier frequency f_c , and output consists of base band signal and unwanted high frequency components.
- unwanted high frequency components are suppressed by low pass filter and the base band signal is transmitted to the audio frequency circuit.
- The base band and the standard basic group of 12 channels is shown in figures 1.14 b and 1.14c respectively.

- Here carrier spacing is 4KHz, thus 12 channels occupy the band from 60 to 108 KHz and guard band between two channels is 900Hz

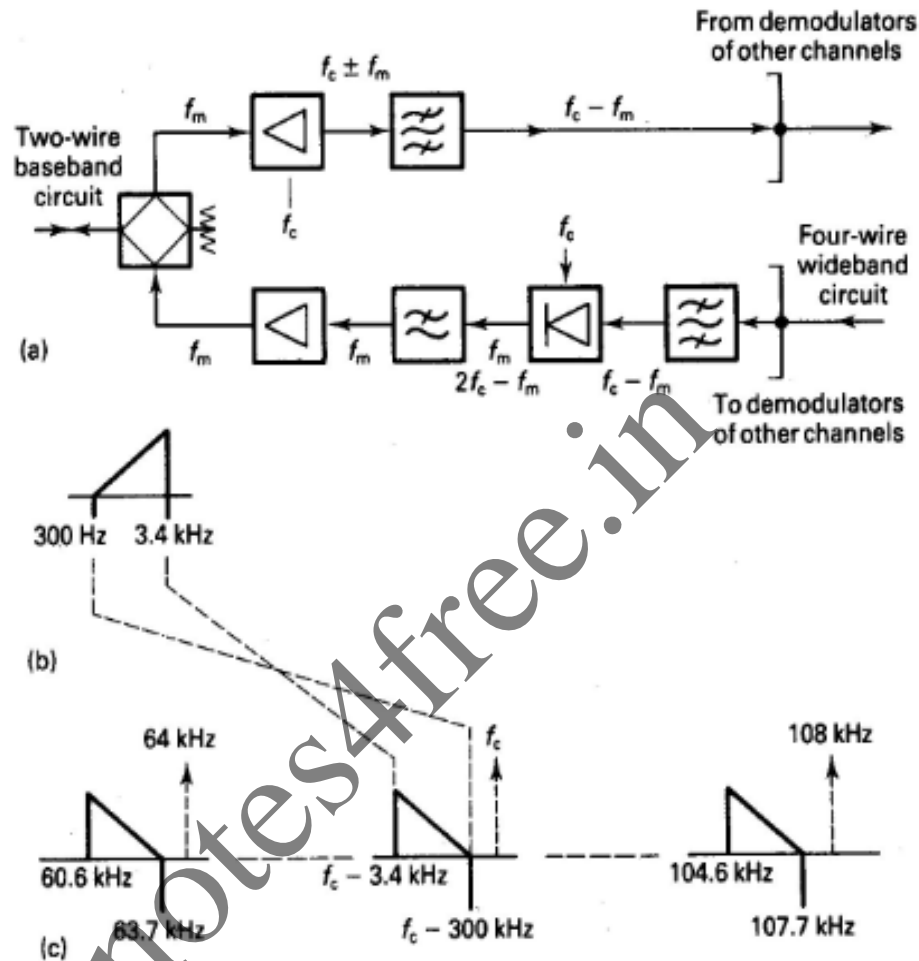

Figure 1.14 Principle of FDM a) Channels Translating equipment b) frequency band of Base band and wideband signal

The hierarchy of FDM channel assemblies is shown in figure 1.15

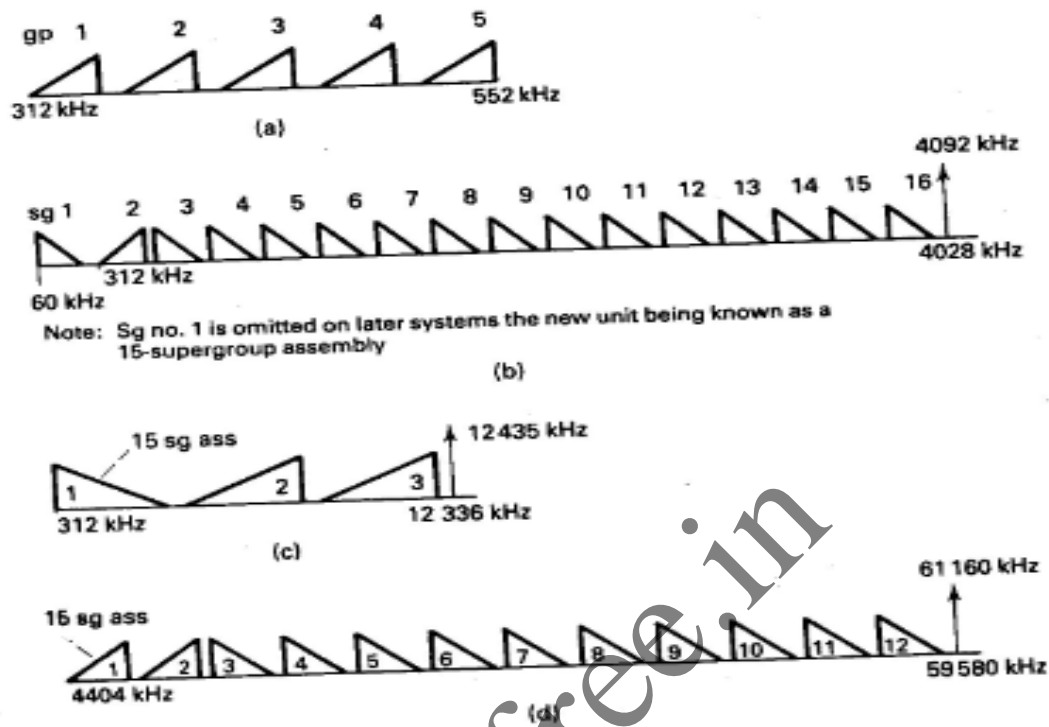

Fig. 1.15. Hierarchy of FDM channel assemblies. (a) basic 5 groups used in 0.5MHz system (b) Assembly of 15+1 super groups (as used in 4MHz system) (c). Assembly of three hyper groups (as used in 12 MHz system) (d). Assembly of 12 hypergroups (as used in 60MHz system)

1.12 TDM

- Time division multiplexing is the extension of the pulse modulation.
- It is the process of dividing the various signals to occupy different time slots.
- A basic time multiplex system is shown in figure 1.16
- In this each base band channel is connected to the transmission path by a sampling gate which is opened for short intervals by means of a train of pulses.
- We are using pulse amplitude modulation at regular interval of time.
- For other channels pulses with same repetition frequency but at different time intervals are applied to the sending gate of the other channels.
- At the receiving side, gates are opened only if pulses coincident with the particular time interval.
- The pulse amplitude modulated signal can be demodulated by a low pass filter with cutoff frequency $f_r/2$ provided that $f_r > 2f_m$ $f_m \rightarrow$ highest base band frequency.
- To accommodate telephone channels with a band 300Hz to 3.4 KHz using LPF, the sampling frequency required is 8Hz.
- We can also use pulse length modulation and pulse position modulation methods but these method not used for line transmission because attenuation and delay distortion causes dispersion of the transmission pulses.

- They spread in time and cause Inter channel crosstalk, to over come this we use pulse code modulation.

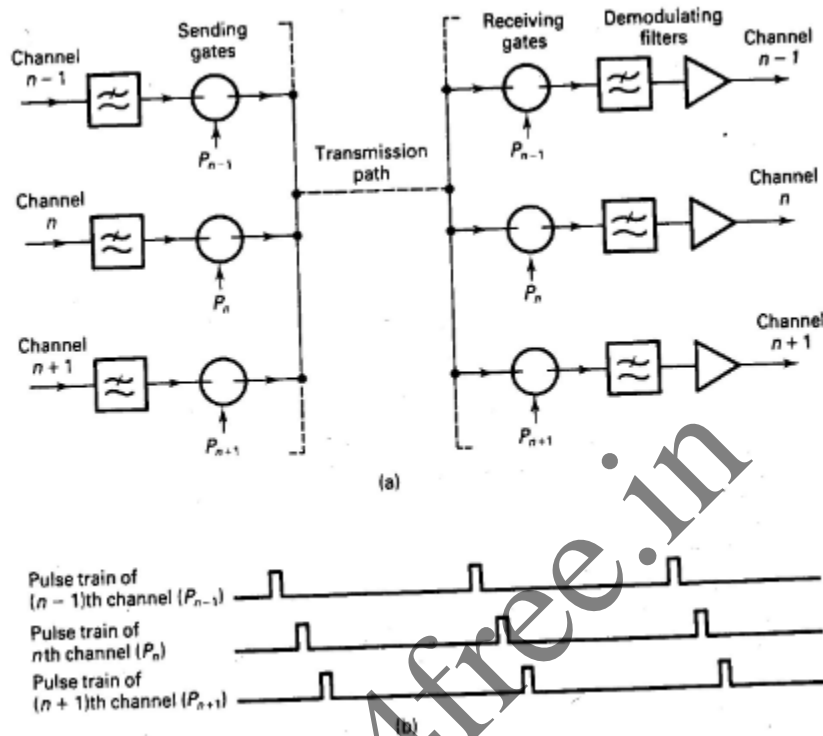

Figure 1.16 principle of Time division multiplex transmission

Pulse code modulation:

- In pulse code modulation, each analog sample is applied to an analog-to-digital converter, which represents its voltage in a binary code. At receiver end digital-to-analog converter is used. The PCM system is shown in figure 1.17
- For all the channels common coder and decoder used in the TDM system for A/D and D/A conversions.
- The group of bits (i.e. binary pulses) representing one sample is called a word or byte. A n 8-bit byte is called as octet.
- For telephony, sampling is carried out at 8 KHz and 8-bit encoding is used.
Rate of transmission = $8 \times 8 = 64$ kilo bauds
- Minimum BW required = $0.5 \times \text{pulse rate} = 0.5 \times 64 \text{ KHz} = 32 \text{ KHz}$.

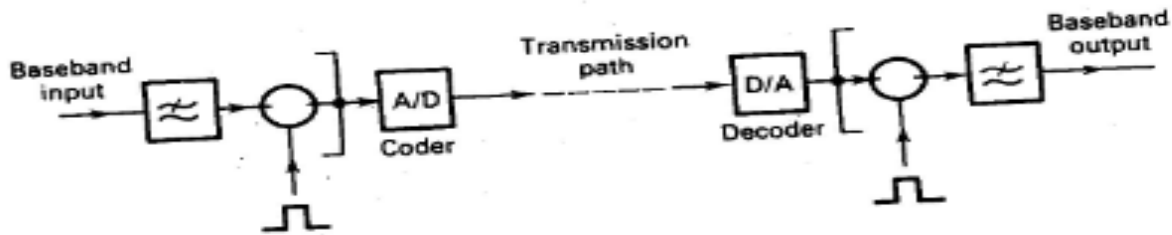

Figure 1.17 PCM System (one way of transmission only)

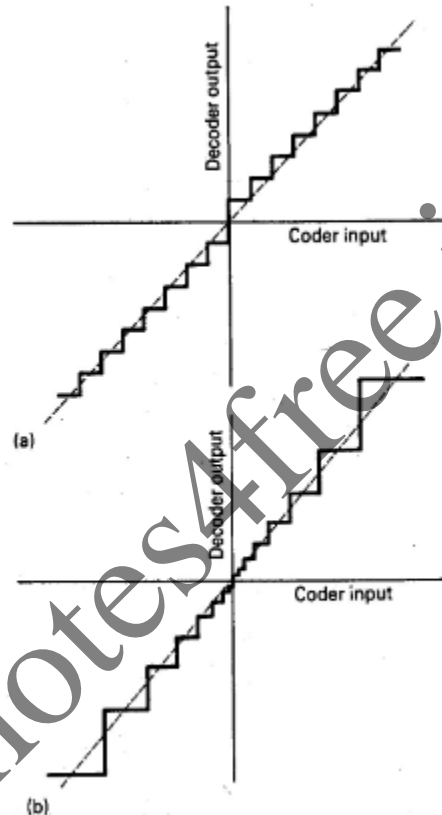

Fig1.18 Quantization characteristics in PCM (a) Uniform Quantization. (b) Non Uniform Quantization

- PCM introduces quantizing distortion. This is the small difference between the output signal and the input signal it is also called as quantizing noise.
- If the coder uses quantizing steps of uniform size is called as uniform quantization.
Small amplitude signal → will have few steps and more distortion.
Large amplitude signal → will have large number of steps and more distortions.
- The effect of quantizing noise can be reduced by using non-uniform quantization (also called as instantaneous companding). two laws are present called as A law and μ law.

The PCM primary multiplex group

Telephone channels are combined by TDM to form an assembly of 24 or 30 channels. This is called as primary multiplex group.

30-channel PCM frame format

- The length of the frame is $125 \mu\text{s}$ corresponding to the sampling intervals.
- The frame is divided into 32 timeslots of each of 8-digits
- Total bit rate = $8\text{K Hz} \times 8 \times 32 = 2.048\text{Mbit/s}$
- Time slots 1 to 15 and 17 to 31 are each allotted to a speech channel. Each slot contains 8 bits D1-D8. D1 is used for polarity and D2- D8 used for speech amplitude.
- Time slot 0 is used for frame alignment
- Time slot 16 is used for signaling. Each bit of channel 16 are shared between the 30 channel by process called as multi-framing.
- As shown in figure 1.19 Frame 0 is used for multi-frame alignment frame 1-15 is divided into 30 channels and each channel uses four bits.
- A single signaling channel operates at 2 Kbit/s
- Four independent signaling channels at 500 bit/s
- Here time slot 16 provides the common signaling channel at 64 Kbit/s.

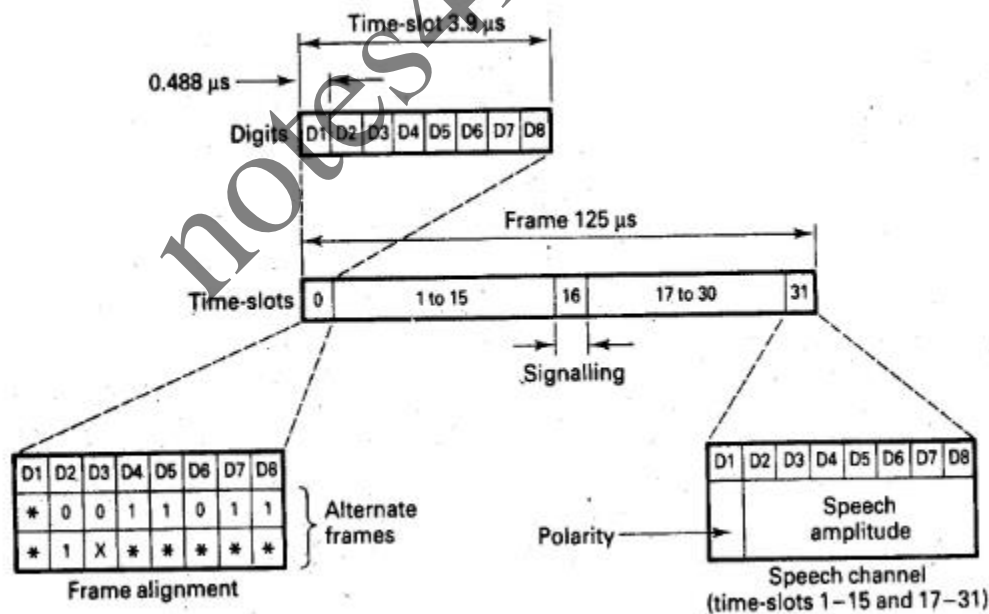

Figure 1.19 30 channel PCM frame format

24 channel PCM frame format

- The 24 channel PCM frame format is shown in figure 1.20
- The length of the frame is $125 \mu\text{s}$ corresponding to the sampling intervals.
- The basic frame contains 193 bits. bit rate = $193 \times 8 \text{ Kbit/sec} = 1.54 \text{ Mbit/sec}$.
- The first bit is used for framing and is called the F-bit. 193rd bit is used for alternate frames for multi-frame alignment. All others from 24 used for speech channels. Each time slot is of 8-bit.
- On odd numbered frames, the F bit takes on the alternating pattern 1,0,1,0 → it is pattern for frame alignment.
- The even numbered frames carry the pattern 0, 0, 1, 1, 1, 0 → it defines 12-frame multi-frame.
- Frames 6 and 12 of the multi-frame bit D8 of each channel time slot is used for signaling instead of speech.
- This process of bit stealing causes a small degradation in quantizing distortion.
- Here the 193rd bit in alternate frame provides common signaling channel at 4 Kbit/s

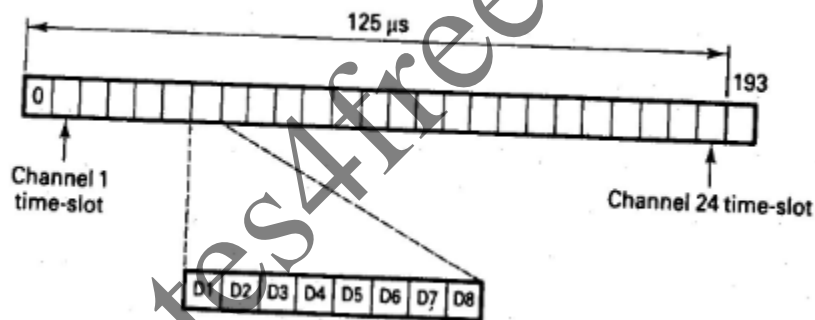

Figure 1.20. 24 channel PCM frame format.

1.13 The plesiochronous digital hierarchy (PDH)

1. The PCM primary multiplex group of 24 or 30 channels is used as a building block for the larger number of channels in the higher order multiplex system.
2. Here several bits streams, known as tributaries are combined by a multiplexer at each level in the hierarchy.
3. Consider a transmission network which is not designed for synchronous and input to the multiplexer are also not exactly synchronous. Although they have the same nominal bit rate, they have originated from different oscillators and can vary within the clock tolerance. They are said to be plesiochronous.
4. If the input to the multiplexer is synchronous i.e., they have the same bit rate and are in phase, they can be interleaved by taking a bit or group of bits from each in turn.
5. There are two main methods of interleaving digital switch
 - Bit interleaving

- Word interleaving

Interleaving of digital signal is shown in figure 1.21

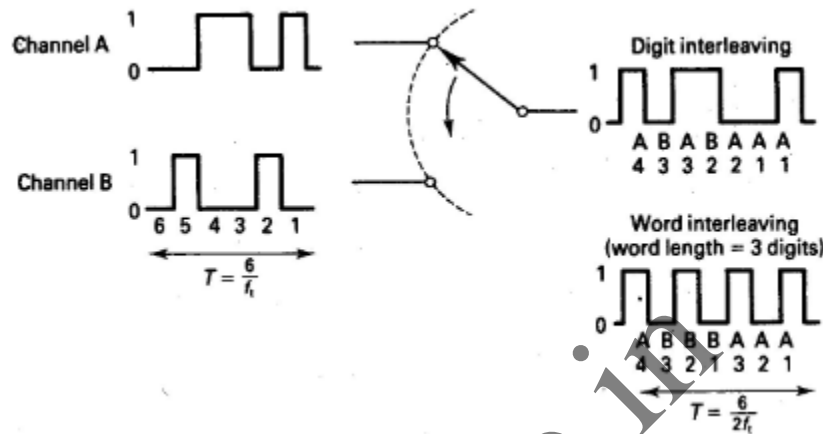

Fig 1.21. Interleaving digital signals (a) Bit interleaving (b) word interleaving

Bit interleaving, one bit is taken from each tributary in turn. If these are N input signals each with a rate of f_t bit/s. Then combined rate will be Nf_t bit/s. In word interleaving, groups of bits are taken from each tributary in turn and this involves the use of storage at each input to hold the bits waiting to be sampled. PDH uses Bit interleaving and SDH uses word interleaving. The European standards are based on the 30-channel primary multiplex hierarchy and North American & Japan standards on the 24 channel primary multiplex hierarchy and these are shown in figure 1.22 and 1.23

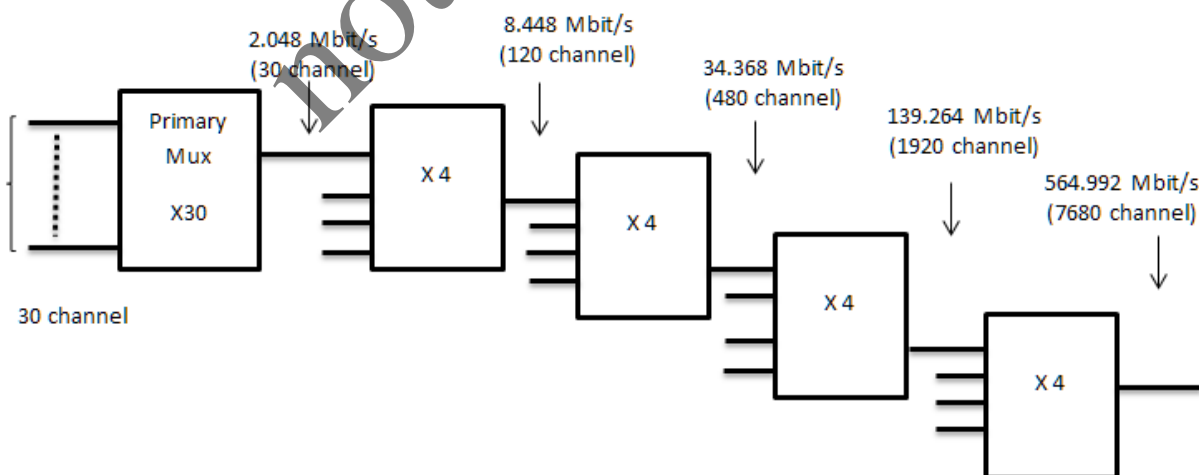

Figure 1.22 European plesichronous digital hierarchy

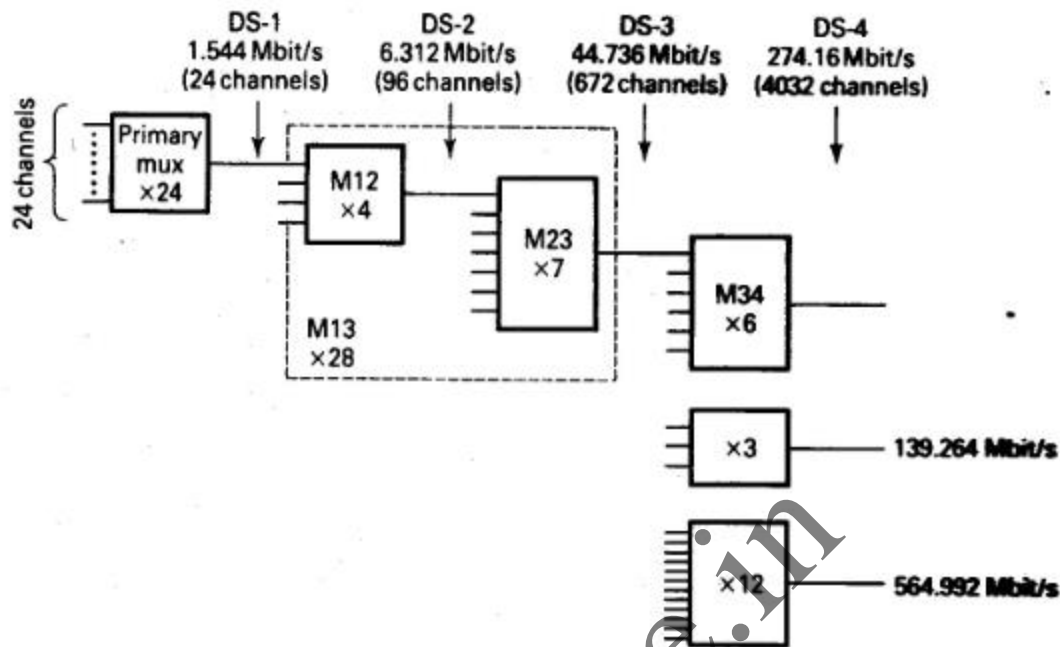

Figure 1.23 North American plesiochronous digital hierarchy

These two systems use bit interleaving. The frame length of primary multiplex is 125 μ sec.

The basic channel sampling rate is 8 KHz.

When N tributaries are combined, the number of digits combined in the higher order frame is greater than N times the number of digits in the tributary frame. Here it is necessary to add extra overhead digits for two reasons.

The first reason is frame alignment. Here a unique code is sent as frame alignment word (FAW), it is recognized by the de multiplexer to maintain its operation in synchronism with incoming digits.

The second reason for adding extra digits to the frame is to perform the process known as justification.

This process is to enable the multiplexer and de multiplexer to maintain correct operation, even though some drift may be present in the input signal.

If the input tributary is slow a dummy digit is added to maintain the correct output digit rate.

If an input tributary speeds up no justification digit is added. These bits are removed at the de multiplexer to get correct sequence.

Total multiplexing mountain is shown in figure 1.24.

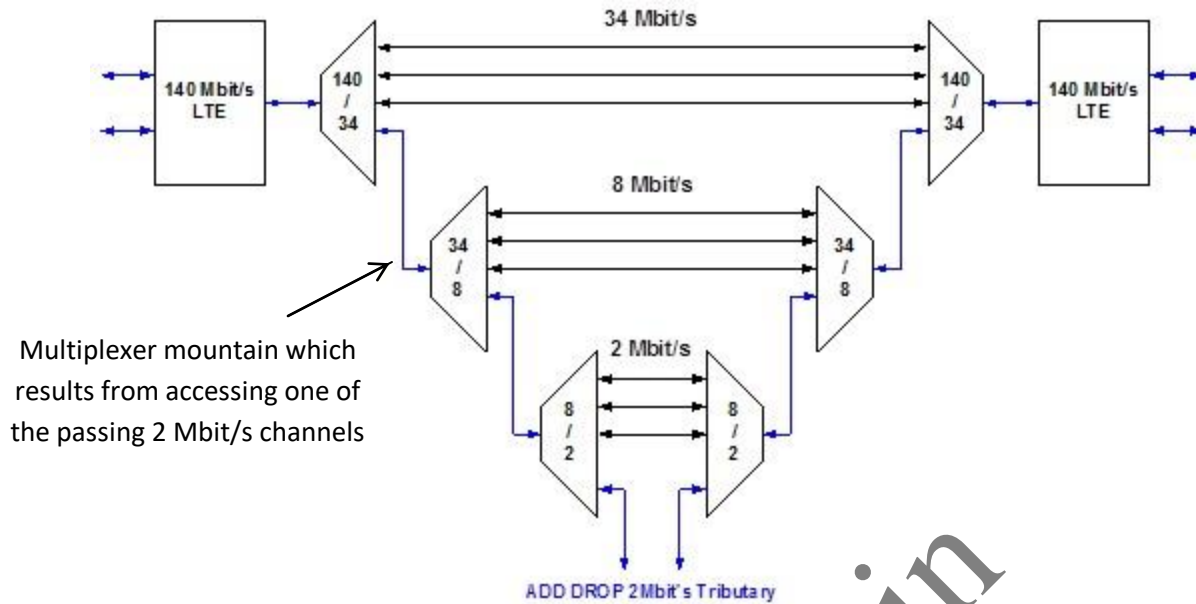

Figure 1.24 The PDH Multiplex Mountain

1.14 The synchronous digital hierarchy (SDH)

- The synchronous digital hierarchy is shown in figure 1.25. It is a new multiplex hierarchy defined by CCITT in 1990.
- In USA it is called synchronous optical network (SONET), optical interfaces uses muldexes.
- The SDH uses a digit rate of 155.52 Mbit/s and multiples of this factor of $4n$ e.g. 622.08Mbit/s and 2488.32Mbit/s
- Any of the existing plesiochronous rates up to 140Mbit/s can be multiplexed into SDH common transport rate of 155.52 Mbit/s

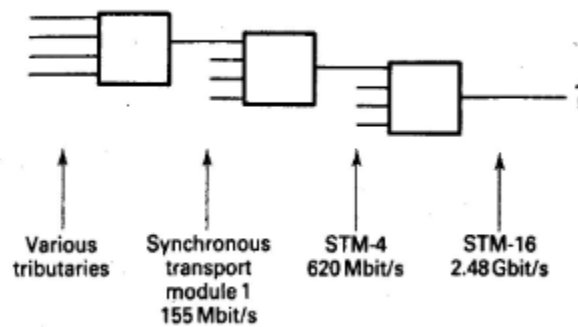

Figure 1.25 the SDH

- The basic SDH signal is called as synchronous transport module at level 1 is shown in figure 1.26a

- This has nine equal segments with overhead bytes at the start of each.
- The remaining byte contains a mixture of traffic and overheads depending on the type of traffic carried. The total length is 2430 bytes, with each overhead using nine bytes.
- Overall bit rate is 155.52 Mbit/s
- This frame is usually 9 rows and 270 columns of 8-bit byte as shown in figure 1.26(b).
- In 270 columns the 9 columns are for section overheads such as frame alignment, error monitoring and data. Remaining 261 columns comprise the payload.

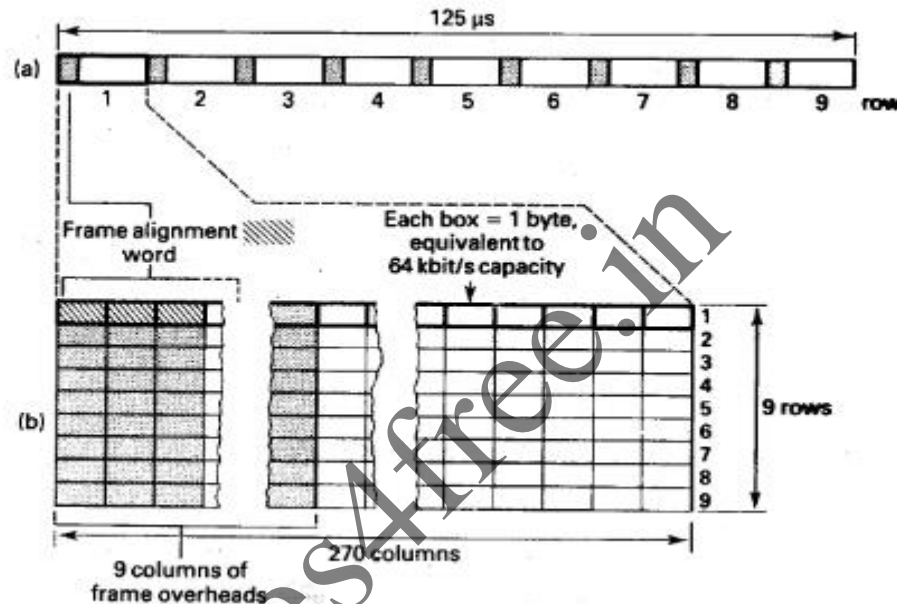

Figure 1.26 SDH frame structure (STM-1)

- Each tributary to the multiplex has its own payload area, known as a **tributary unit (TU)**, in North America, TU called as **virtual tributary (VT)**.
- In multiplexing process, the bytes from a tributary are assembled into a container and a path overhead is added is called **virtual container**.
- in North America, VC called as virtual tributary synchronous payload envelope.

Application of SDH:

The STM-1 frame is used in this way to transport signals from tributaries which use conventional TDM. An alternate method is used to transport to signals in the Asynchronous transfer mode (ATM), messages are transported in cells of 53 bytes, each cell being identified by a combination of digits known as a header.

The SDH provides interface for network management messages in a standard format it can lead to a managed transmission bearer networks.

The ability of SDH to provide add/drop multiplexers can lead to novel network structure. The figure 1.27 shows the four remote sensing units (RSU) connected to a principle local exchange (PLE) in a ring configuration. There are two alternative routes between each pair of exchanges and the synchronous multiplexing (SMX) can be arranged to reroute the traffic in the event of a failure without any higher level network management intervention.

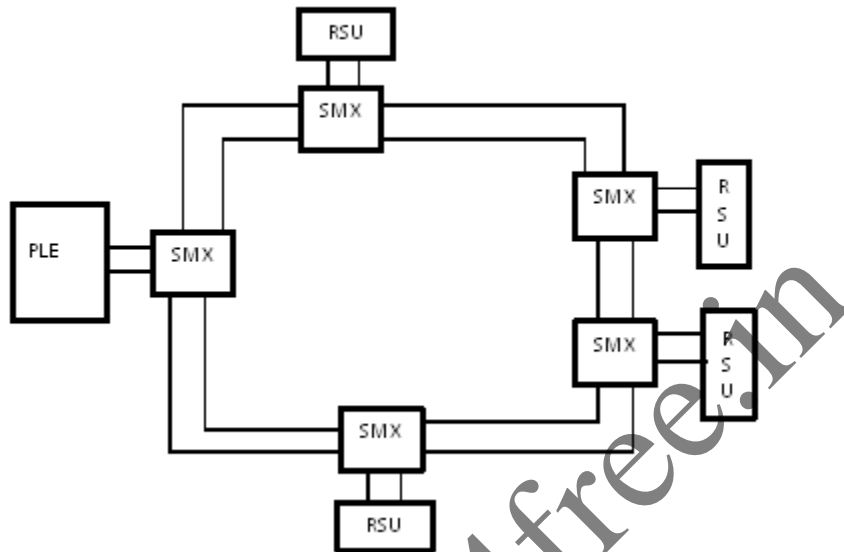

Fig 1.27 Local exchanges connected by synchronous ring. SMX= synchronous mux. PLE=Principal local exchange. RSU=Remote switching unit.

Digital transmission

These links introduces a number of impairments, including bit errors, slip, short breaks , jitter and wander. There are unnoticeable for speech transmission but they can cause unacceptable errors in data transmission.

Acronyms

dB- decibel

dBC-decibel referenced to the carrier level

dBC-decibel referenced to the dipole (antenna)

dB_i- decibel over an isotropic (antenna)

dB_m-decibel referenced to a milliwatt

dB_{mV}- decibel referenced to a millivolt

dBm₀-decibel referenced to zero reference value.

dBm_r- decibel measured at the reference point

References:

TEXT BOOKS:

1. Telecommunication and Switching, Traffic and Networks - J E Flood: Pearson Education, 2002.

MODULE 2

EVOLUTION OF SWITCHING SYSTEMS: Introduction, Message switching, Circuit switching, Functions of switching systems, Distribution systems, Basics of crossbar systems, Electronic switching.
DIGITAL SWITCHING SYSTEMS: Switching system hierarchy, Evolution of digital switching systems, Stored program control switching systems, Building blocks of a digital switching system, Basic call processing. [Text-1 and 2] 8 Hours

CHAPTER1: EVOLUTION OF SWITCHING SYSTEMS

2.1 Introduction

Switching systems and associated signaling systems are very essential to the operation of telecommunication networks. The proper facilities are provided by the switching system through some functions.

The design of switching system has become ever most complicated, In order to provide additional facilities which enable networks to provide more services to customer and to facilities operation and maintenance. In this chapter we are studying about historical approach of the switching system.

2.2 Message switching

Messaging switching is better known as the stored- and forward approach for an entire message.

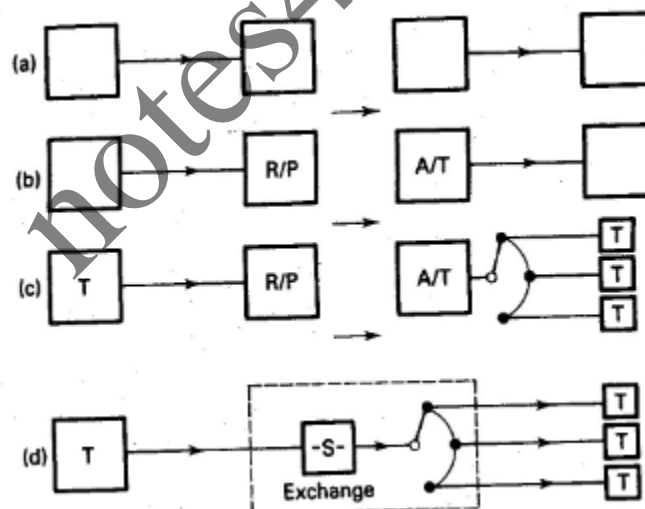

Figure 2.1(a). Manual transfer of a message in message switching Figure 2.1(b) Manual transfer of paper tape (a torn tape relay system) R/P= reperforator A/T= automatic transfer The figure(c) shows the outgoing route was also selected automatically as shown Figure 2.1(c) manual transfer of paper tape with automatic route selection (turn-tape relay system) T= teleprinter The figure (d) shows the paper tape was eliminated by storing the message electronically and analyzing (memory) their address by electronic circuit. Figure 2.1 d) Automatic message switching system S=store

In message switching if there is no direct connections between two customers at two town say source (S) and destination (D), then we can use another town say point (P) to establish the connection in the telegraph circuit.

The operator at town 'S' sends the message at town 'P', where it was written down by the receiving operator. This operator identifies the address of the message as being to town 'D' and then transmitted the message over the circuit of 'p' as shown in figure 2.1

Later improvements made over the above techniques. First step is the message received at 'D' was automatically recorded on punched tape and subsequently turn off the receiver by the operator, who read the address from the tape and message retransmitted automatically from the same tape as shown in figure this was known as a torn tape relay system.

In a message switching center an incoming message is not lost when the required outgoing is busy. It is stored in a queue with any other message for the same route and retransmitted when the required circuit becomes free.

2.3 Circuit switching

Circuit switching allows two-way communication in real time.

In circuit switching system connects the circuit of calling telephone to that of the called telephone on demand and it maintain this connection for the duration of the call.

Here, if the required outgoing circuit from a switch is already engaged on another call, the new call offered to it cannot be connected. The call cannot be stored, it is lost.

Note: Manual switching system, multiple switch board

2.4 Functions of switching systems

The basic functions that all switching system must perform are as follows.

1. **Attending:** the system must be continually monitoring all lines to detect call requests.
2. **Information receiving:** In addition to receiving call and clear signals the system must receive information from the caller as to the called line required. This is called the address lines.
3. **Information processing:** the system must process the information received, in order to determine the actions to be performed and to control these actions.
Since both originating and terminating calls are handled differently for different customers. Class of service information has to be processed to in addition to the address information.
4. **Busy testing:** After processing the received information to determine the required outgoing circuit the system must make a busy test to determine whether it is free or already engaged on another call.
5. **Interconnection:** For a call between two customers, three connections are made in the following sequence.
 - a) A connection to the calling terminal

- b) A connection to the called terminal
- c) A connection between the two terminals (calling terminal and called terminal).

In manual exchange system connections (a) and (b) are made at the two ends of the cord circuit and connections (c) joins them together in the cord circuit.

Many automatic systems also complete connections (c) by joining (a) and (b) at the transmission bridge.

Modern systems release the connections (a) and (b) and establish connection (c) over a separate path through the switching network. This is known as **call-back or crank back**. The calling line is called back and the connection to the called line is cranked back to it.

6. **Alerting:** Having made the connection, the system sends a signal to alert the called customer to the call, e.g. by sending ringing customer's telephone.
7. **Supervision:** After the called terminal has answered the system continues to monitor the connection in order to be able to clear it down when the call has ended. When a charge for the call is made by metering, the supervisory circuit sends pulses over the "P" wire to operate a meter in the line circuit of the calling customer. This process is known as Calling line Identification.
8. **Information sending:** If the called customer's line is located on another exchange the additional function of information sending is required. The originating exchange must signal the required address to the terminating exchange.

Note: strowger step by step exchange, unselector, two motion selectors, group selectors' numerical selectors and final selectors, and Register translator sender.

2.5 Distribution Frames

Many changes occur during the life of a telephone exchange. New customers join and old ones leave. As the number of customers in an exchange increases or if customer move from one exchange area to other exchange area, then in PBX number of lines may increase over 6 months or years from 4000 lines to an ultimate 20,000 lines. Distribution frames in strowger exchange is shown in figure 2.2

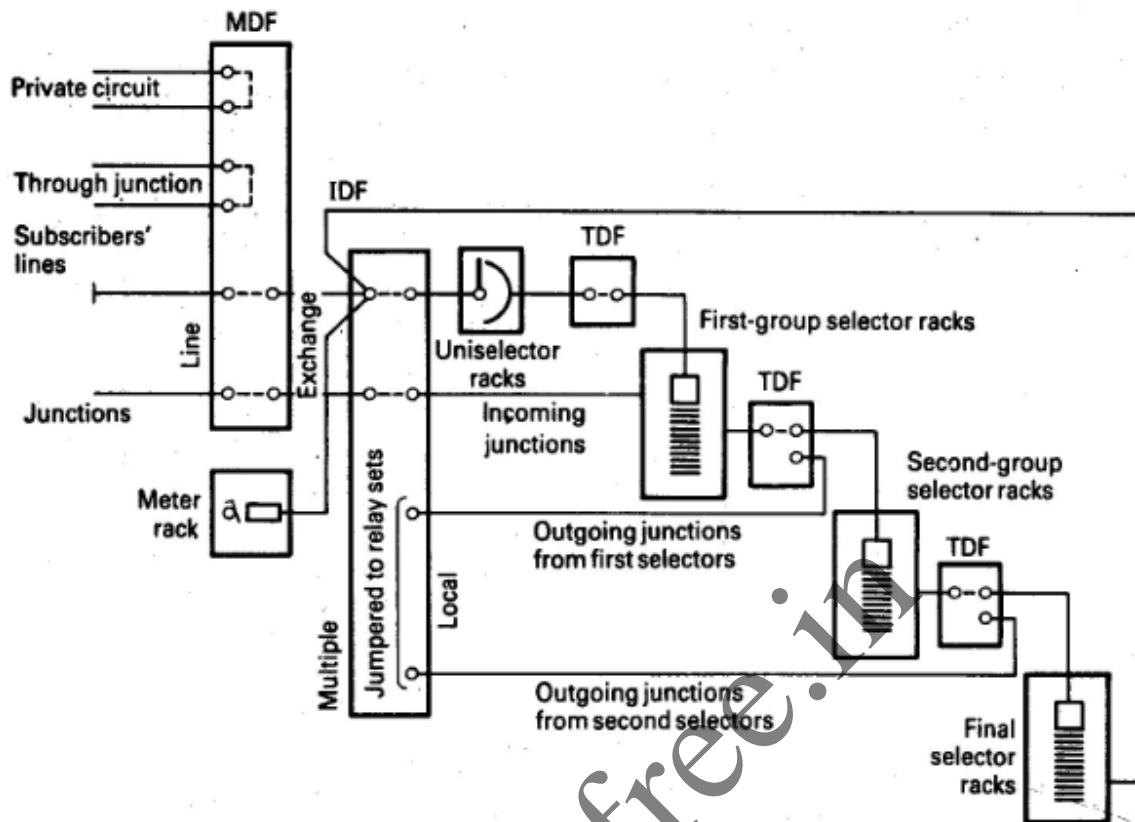

Figure 2.2 distribution frames in strowger exchange

- Growth of traffic may require additional switches in the exchange and more junctions to other exchanges.
- Great flexibility is therefore required in the trunking of an exchange.
- This is obtained by inserting distribution frames into the permanent exchange cabling.
- Frames contain an array of terminal blocks and the terminals are linked in a less permanent fashion by wires called *jumper*s.
- The distribution frames in a typical step-by-step exchange is shown in figure 2.3
- The *main distribution frame (MDF)* is the place where the cables of the customers' distribution network terminate.
- The arrangement of terminals on the line side of the MDF corresponds to the street cabling and so reflects the geography of the area.
- In MDF the exchange terminals are arranged in directory number order.
- To guard the exchange apparatus against any high voltage surges on the external lines, protectors and fuses are mounted on the MDF.
- The MDF also provides a convenient point of access for testing lines and private circuits and through junctions are strapped together at the MDF.
- The *intermediate distribution frame (IDF)* is used to distribute incoming traffic evenly over the group of first selectors.
- On the *multiple side* of the IDF, lines are arranged in the directory number order.
- On the *local side*, the order can be arbitrary to obtain the desired result.

- The terminals on the local side of the IDF are corresponds to equipment number (EN) of the lines and customers uniselectors are connected to this side.
- IDF provides equipment number (EN) to directory number (DN) translation.
- Incoming calls for a customer terminate at *final selectors* on an outlet corresponding to the directory number.
- The final selectors multiples are therefore connected to the multiple side of the IDF.
- A modern system provides DN to EN translation, in order to enable customers' incoming traffic to be redistributed in addition to their outgoing traffic.
- Between the ranks of selectors there are trunk distribution frames (TDF). These are used in the telecommunication system to cater growth in traffic.
- For digital switching system, digital circuits are terminated on a digital distribution frames (DDF).
- In a SPC system, EN-to-DN and DN-to-EN translation may be performed by a central processor reading data from an electronic memory. IDF is not used in SPC system

2.6 Basics of crossbar systems

Strowger switches require regular maintenance. The banks need cleaning, mechanisms needs lubrication and adjustment and wipers and cords wear out.

The disadvantages lead to the development of other forms of switch, namely matrix of telephone relays as shown in figure 2.3 with their contacts multiplied together horizontally and vertically.

Since a switch with N inlets and N outlets, requires N^2 relays for its crosspoint, this was uneconomic for larger exchanges. A more economic solution was provided by the invention of the crossbar switch by G.A Betulander in 1917.

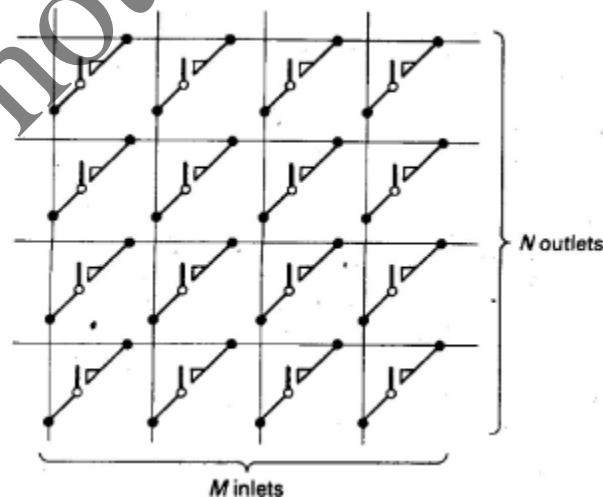

Fig 2.3 Matrix of crosspoints

The crossbar switch retains a set of contacts at each crosspoint, but these are operated through horizontal and vertical bars by magnets at the sides of the switch. Thus, a switch with N inlets and N outlets only needs $2N$ operating magnets and armatures, instead of N^2 .

The magnets which operate the horizontal bars are called select magnets and those operating the vertical bars are called hold magnets or bridge magnets. The mechanism of a crossbar switch is shown in figure 2.4.

Operation of a select magnet tilts one of the horizontal bars up or down. This causes flexible fingers to engage with the contact assemblies of one row of crosspoints and provides the link which was missing from their operating mechanisms.

One of the bridge magnets is then operated and this closes the contacts of the crosspoint at the coordinates corresponding to the horizontal and vertical magnets.

The select magnets are then released, but the finger remains trapped and the cross point contacts remain closed for as long as the bridge magnet is energized.

Current flows in this magnet for as long as the P wire is at earth potential. This persists until a 'clear' signal causes the earth to be removed at the end of a call.

Strowger selectors perform counting and searching. However, the crossbar switch has no intelligence. Something external to the switch must decide which magnets to operate.

This is called a marker. Since it takes less than a second to operate the switch, a marker can control many switches and serve many registers as shown in figure 2.5.

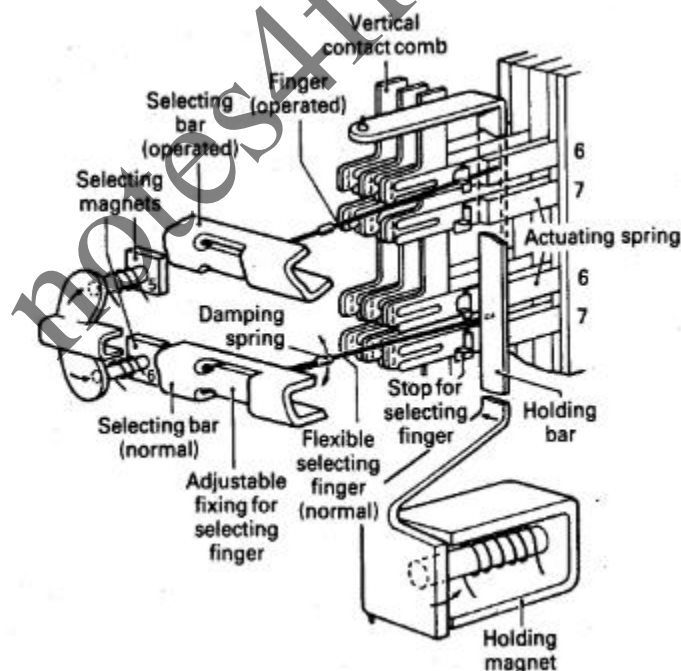

Figure 2.4. The mechanism of a crossbar switch

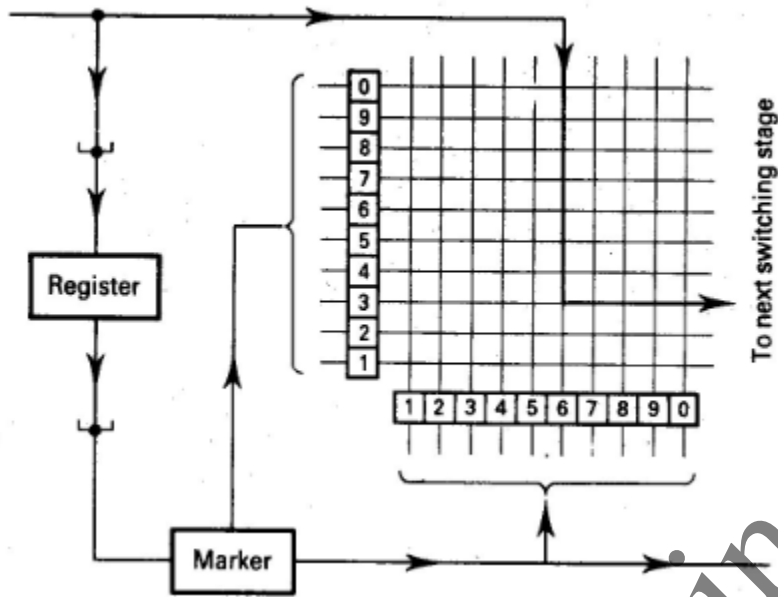

Figure 2.5 marker control of a crossbar switch.

Thus, even a large exchange needs few markers. This is a further stage of common control, which we call centralized control.

A crossbar switch can make many connections as it has vertical bars at a time. It is a group of uniselectors instead of a single two-motion-selector. For example, a switch of size 10 x 10 can make up to ten simultaneous connections between ten incoming trunks and ten outgoing trunks.

Two stage link systems of primary and secondary switches are interconnected to produce larger switches and are called as link frame. The figure 2.6 shows twenty switches of size 10 x 10 used to interconnect 100 incoming trunks to 100 outgoing trunks

In figure 2.6 the number of an outlet on a primary switch corresponds to the number of the secondary switch to which its links goes and the number of an inlet on a secondary switch corresponds to the number of the primary switch from which its link comes.

Example link 23 connects outlet 3 of the primary switch 2 to inlet 2 of the secondary switch 3.

In the above figure there is only one link from a primary switch to a secondary switch. When a connection is required, this path may be busy because it is already in use for a connection from another incoming trunk on that primary switch to another outgoing trunk on that secondary switch. The call attempt fails, although the outgoing trunk is free. This situation is known as **blocking**.

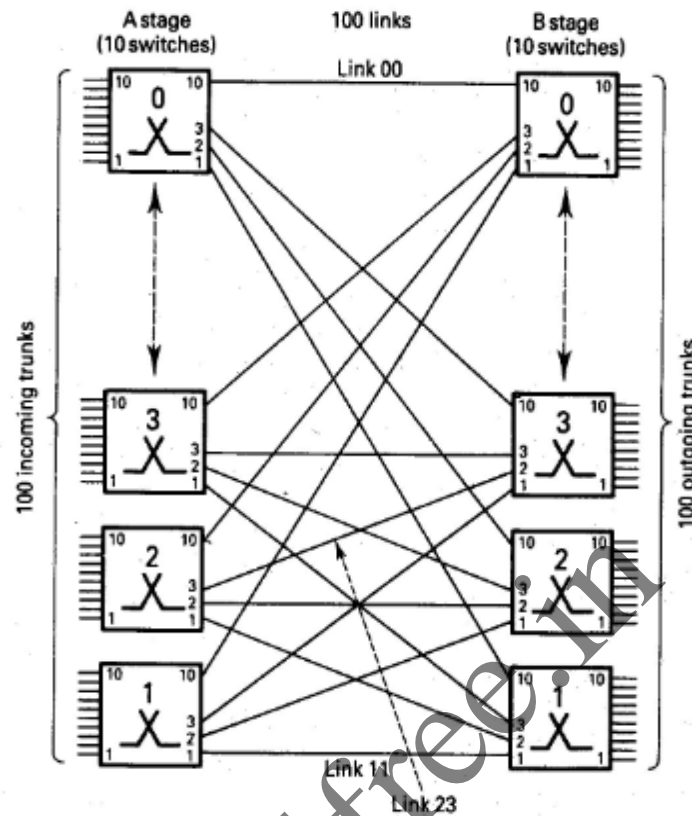

Figure 2.6 two stage link network (using switches of size 10 X 10 to interconnect 100 incoming and 100 outgoing trunks)

Marker:

Marker is used to setup a connection from a given incoming trunk to a given outgoing trunk, this also defines the link to be used and the select and bridge magnets to be operated to make the connection. Marker first test the condition of the outgoing trunk for busy/free condition of the relevant link. Only when two sides are free it operates the switches. This is called as conditional selection.

A marker has access to both ends of a connection that it sets up through a network, it can test the connection for continuity before it releases. It reports the faults in the path and attempt to set up the connection over a different path through the network.

A concentrator can be constructed by multiplying together the horizontals of a number of primary switches as shown in figure 2.7. this shows a network with 500 incoming trunks and 100 outgoing trunks using switches of size 10 X 10.

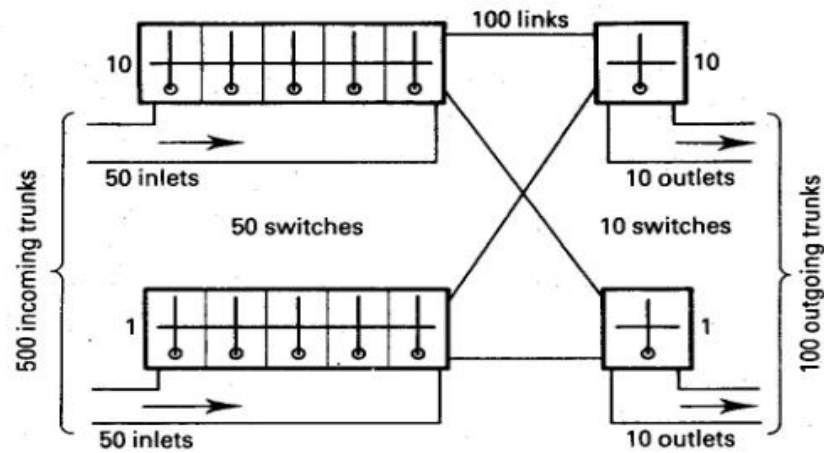

Figure 2.7. Concentrator connecting 500 incoming trunks to 100 outgoing trunks (switches 2 to 9 not shown)

To obtain larger network, four stages can be used. Figure 2.8 shows a Four stage network, constructed from 400 switches of size 10 X 10 to serve 1000 incoming and outgoing trunks.

A large crossbar exchange needs several markers in order to handle its traffic and this introduces a complication. Here it is essential to prevent two or more markers from attempting to set up connection in the same link frame at the same time. To overcome this marker in a crossbar system is using the quite complex lock out circuits.

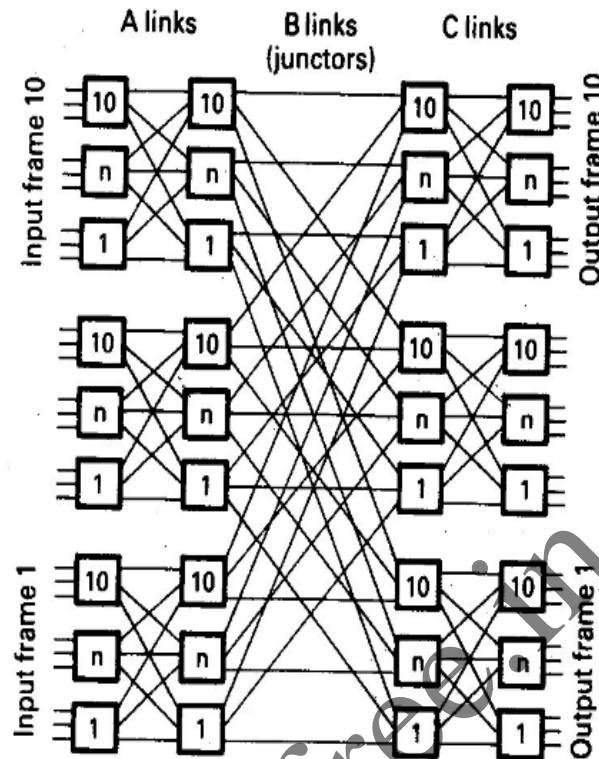

Figure 2.8 Four stage switching network for 1000 incoming trunks and 1000 outgoing trunks using 10 X 10 switches.

2.7 Electronic switching

The Electronic switching system evolved to overcome the major drawbacks of the electromechanical switching systems. Electronic exchanges have the more economic controls compared to electromechanical exchanges. The major drawbacks of the electromechanical exchanges are

- The non-flexibility of the design used.
- Wear and tear of the control switches.

In electronic exchange the life of the electronic device is independent of operation, but dependent on control parameters. Advances made in computer technology led to the development of the Stored-program control (SPC). This enables the digital computer to be used as a central control processor and perform different functions with the same hardware by executing different programs.

Any data could be altered and could be controlled by the central processor. Even few functions can be controlled by the customers. Examples include:

- Call barring: the customer can prevent unauthorized calls being made and can prevent incoming calls when they don't want to be attended.
- Repeat last call: If a line is engaged, the caller can try again later without having to redial the full number.

- Remainder calls: the exchange can be instructed to call customer at a pre-arranged time (e.g. weak-up call)
- Call diversion: the exchange can be instructed to connect calls to different number when the customer goes away.
- Three way calls: the customer can instruct the exchange to connect a third party to a call that is already in progress.
- Charge advice: this is indication call done by the exchange to the customer, to inform the call duration and charge.

In order to develop a complete electronic exchange, we replace electromechanical switches in the speech path by electronic common control.

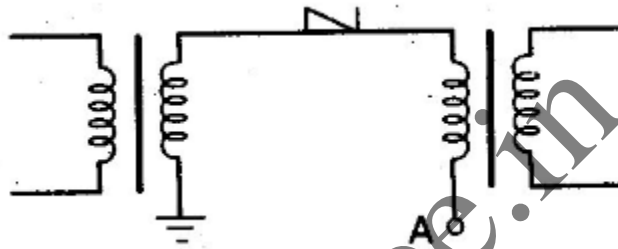

Fig 2.9 diode crosspoint

Figure 2.9 shows a diode crosspoint relay. If A is positive the diode is reverse biased and the crosspoint is open when A is negative. These electronic devices are used in the speech path.

In order to implement a crosspoint, a one bit memory along with switching element is required. Cold - Cathode gas tubes and PNP semiconductor devices are used to implement crosspoint because two functions are provided in these devices.

But cost and implementation was high and complicated which lead to the development of FDM and TDM system as a switch.

In FDM system can be used as switch by bringing the two ends of its transmission path together. Here made the modem to one end of the path to operate at fixed frequencies, but those at another end to operate for any frequencies. Now any trunk at one side of the switch can be connected to any trunk at the other side. This method is too expensive.

A TDM system can also be used as a switch. If any of the N receiving gates is operated by a train of pulses coincident with those applied to one of the N sending gates, then a transmission path is provided from the incoming trunk to outgoing trunk via a common highway.

For a transmission system, fixed pulse timings are used. By altering the pulse timings any incoming trunk is connected to any outgoing trunk i.e., N X N switch is obtained. It is cheaper method.

Types of electronic switching system

- Space division systems (SD)
- Time division system (TD)

In Space division systems each connection is made over a different path in space which exists for the duration of the connection.

In a time division system each connection is made over a same path in space but at different instant of time.

Note: Reed electronic system

2.8 Digital switching systems

The development of digital switching systems under that various phase in telecommunication switching, there are two types of switching system.

1. Space division system
2. Time division system

For which the initial 1 phase of digital transmission of a signal i.e. PCM mode of transmission .TDM transmission was being introduced for the trunk and junctions, in the form of PCM. If time division transmission is used with space-division tandem switching ,as shown in figure2.10a ,it is necessary to provide de-multiplexing equipment to demodulate every channel to audio before switching and multiplexing equipment to retransmit it after switching.

If time division switching is used as shown in figure 2.10b no multiplexing and de-multiplexing equipment is needed. A considerable economy is thereby obtained.

The evolution of Digital switching systems is shown in figure 2.11.

The trunk or tandem exchange is shown in figure 2.11a a tandem exchange has a mixture of PCM junctions and analog audio junctions, the PCM terminals equipment is needed instead for the analog junctions. The tandem exchanges have no customers' lines

The Bell No.4 ESS system and French E 10 system were first introduced for trunk network and junction switching. This has lead to the conversion of trunk network into integrated digital network (IDN), in which all transmission are digital.

Figure 2.11b shows the local exchange with space-division concentrators. This enabled cheap line circuits to be retained and a large number of subscribers to share PCM equipment to access the time division routing switch.

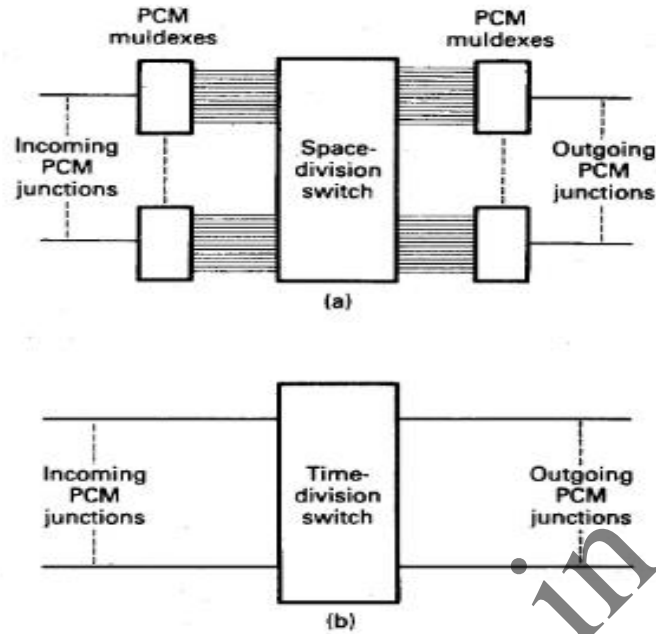

2.10 Tandem exchange with PCM junctions a)Space division switching b)time-division switching

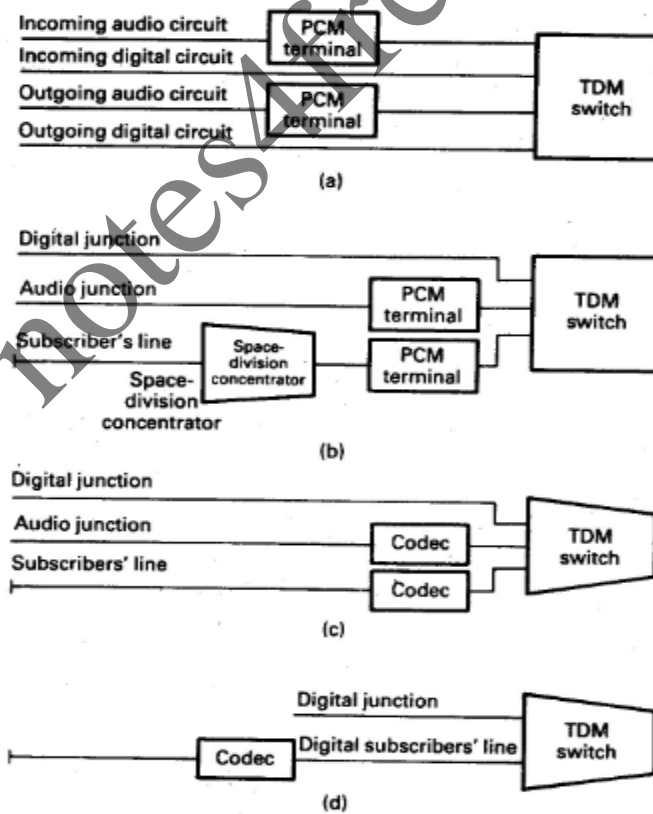

Figure 2.11 Evolution of digital switching system. (a) trunk or tandem exchange (b) Local exchange with space division concentrators. (c) Local exchange with codecs in customers' line circuits (d)Local exchange with digital customers' lines.

The evolution in semiconductor technology particularly Large-Scale Integrated circuits developed PCM coder/decoder (codec) to be manufactured on a single chip and on chip is used for one customer line. These inventions developed the SLIC.

These developments enabled electromechanical concentrators to be eliminated as shown in figure 2.11c resulting in fully digital local exchange. Examples includes

- AXE-10 system (developed in Sweden)
- The DMS-10 system (Canada)
- The E-12 system (France)
- The EWS-D system (Germany)
- No.5ESS system(USA)
- NEAX system(Japan) and
- System X (UK)

The next figure 2.11d shows the local exchange with digital customers' lines. This provides digital transmission over the customer's line; it is having number of advantages.

Subscriber line-interface circuit (SLIC):

As a result it became possible to implement all the necessary functions economically on a Subscriber line-interface circuit (SLIC), as shown in figure 2.12

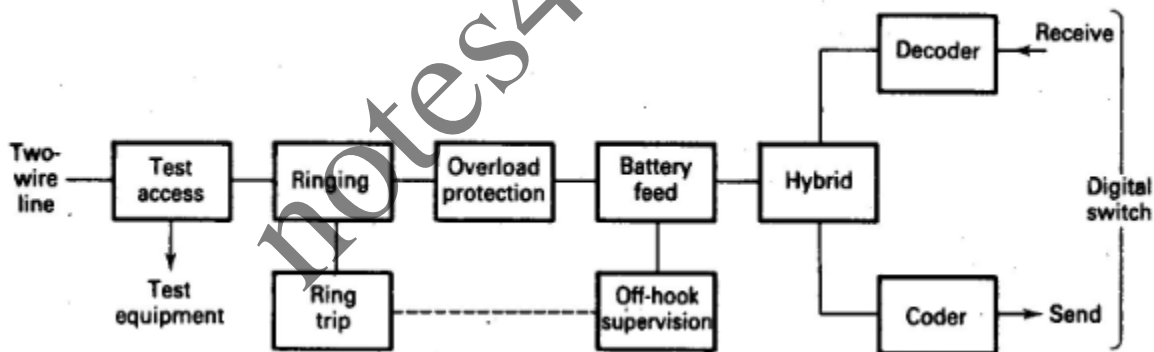

Figure 2.12 Block diagram of Subscriber line-interface circuit for a digital exchange.

The function can be summarized by the acronym BORSCHT as follows

- Battery feed
- Over-voltage protection
- Ringing
- Supervisory signaling
- Coding
- Hybrid
- Testing

Consider for data transmission, if there is an analog customer's line, a modem must be added and data can only be transmitted at relatively slow speeds. If line is digital data can be transmitted by removing the codec at higher speed. Say 64 Kbit/s instead of 2.4Kbit/s. this can include high-speed fax and slow-scan TV, in addition to speech and data.

In ISDN there are two methods of access are present

- Basic rate access → 64 Kbits/sec Speech channel, 10 Kbits/sec common channel signalling
- Primate rate access → 1.5 Mbits/sec, 1.2 Mbits/sec

The difference between these two is the speed at which the digital data is being transformed.

CHAPTER 2: DIGITAL SWITCHING SYSTEM

2.9 Introduction

The three categories of telephone system are

- Circuit switching
- Station equipment
- Transmission

2.10 Digital switching system analysis

System analysis and design is defined as the process of developing user requirement and designing systems to achieve them effectively.

An exchange or central office (e.g., PBX-private branch exchange) is a large complex system comprising many subsystems, each with unique characteristics and functionalities. In order to analyze the DSS, basic understanding of the subsystems and their functionality is necessary.

2.11 Purpose of analysis

The purpose of analyzing a DSS is to understand the reliability of the system. the modern private branch exchange (PBX) support both telephone services and internet access to the user. Due to increase in the usage of internet, the users always depend on the electronic data transfer. So in this case the DSS should be reliable, data should be secured and efficient.

Modern DSSs are very complex systems. So an engineer requires guidance in order to analyze the system. In order to understand the reliability of a DSS, a professional must know the working of the DSS along with software and hardware reliability and architecture of DSS.

To analyze the DSS understanding of the following approaches is necessary.

- Understand the architecture of the DSS; a hypothetical generic DSS is developed. This model has high-level subsystems.

- The path of some common calls through the generic DSS is traced.
- Understand the communication and control that are required for DSS.
- Understand the different types of call switching technologies used in the DSS.
- Explore the reliability models that describe the subsystems of a typical DSS.
- The software architecture of DSS along with assessment and prediction of software quality are covered.
- Operational and maintenance issues of a DSS that may impact its operational reliability are explored.
- Reliability models for network elements that interface with DSS are created.

2.12 Basic central office linkages

Basic central office (CO) and its linkages to other facilities are shown in figure 2.13

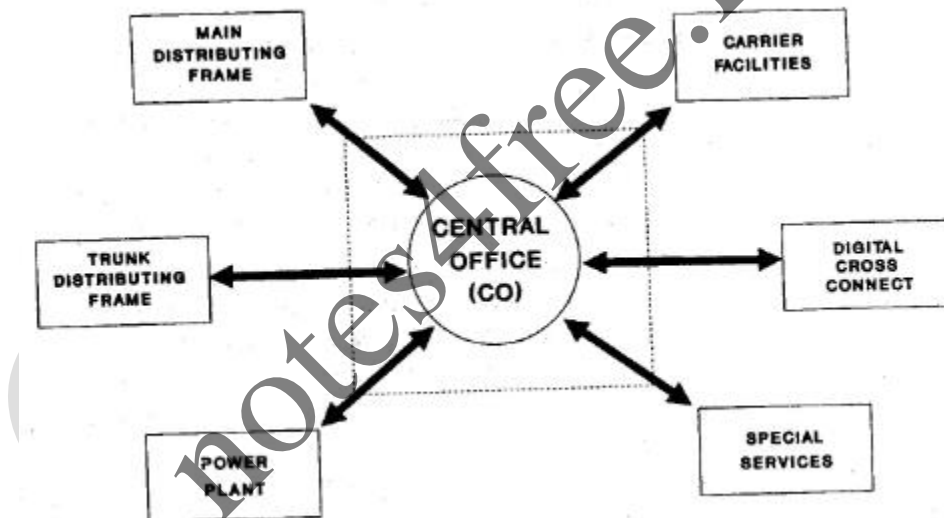

Figure 2.13 Basic Central Office Linkages

Main distribution frame (MDF): It is the location where all lines and other related links are cross connected to the CO switch. It is also called as line side of a switch.

All the lines from subscriber terminate in the MDF. It has two sides: a vertical and a horizontal. The subscriber cables terminate on the vertical side. The wiring from the DSS referred to as **line equipment** terminates on the horizontal side. The assignment process for subscriber to line equipment is usually automated.

Trunk distribution frame (TDF): It is the location where all trunks and other related links are cross connected to the CO switch. It is also called as trunk side of a switch.

All trunk cabling from different location terminates in the TDF. TDF has two sides: a vertical and a horizontal. The trunk cables terminate on the vertical side. The wiring from the DSS referred to as **trunk equipment** terminates on the horizontal side. The assignment process for trunk to trunk equipment is usually automated.

Power plant: A combination of power converters, battery systems and emergency power sources with supply basic -48- V and +24-V DC power and protected AC power to a group of CO switches.

A PDF (power distribution frame) is used to provide special voltage conversions and protections for the CO.

Carrier facilities: these provide the carrier or multiplex transmission mode between CO and with other parts of the telephone network. These facilities use co-axial cables (land or undersea) and radio and satellite systems. They terminate on TDF for cross connection to the DSS.

Digital cross connect: Digital X connect provides automatic assignment and cross connections of trunks to DSS. It can be considered a small switching system for trunks.

Special services: these services include emergency calls, customer care services and data services.

2.13 Outside plant versus inside plant

In order to analyze the DSS, the classification of the inside plant and outside plant of switching network element is necessary.

Any element of telephony equipment outside the CO box, such as MDF and carrier system, is classified as outside plant. CO equipment such as central processors, switching fabric, and tone generators, are called as inside plant.

2.14 Switching system hierarchy

Calls through the switching network follow a hierarchical path. The search for a path is through the class 5, class 4, class 3, class 2, and class 1. In addition there is international gateway offices (extension of class 1) used for international destination calls through cables, satellite, or microwave. Below figure 2.14 shows the switching system hierarchy.

Local exchange (class 5): It is also called to as End Office (EO) or Central office (CO). The purpose of class 5 is to connect the subscriber to toll centers via trunks and records the subscriber billing information.

Tandem or toll office (class 4): A class 5 Cos interfaces with the tandem offices. Class 4 switches primarily switch the trunk traffic between class 5 offices.

Primary toll centre (class 3): the class 3 switches can be directly served by the class 4 and class 5 offices, depending on the trunk deployment. Class 3 offices have the capability of storing, modifying prefixing, translating, or code converting received digits as well as finding the most efficient routing to higher-level toll offices.

Sectional toll centre (class 2): class 2 switch acts as a toll centre and can home into class 1 offices.

Regional toll centre (class 1): class 1 switch acts as a toll centre and can home into international gateway offices.

International gateway: These offices have direct access to International gateway offices in other countries. They provide international operators assistance.

Advantages: It provides the efficient way of searching path via the network.

Disadvantages: If the primary network goes down, then entire network is inaccessible.

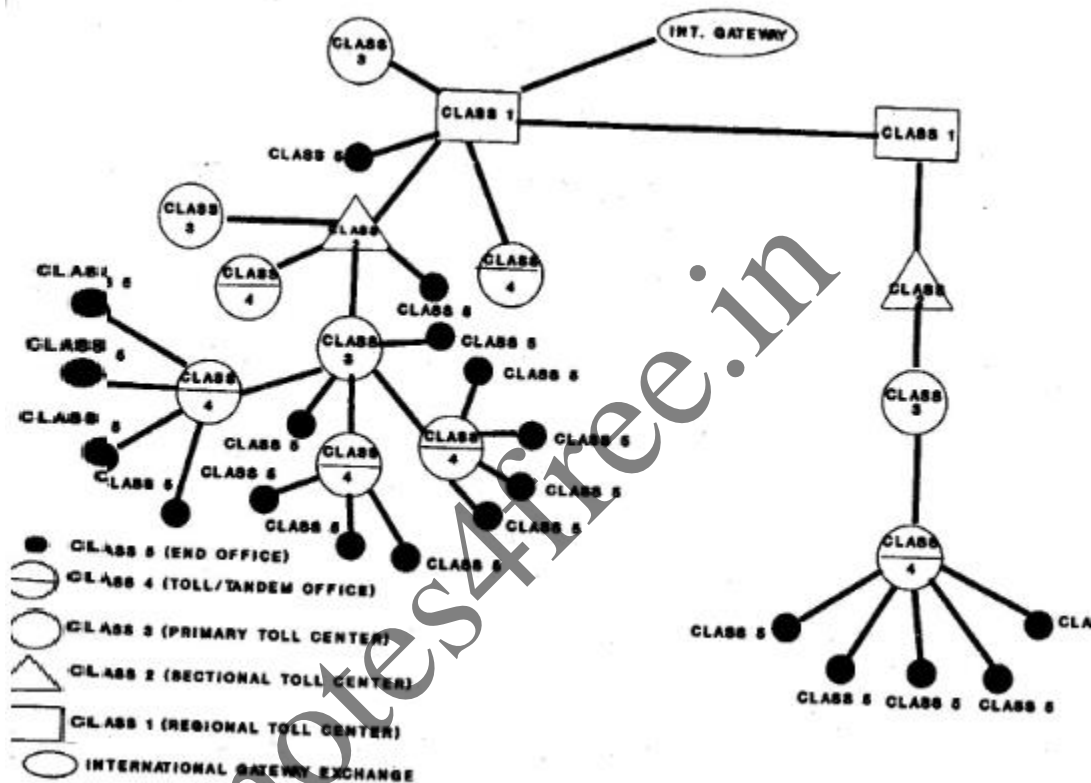

Figure 2.14 the switching system hierarchy

2.15 Evolution of digital switching systems

Most of the design concepts of DSS come from the electro-mechanical telephony switching system of the past. For instance the control structure, call handling, alternative routing, billing, etc., all evolved from earlier crossbar switching system. The early electronics system used crossbar switches as its switching matrix or switching fabric.

a) Stored program control switching systems

The modern switching systems are controlled by the microcontrollers. It is a software-controlled central processor, the control of switching function was programmed into memory and actions were executed by the control processor.

The earlier electronic switching system had temporary memory for storing transient call information and some permanent memories to carry programming information. Simplified view of telephony switch is shown in figure 2.15. It is also called as Stored Program control switching system

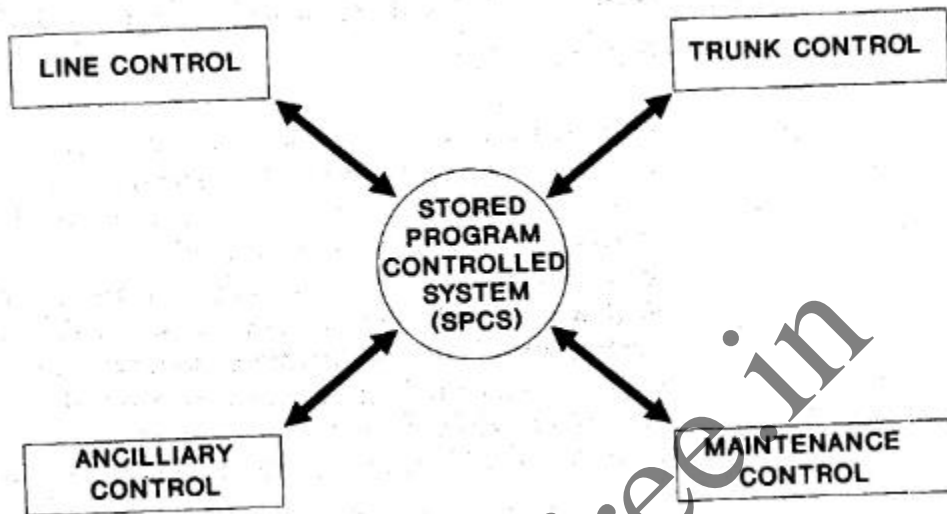

Figure 2.15 Basic control structure of a central office.

The basic function of an SPC system is to control line originations and terminations and to provide trunk routing to other central or tandem offices. SPC also controls features and functions of a CO, called as ancillary control. SPC system consists of central processor and all its peripherals are controlled by central processor. These processors were duplicated for reliability.

The modern DSS consists of a number of processors and uses distributed software and hardware architecture. The maintenance functions of a modern DSS are originated from SPC. A separate processor will take care of the maintenance functions.

b). Digital switching system fundamentals

The concept of SPC is extended to modern DSSs. The basic element of DSS is similar to that of SPC switching system. A switching system is called digital when the input and output from switching system network can directly support digital signals. A digital signal can be defined as coded pulses that can be used for signaling and control. However, analog signal can still be processed through the DSS via analog-to-digital (A/D) or digital-to-analog converters (D/A).

The evolution of digital switching from analog switching is shown in figures 2.16 (a) to (d)

Figure 2.16 (a) shows a typical analog switch with analog lines and trunks. It shows the trunk side and line side of a switch. The basic functionality of switching system is to switch lines and trunks. The main objective of the DSS is to switch the subscriber and trunk facilities.

Figure 2.16 (b) shows the next step in the evolution of the DSS. This phase uses analog lines and analog trunks but employs A/D and D/A converters for digital call processing of calls. The switching element is digital means that digital signals are sent through the switch.

Figure 2.16 (c) shows the next step in the digital switch; where digital switches talk to other digital switch using digital trunks simultaneously supporting analog lines and trunks.

Figure 2.16 (d) shows the ultimate, an all-digital linkage. Here there is no analog lines and trunks involved; all communication between digital switches via digital signaling. This plan assumes that all incoming and outgoing calls from the digital switch are digital.

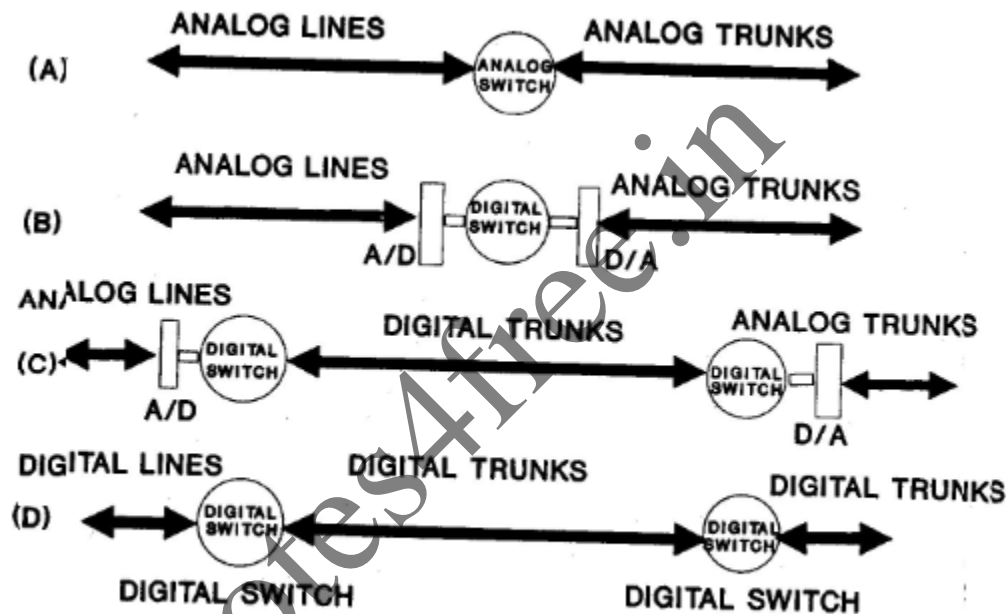

Figure 2.16 digital switch evolutions

The modern DSS supports both audio, video and internet support. So still the modern DSSs support analog and digital conversions.

Optical switching is the future of the telephony switching. Optical switching systems provide high-speed large bandwidth switching. Optical switches are under development. In case of optical switching, optical-to-electrical (O/E) and electrical-to-optical (E/O) conversions will be required.

c) Building blocks of a digital switching system:

The development of DSS model is described in four stages. The four different stages are explained below.

Stage1: Stage 1 of conceiving DSS are shown in figure 2.17a at this stage, all inputs and outputs to (i.e., lines and trunks) DSS are defined. This stage explains the very basic kernel of a DSS, with the switching

fabric. The switching fabric switches lines and trunks under the control of a central processor and network controller. Switching fabric is a “switched” path through the CO.

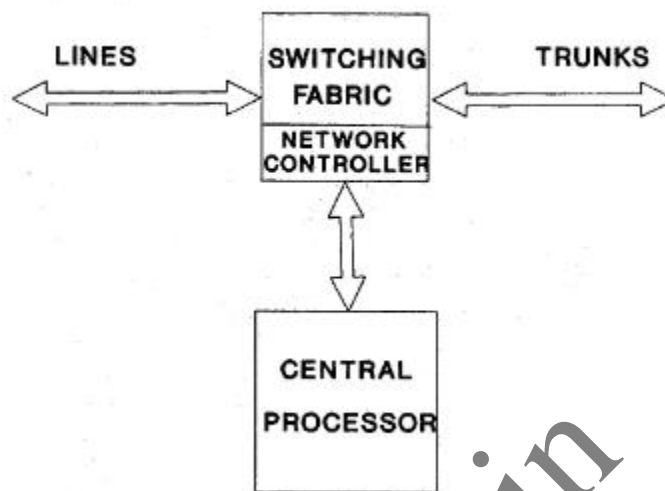

Figure 2.17a First stage with lines and trunks

Stage2: Stage 2 of a DSS is shown in figure 2.17b. The concepts of line modules (LMs) and trunk modules (TMs) are introduced here. These are building blocks of a modern DSS. The lines or trunks grouped together on circuit packs, called as line or trunk equipment, and connected to the switching fabric through a controlling interface.

Some DSS allow termination of only one line on one line module, while others allow termination of multiple lines on a single line module. Both schemes have pros and cons. The advantage of first method is, if a line module becomes defective, the line can be easily assigned to a new piece of line equipment. The disadvantage of later method is, if a line goes defective, this may impact a number of multiple lines if the line module carries multiple lines. Similar schemes used for trunk and trunk modules.

Stage3: Stage 3 of a DSS is shown in figure 2.17c. This stage introduces the concept of interface controllers for LMs and TMs and distributed processing system. This stage replaces the Network controller by Network control processors (NCP).

The task of controlling the switching fabric is usually assigned to a series of NCPs that control a part of the switching matrix and a group of LMs and TMs. The central processor controls all the network processors. Most of the DSS use the concept of central processor and the many NCP. this helps in easy increase of network size.

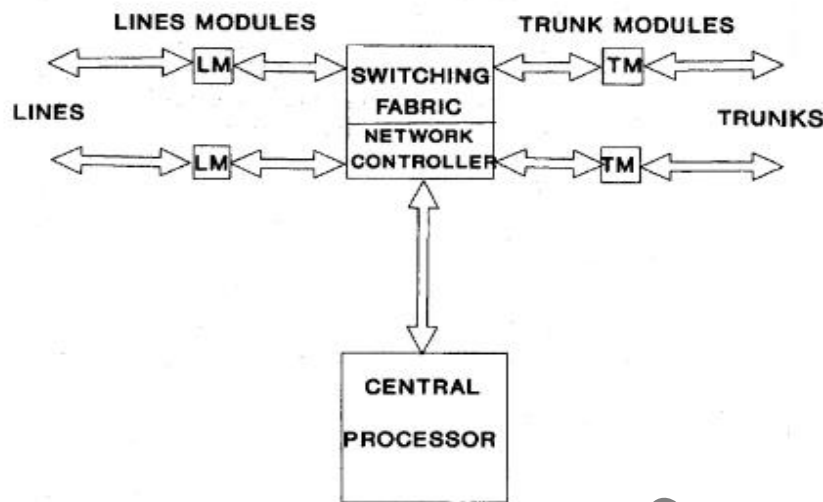

Figure 2.17b second stage with line modules and trunk modules

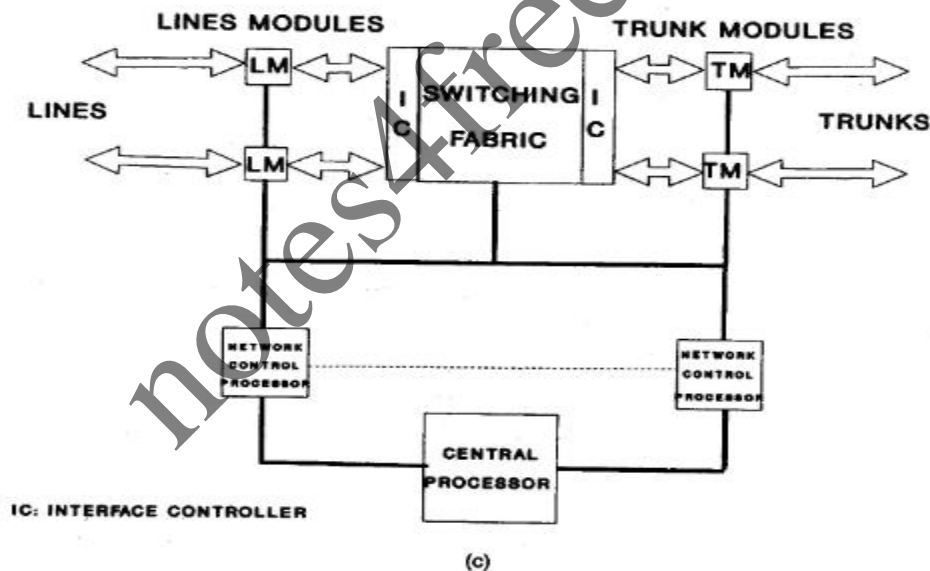

Figure 2.17c third stage with Network Control Processors

Stage4: Stage 4 is a final stage of a DSS and is shown in figure 2.17d. This level presents the high level design of a DSS equipped with interface controller and service circuits to the line and trunk modules. In reality, it is an initial model of a DSS. Here duplicated scheme is introduced. Since telephony processing is a nonstop process requires high reliability, and memory for processing the telephonic events. Interface controller connects the LMs and TMs. The purpose of the service circuits is to provide dial tone, ringing and other functions.

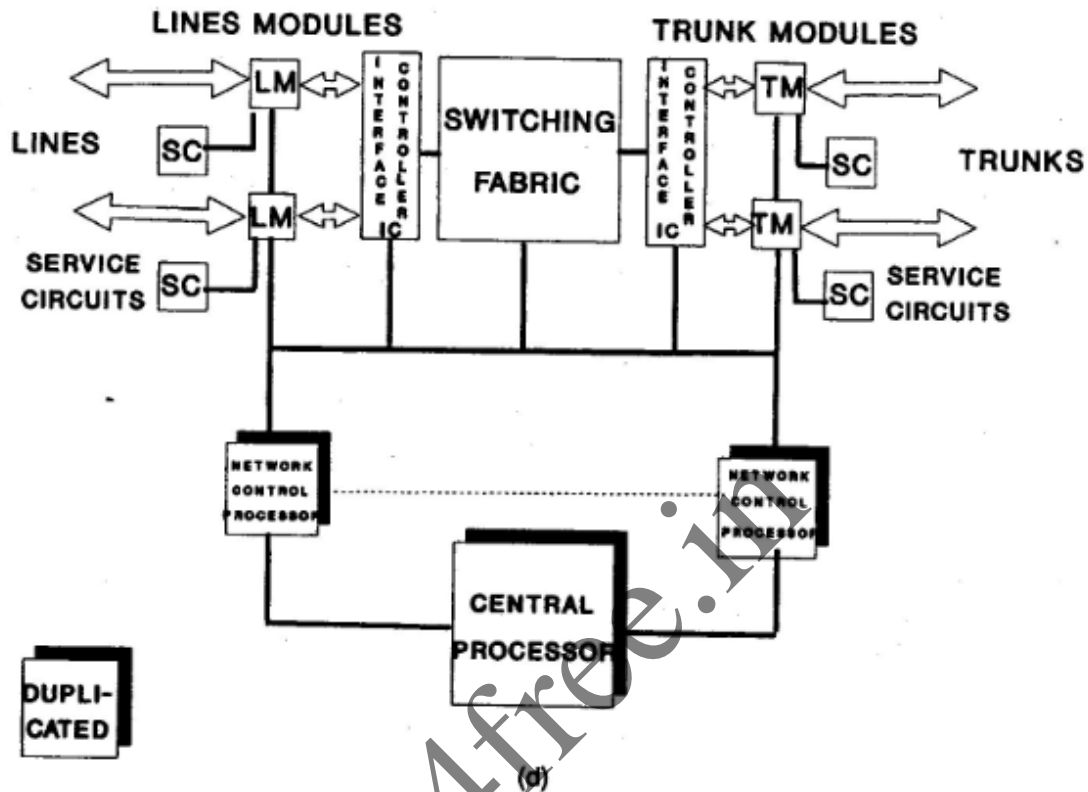

Figure 2.17d fourth stage with redundant processor

Basic call processing

There are four types of calls processed through a digital switching system. They are

- Intra-LM calls
- Inter LM calls
- Incoming calls
- Outgoing calls

Intra-LM calls: It is a call within the digital switching system (DSS). For example when a customer goes off-hook and dials a telephone number of another person who is connected to the same line module. Intra LM call path is shown in figure 2.18a

The off-hook condition is detected by the line modules and service circuit provides the dial tone to the calling customers. The LM requests the path through the switching matrix and processed by the interface controller (IC), which in turn control the network control processor to assign the path. Consequently a path is established between the called party and calling party through the switching matrix and the service circuit provides the ringing tone.

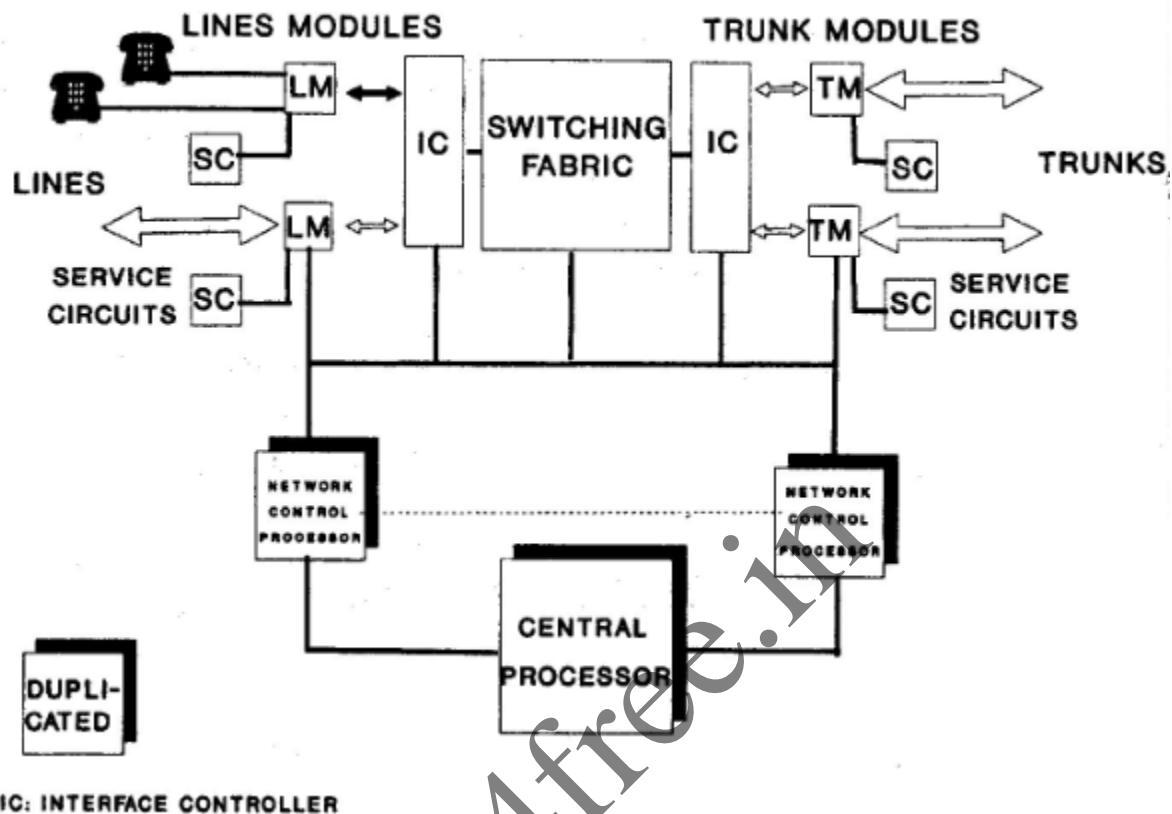

Figure 2.18a intra LM call (calls inside the line module)

Inter LM calls: Inter line module call is nothing but a call processing between two DSSs. For example when a customer goes off-hook and dials a telephone number of another person who is connected to another line module. Inter LM call path is shown in figure 2.18b

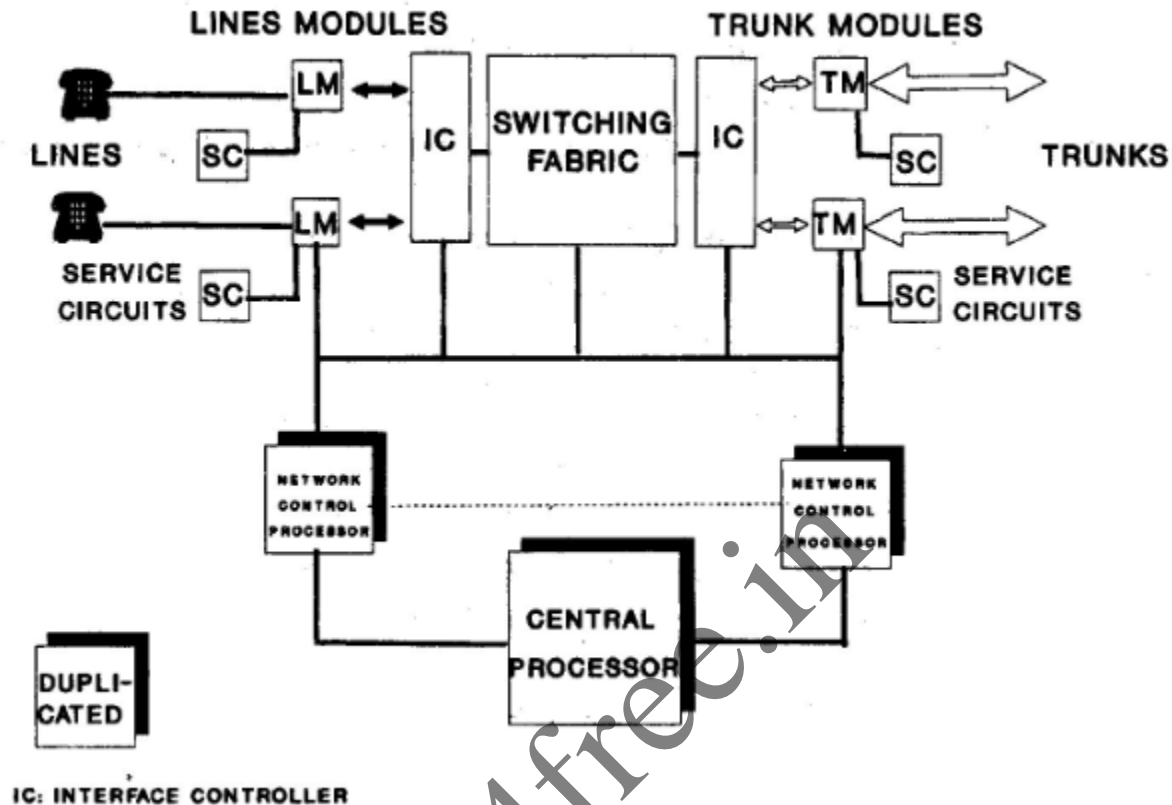

Figure 2.18b Inter LM calls (calls outside the line module)

Outgoing calls: When a line module processes a call which has terminating equipment outside the central office (CO), the LM requests for the path through the switching matrix to a trunk module via the interface controller (IC). IC works with the NCP to establish a path to an outgoing trunk. Once a path is established through the switching matrix, the trunk module (TM) connects a service circuit for the controlling the call to the called CO.

The special functions such as DTMF and out pulsing are provided trunk service circuits. An outgoing call from an originating office is an incoming call to a terminating office. The paths for the incoming and outgoing calls are shown in figure 2.18c.

Incoming calls: when a TM detects a incoming call, the trunk module requests for a path through the switching matrix from the interface controller and the NCP. Once the path is detected the switching matrix to LM that has the terminating line, the service circuit provides the ring to the called telephone equipment.

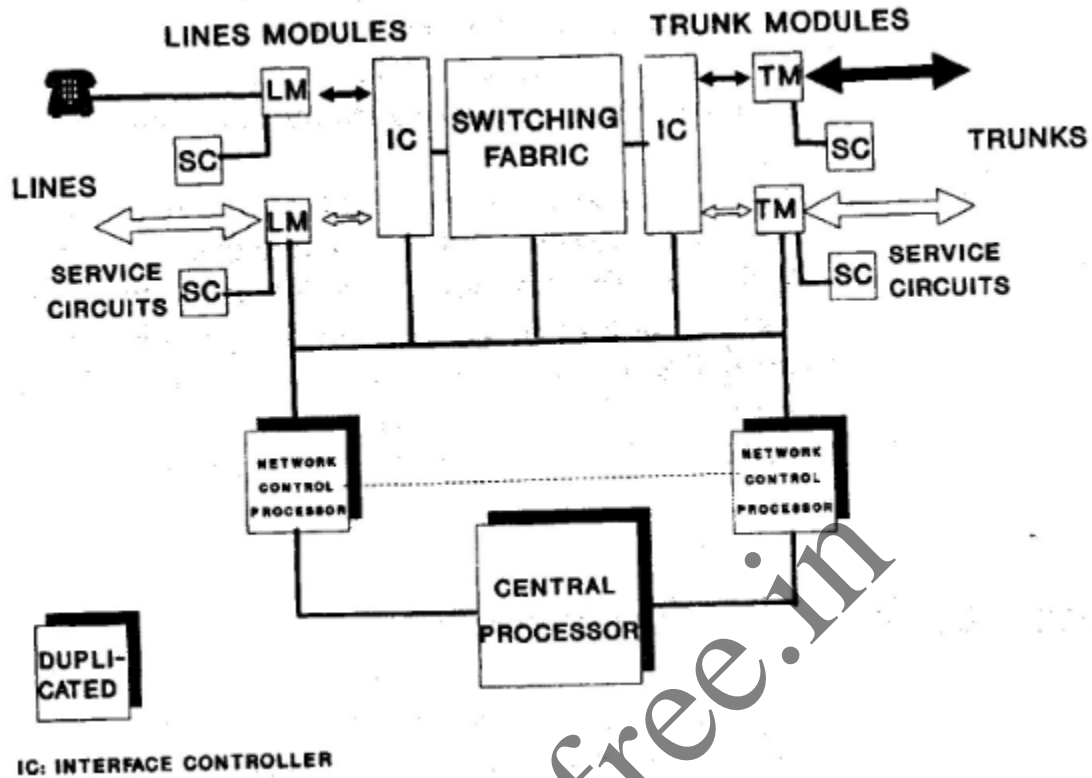

Figure 2.18c incoming / outgoing call

TEXT BOOKS:

1. Telecommunication and Switching, Traffic and Networks - J E Flood: Pearson Education, 2002.
2. Digital Switching Systems, Syed R. Ali, TMH Ed 2002.

MODULE-3

TELECOMMUNICATIONS TRAFFIC: Introduction, Unit of traffic, Congestion, Traffic measurement, Mathematical model, lost call systems, Queuing systems. **SWITCHING SYSTEMS:** Introduction, Single stage networks, Gradings, Link Systems, GOS of Linked systems. [Text-1]

8Hours

Chapter 1: TELECOMMUNICATIONS TRAFFIC:

3.1 Introduction:

- When any industrial plant is to be designed, an initial decision must be made as to its size, in order to obtain the desired throughput.
- In telecommunication system, it is the traffic to be handled. This determines the number of trunks to be provided.

Trunk:

- In teletraffic engineering, trunk is used to describe any entity that will carry one call.
- It may be an international circuit with a length of thousands of kilometers or a few meters of wire between switches in the same telephone exchange.

Trunking: the arrangement of trunks and switches within a telephone exchange is called trunking.

Traffic variation in minutes

- The figure 3.1 shows the average traffic in minutes. It shows the number of calls, in progress on a large telecommunication system (example: telephone exchange) made over a few minutes.
- Here the number of calls varies in a random manner as individual calls begin and end.

Traffic variation during a day

- Figure 3.2 shows the way in which the average traffic varies during the working day at a typical medium size telephone exchange or a transmission route.
- There are very few calls during the night.
- The number of calls rises as people go to work and reaches a maximum by the middle of the morning.
- It falls at the mid-day, as people go to home from working place and it has a further peak in the evening as people make social calls.
- Busy hour: It is a period of one hour, which corresponds to the peak traffic load. In figure 3.2 Busy hour is from 10 am to 11 am.

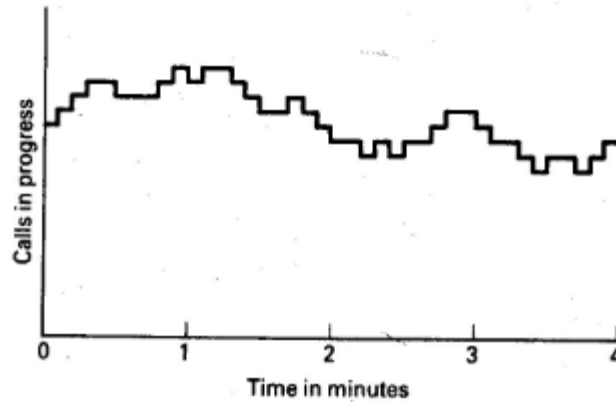

Figure 3.1 Short term traffic variation

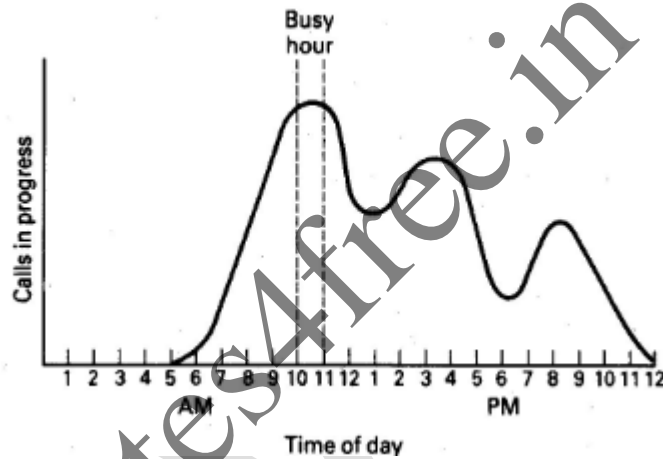

Figure 3.2 Traffic variations during a day

1.2 The unit of traffic

- Traffic intensity or simple traffic is defined as the average number of calls in progress.
- The unit of traffic is Erlang [E], named after A.K Erlang the Danish pioneer of traffic.
- On a group of trunks the average number of calls in progress depends on both the number of calls which arrive and their duration.

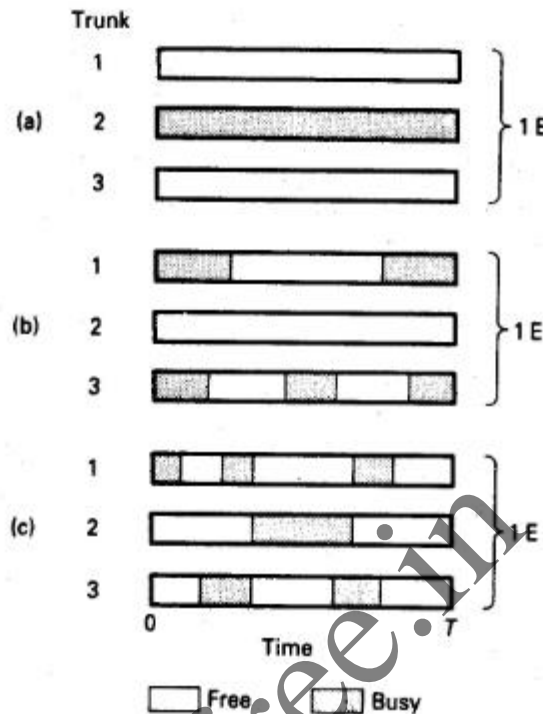

Fig 3.3 Examples of 1 Erlang of traffic carried on three trunks

Holding time:

Duration of call is often called its holding time, because its holds a trunk for that time.

The example in figure 3.3 shows how one Erlang of traffic can result from one trunk being busy all of the time, for each of two trunks being busy for half of time or from each of three trunks being busy for one third of the time as in figure a, b and c.

In North America, traffic expressed in terms of **hundreds of call seconds per hour (CCS)**.

$$1 \text{ hour} = 3600 \text{ seconds}$$

$$1 \text{ Erlang} = 36 \text{ CCS}$$

From the definition of the Erlang that the traffic carried by the group of trunk is given by

$$A = \frac{Ch}{T} \dots\dots\dots(1.1)$$

A= traffic in Erlangs

C= average number of call arrivals during time T

h= average call holding time.

If T=h, then A=C. Thus number of calls arriving during a period equal to the mean duration of the calls.

Since a single trunk cannot carry more than one call, $A \leq 1$, the traffic is a fraction of an Erlang equal to the average propagation of time for which the trunk is busy. This is called the Occupancy of the trunk.

P3.1. At certain exchange a total of 5000 calls are originated during the busy hour. If the average holding time of a call is $2\frac{1}{2}$ minutes, calculate the flow of traffic during this period.

Solution:

$$A = C * t$$

$$= \frac{5000 * 2.5}{60}$$

$$= 208.3 \text{ E}$$

P3.2. On an average during the busy hour, a company makes 120 outgoing calls of average duration 2 minutes. It receives 200 incoming calls of average duration 3 minutes. Find the

- Outgoing traffic
- Incoming traffic
- Total traffic

$$A_{OG} = \frac{\text{out going Calls} * h}{t} = \frac{120 * 2}{60} = 4 \text{ E}$$

$$A_{IC} = \frac{\text{Incoming Calls} * h}{t} = \frac{200 * 3}{60} = 10 \text{ E}$$

Total traffic = outgoing traffic + incoming traffic

$$= 4 + 10$$

$$= 14 \text{ E}$$

P3.3: During the busy hour, on average, a customer with a single telephone line makes three calls and receives three calls. The average call duration is 2 minutes. What is the probability that a caller will find the line engaged?

Occupancy of line: $(3+3) * 2 / 60 = 0.1 \text{ E} = \text{Probability of finding the line engaged.}$

3.3 Congestion

The situation, where all the trunks in a group of trunks are busy, and so it can accept no further calls, this state is known as congestion.

In message switching system, calls that arrive during congestion wait in a queue until an outgoing trunk becomes free. Thus they are delayed but not lost, such systems are queuing or delay system.

In circuit switching system (example: telephone exchange), all attempts to make a call over a congested group of trunks are unsuccessful, such systems are called as lost-call systems.

In lost call system

$$\text{Traffic Carried} = \text{traffic offered} - \text{traffic lost}$$

The proportion of calls that is lost or delayed due to congestion is a measure of the service provided. It is called as grade of service (B). For a lost call system, the grade of service, B can be defined as:

$$B = \frac{\text{Number of calls lost}}{\text{Number of calls offered}}$$

Hence, also:

$$B = \frac{\text{Traffic lost}}{\text{Traffic offered}}$$

= Proportion of the time which congestion exists

= Probability of congestion

= Probability that a call will be lost due to congestion

Thus, if traffic A Erlangs is offered to a group of trunks having grade of service B, the traffic lost is AB and the traffic carried = A - AB = A(1-B) Erlangs

The larger the grade of service, the worse is the service given. The grade of service is normally specified for the traffic at the busy hour. At other times it is much better.

In practice, busy hour GOS can vary from, 1 in 1000 for cheap trunks inside an exchange to 1 in 100 for interexchange connections and 1 in 10 for expensive international routes.

Dimensioning problem: It is the basic problem of determining the size of a telecommunication system.

P3.4: During the busy hour, 1200 calls were offered to a group of trunks and six calls were lost. The average call duration was 3 minutes. Find:

1. the traffic offered
2. the traffic carried
3. the traffic lost
4. the grade of services
5. the total duration of the periods of congestions

Solutions:

$$\text{Traffic carried: } A = \frac{C * h}{T} = \frac{1200 * 3}{60} = 60E$$

$$\text{Traffic offered: } A = \frac{C * h}{T} = \frac{1194 * 3}{60} = 59.7E$$

$$\text{Traffic lost: } A = \frac{C * h}{T} = \frac{6 * 3}{60} = 0.3E$$

$$B = \text{GOS} = \text{traffic lost} / \text{traffic carried} = 0.3 / 60 = 0.005$$

The total duration of periods of congestion = $0.005 * 3600 = 18$ Seconds

3.4 Traffic measurement

- It means that measuring of busy hour traffic is necessary & regularly operating company need to measure and must keep records.
- By definition, measuring the traffic carried amounts to counting calls in progress at regular intervals during the busy hour and averaging results
- In the past, engineers counted the plugs inserted in a manual switchboard or the number of selector-off normal in an automatic exchange by *peg count or switch count* method. Later automatic traffic records were used in automatic exchange.
- In modern stored program controlled system, the central processors generate records of the calls that they set up.

P3.5: Observations were made of the number of busy lines in a group of junctions at intervals of 5 minutes during the busy hour. The results obtained were: 11,13,8,10,14,12,7,,15,17,16,12

It is therefore estimated that the traffic carried, in Erlangs was:

$$\frac{11+13+8+10+14+12+7+9+15+1+16+12}{12} = 12E$$

3.5 A mathematical model

To obtain analytical solutions to teletraffic problems it is necessary to have a mathematical model of the traffic offered to telecommunication system.

A simple model is based on the following assumptions

- Pure chance traffic
- Statistical equilibrium

Pure chance traffic: The assumption of pure chance traffic means that call arrivals and call terminations are independent random events. Sometimes it is also called as Poissonian traffic.

If call arrivals are independent random events, their occurrence is not affected by previous calls. Sometimes traffic is called as memoryless traffic.

This assumption of random call arrivals & termination leads to the following results.

1. The number of call arrivals in a given time has a Poisson distribution i.e.

$$P(x) = \frac{\mu^x}{x!} e^{-\mu}$$

Where x is the number of call arrivals in a given time T and μ is the mean number of call arrivals in time T . For this reason, pure-chance traffic is also called Poissonian traffic.

- The intervals, T , between call arrivals are the intervals between independent random event. These intervals have a negative exponential distribution, i.e.,

$$P(T \geq t) = e^{-t/\bar{T}}$$

Where \bar{T} is the mean interval between call arrivals.

- Since the arrival of each call and also the intervals between two random events, call durations, T , are also the intervals between two random events and have a negative exponential distribution, i.e.,

$$P(T \geq t) = e^{-t/h}$$

Where h is the mean call duration (holding time)

The intervals, T , between call arrivals are the intervals between independent random events, have a negative exponential distribution i.e.

Since the arrival of each call and its termination are independent random events, call duration, T are also intervals between two random events have a negative exponential distribution i.e.,

Statistical equilibrium: The assumption of Statistical equilibrium means that the generation of traffic is a stationary random process i.e., probabilities do not change during the period being considered. Consequently the mean number of calls in progress remains constant.

Statistical equilibrium is not obtained immediately before the busy hour, when the calling rate is increasing nor at the end of the busy hour, when calling rate is falling.

P3.6: On average one call arrives every 5 seconds. During a period of 10 seconds, what is the probability that:

- No call arrives?
- One call arrives?
- Two call arrives?
- More than two calls arrive?

$$P(x) = \frac{\mu^x}{x!} e^{-\mu}, \text{ Where } \mu = 2$$

- $P(0) = \frac{2^0}{0!} e^{-2} = 0.135$
- $P(1) = \frac{2^1}{1!} e^{-2} = 0.270$
- $P(2) = \frac{2^2}{2!} e^{-2} = 0.270$
- $P(>2) = 1 - P(0) - P(1) - P(2)$
 $= 1 - 0.135 - 0.270 - 0.270$
 $= 0.325$

P3.7 In a telephone system the average call duration is 2 minutes. A call has already lasted 4 minutes. What is the probability that:

1. The call will last at least another 4 minutes?
2. The call will end within the next 4 minutes?

These probabilities can be assumed to be independent of the time which has already elapsed?

1. $P(T \geq t) = e^{-t/h} = e^{-2} = 0.135$
2. $P(T \leq t) = 1 - P(T \geq t) = 1 - 0.135 = 0.865$

State transition diagram for N trunks

When we have N trunks the number of calls in progress varies randomly as shown in figure 3.4. It is an example of Birth and death process also called as **renewal process**. The number of calls in progress is always between 0 and N. Thus it has N+1 states and its behavior depends on the probability of change from each state to the one above and to the one below it. This is called as **simple Markov chain** as shown in figure 3.4.

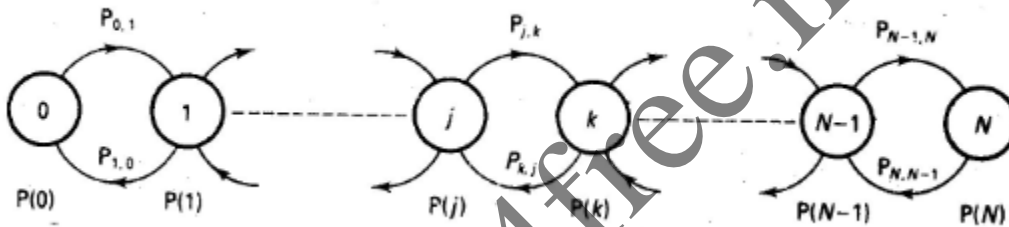

Fig 3.4 state transition diagram for N trunks

In figure P(j) is the probability of state j and P(k) is the probability of the next state higher state k, P_{j,k} is the probability of a state increase to k, given that the present state is j. P_{k,j} is the probability of a decrease to j, given that the present state is k. The probabilities P(0), P(1),.....P(N) are called the state probabilities and the conditional probabilities P_{j,k} P_{k,j}, are called the transition probabilities of the Markov chain. If there is statistical equilibrium, these probabilities do not change and the process is said to be a regular Markov chain.

If there is statistical equilibrium, these probabilities do not change and process is said to be a regular Markov chain.

Consider a very small interval of time δt , starting at time t. Since δt is very small, the probability of something happening during it is small. The probability of two or more events during δt , is negligible. The events which can happen during δt are thus as follows.

One call arriving, with probability P(a).

One call ending, with probability P(e).

No change, with probability 1-P(a)-P(e).

W. k. t the traffic carried by a group of trunk is given by

$$A = \frac{Ch}{T} \dots (1.1),$$

Then the mean number of calls arriving during the average holding time, h is C=A. Thus the mean number arriving during time One call arriving, with probability δt is $A\delta t/h \ll 1$ and represents the probability, P(a), of a call arriving during δt .

$$P_{j,k} = P(a) = A\delta t/h \dots (1.2)$$

If the mean holding time is h and the number of calls in progress is k, one expects an average of k calls to end during a period h. The average number of calls ending during δt is therefore $k\delta t/h$. Since δt is very small $k\delta t/h \ll 1$ and represents the probability, P(e), of a call ending during δt .

$$P_{k,j} = P(e) = k\delta t/h \dots (1.3)$$

If the probability of j calls in progress at time t is P(j), then the probability of a transition from j to k busy trunks during δt is:

$$P(j \rightarrow k) = P(j) P(a) = P(j) A\delta t/h \dots (1.4)$$

If the probability of k calls in progress at time t is P(k), then the probability of a transition from k to j busy trunks during δt is:

$$P(k \rightarrow j) = P(k) P(e) = P(k) k\delta t/h \dots (1.5)$$

The assumption of statistical equilibrium requires that $P(j \rightarrow k) = P(k \rightarrow j)$. Otherwise the number of calls in progress would steadily increase or decrease. Thus, from equations (1.4) and (1.5)

$$k P(k) \delta t/h = A P(j) \delta t/h$$

$$P(k) = \frac{A}{k} P(j) \dots (1.6)$$

Hence: $P(1) = \frac{A}{1} P(0)$

$$P(2) = \frac{A}{2} P(1) = \frac{A^2}{2 \cdot 1} P(0)$$

$$P(3) = \frac{A}{3} P(2) = \frac{A^3}{3 \cdot 2 \cdot 1} P(0)$$

And, in general:

$$P(x) = \frac{A^x}{x!} P(0) \dots (1.7)$$

The assumption of pure chance traffic implies a very large number of sources. Thus, x can have any value between zero and infinity and the sum of their probabilities must be unity. Then

$$1 = \sum_{x=0}^{\infty} P(x) = \sum_{x=0}^{\infty} \frac{A^x}{x!} P(0) = e^A P(0)$$

$$P(0) = e^{-A}$$

$$P(x) = \frac{A^x}{x!} e^{-A}$$

Thus, if call arrivals have a Poisson distribution, so does the number of calls in progress. This requires an infinite number of trunks to carry the calls. If the number of trunks available is finite, then some calls can be lost or delayed and the distribution is no longer Poissonian.

3.6 Lost call systems

Theory:

Erlang determined the grade of service (i.e. the loss probability) of a lost call system having N trunks when offered traffic A as shown in figure 3.5

The solution depends on the following assumptions

- Pure chance traffic
- Statistical equilibrium
- Full availability
- Calls encounter during congestion are lost.

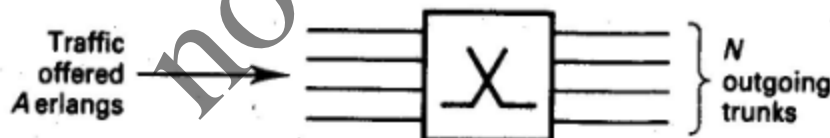

Fig 3.5 Lost call system

The pure chance traffic implies that call arrivals and call terminations are independent random events.

The Statistical equilibrium implies that probabilities do not change.

Full availability means that every call that arrives can be connected to any outgoing trunk which is free. If the incoming calls are connected to the outgoing trunks by switches, switches must have sufficient outlets to provide access to every outgoing trunk.

The lost-call assumption implies that any attempted calls which encounter congestion are immediately cleared from the system.

Here we are assuming that the traffic offered is the total arising from all successful and unsuccessful calls.

If there are x calls in progress, then equation (1.7) gives

$$P(x) = \frac{A^x}{x!} P(0)$$

However, there cannot be a negative number of calls and there cannot be more than N. Thus, we know with certainty that $0 \leq x \leq N$.

$$\sum_{x=0}^N P(x) = 1 = \sum_{x=0}^N \frac{A^x}{x!} P(0)$$

Hence,
$$P(0) = \frac{1}{\sum_{x=0}^N \frac{A^x}{x!}}$$

Substituting in equation (1.7) gives:

$$P(x) = \frac{A^x / x!}{\sum_{k=0}^N \frac{A^k}{k!}} \dots\dots\dots (1.8)$$

This is called first Erlang distribution/Erlang’s lost call formula.

$P(N)$, Since this is the probability of congestion, i.e., the probability of a lost call, which is the grade of service B, This is given the symbol $E_{1,N}(A)$ which denotes the loss probability for a full availability group of N trunks offered traffic A Erlangs.

$$B = E_{1,N}(A) = \frac{A^N / N!}{\sum_{k=0}^N \frac{A^k}{k!}} \dots\dots\dots (1.9)$$

Equation 1.9 is a special case of equation (1.8)

The grade of service of a loss system with N full availability trunks, offered A *erlangs* of traffic, is given by $E_{1,N}(A)$.

$$B = E_{1,N-1} = \frac{A^{N-1} / (N-1)!}{\sum_{k=0}^{N-1} \frac{A^k}{k!}}$$

$$\sum_{k=0}^N \frac{A^k}{k!} = \frac{A^{N-1} / (N-1)!}{E_{1,N-1}(A)} + \frac{A^N}{N!}$$

Substituting in equation (1.9)

$$E_{1,N-1}(A) = \frac{AE_{1,N-1}(A)}{N + AE_{1,N-1}(A)}$$

Since $E_{1,0} = 1$, this iterative formula enables $E_{1,N(A)}$ to be computed for all values of N. Table shows values $E_{1,N(A)}$.

P3.8: A group of five trunks is offered 2 E of traffic. Find:

1. The grade of service
2. The probability that only one trunk is busy
3. The probability that only one trunk is free
4. The probability that at least one trunk is free.

$$B = E_{1,N}(A) = \frac{A^N / N!}{\sum_{k=0}^N \frac{A^k}{k!}}$$

$$B = E_{1,N}(A) = \frac{2^5 / 120}{1 + \frac{2}{1} + \frac{4}{2} + \frac{8}{6} + \frac{16}{24} + \frac{32}{120}} \text{ for } N=5, A=2$$

$$= \frac{0.2667}{7.2667} = 0.037$$

From equation (1.8) $P(1) = 2/7.2667 = 0.275$

$$P(4) = \frac{16/24}{7.2667} = 0.0917$$

$$P(x < 5) = 1 - P(5) = 1 - B = 1 - 0.037 = 0.963$$

P3.9 A group of 20 trunks provides a grade of service of 0.01 when offered 12E of traffic.

1. How much is the grade of service improved if one extra trunk is added to the group?
2. How much does the grade of service deteriorate if one trunk is out of service?

$$E_{1,21}(12) = \frac{12 * E_{1,20}(12)}{21 + 12E_{1,20}(12)}$$

$$= \frac{12 * 0.01}{21 + 12 * 0.01} = 0.0057$$

$$E_{1,20}(12) = 0.01 = \frac{12 * E_{1,19}(12)}{20 + 12E_{1,19}(12)} = 0.2 + 0.12E_{1,19}(12) = 12E_{1,19}(12)$$

$$E_{1,19}(12) = 0.017$$

Traffic performance:

If the offered traffic, A, increases, the number of trunks, N, must obviously be increased to provide a given grade of service. However, for the same trunk occupancy the probability of finding all trunks busy is less for a large group of trunks than for a small one, i.e. the large group is more efficient. This is shown by figure 3.6. For a grade of service of 0.002 (i.e. one

lost call in 500). For example, 2E of traffic requires seven trunks and their occupancy is 0.27E. However, 20E requires 32 trunks and their occupancy is 0.61E.

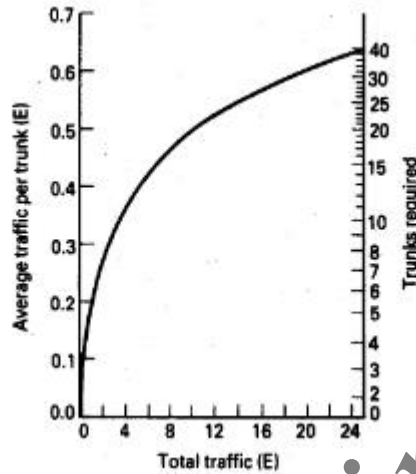

Fig 3.6 Trunk occupancies for full availability groups of various sizes (Grade of services =0.002)

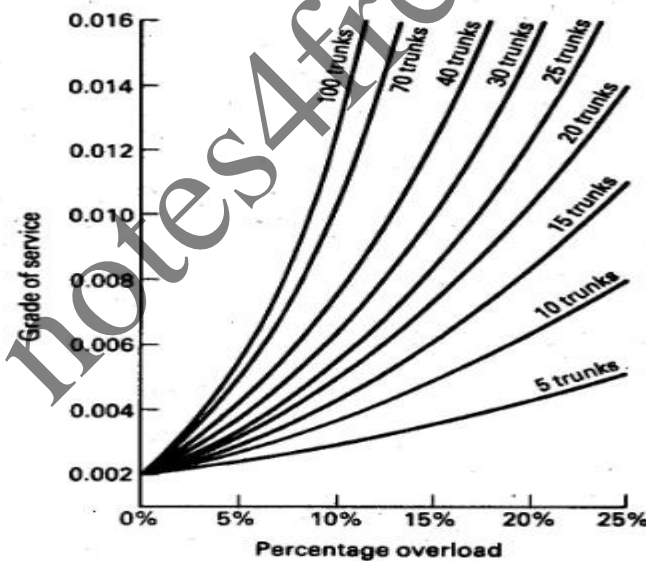

Fig 3.7 effect of overload on grade of service

The penalty paid for the high efficiency of large group of trunks is that the grade of service (GOS) deteriorates more with traffic overloads than for small Groups of trunks. Figure 3.7 shows the variation of grade of service with respect to offered traffic for different sizes of group, which were all dimensioned to provide a GOS of 0.002 at their normal traffic load. For a group of five trunk, a 10% overload increases the GOS by 40%, However, for a group of 100 trunks, it causes the GOS to increase by 550%.

For the above reason the Digital switching system operating companies uses a two criteria. Two grade of service are:

- 1) Normal criteria: for nominal traffic load.
- 2) Overload criteria: Larger GOS for normal load and overload

Sequential Selection:

In many switching systems, trunks in a group are selected by means of sequential search. A call is not connected to trunk number 2 unless number 1 is busy. It is not connected to number 3 unless both number 1 and number 2 are busy and so on.

Call finding the last choice trunk is busy or lost. As a result, the first trunk has a very high occupancy and the traffic carried by subsequent trunk is less. The last choice trunk is very highly loaded indeed.

The behavior is shown in figure 3.8. The performance of such an arrangement can be analyzed as follows. Let traffic A Erlangs be offered to the group of trunks. From equation (3.9) the GOS of a single- trunk is

$$E_{1,1}(A) = A/1+A$$

Traffic overflowing from the first trunk to the second is

$$A E_{1,1}(A) = A^2/1+A$$

Therefore traffic carried by the first trunk is

$$\text{Traffic offered} - \text{traffic lost} = A - A^2/1+A = A/1+A$$

In general traffic carried by k th trunk = Traffic lost from group of first $k-1$ trunks – Traffic lost from group of first k trunk

$$= A [E_{1,k-1}(A) - E_{1,k}(A)]$$

The traffic offered to first trunk is Poissonian. Traffic overflowing to the second trunk is more peaky.

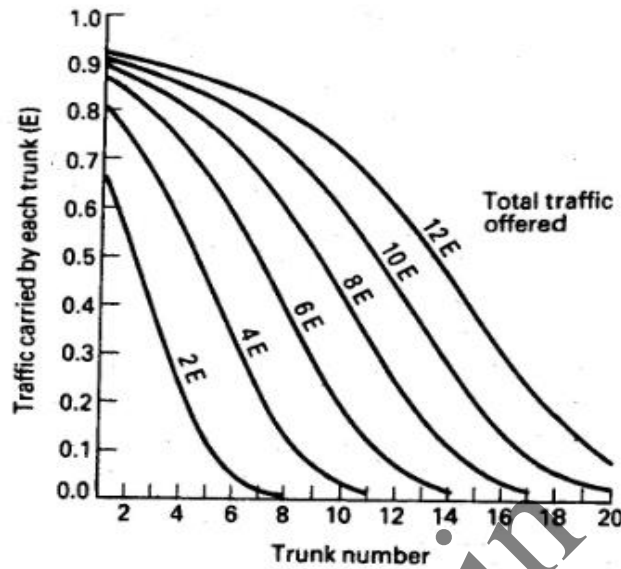

Fig 3.8 Distribution of traffic over trunks of a group with sequential search

P3.11: If sequential is used for the group of trunks five trunks is offered 2E of traffic. Then how much is the traffic carried by

1. The first choice trunk?
2. The last choice trunk?

1. The traffic carried by the first choice trunk is:

$$A/1+A = 2/(1+2) = 0.67E$$

$$E_{1,5}(2) = B = E_{1,N}(A) = \frac{32/120}{1 + \frac{2}{1} + \frac{4}{2} + \frac{8}{6} + \frac{16}{24} + \frac{32}{120}} \text{ for } N=5, A=2$$

$$= \frac{0.2667}{7.2667} = 0.037$$

$$E_{1,4}(2) = \frac{16/24}{1 + \frac{2}{1} + \frac{4}{2} + \frac{8}{6} + \frac{16}{24}} \text{ for } N=4, A=2$$

Traffic carried by the last choice trunk = 2 (0.095 - 0.037) = 0.12E.

Loss systems in tandem

GOS of several links in tandem is explained below. For connections consisting of two links, having grade of service B1, B2, is offered traffic A Erlangs, then:

Traffic offered to second link = A(1-B1)

therefore reaching destination = A(1-B1)(1-B2)

$$= A (1+B1B2-B1-B2)$$

And the overall grade of service is B=B1+B2-B1B2

If $B_1, B_2 \ll 1$, as they should be, then B_1, B_2 is negligible and overall grade of service is simply $B = B_1 + B_2$

In general for n-trunk connection, we may write

$$B = \sum_{k=1}^n B_k$$

Use of traffic tables:

Table 3.1: Traffic capacity table for full- availability groups

Number of trunks	1 lost call in				Number of trunks	1 lost call in			
	50 (0.02)	100 (0.01)	200 (0.005)	1000 (0.001)		50 (0.02)	100 (0.01)	200 (0.005)	1000 (0.001)
	E	E	E	E	E	E	E	E	
1	0.020	0.010	0.005	0.001	51	41.2	38.8	36.8	33.4
2	0.22	0.15	0.105	0.046	52	42.1	39.7	37.6	34.2
3	0.60	0.45	0.35	0.19	53	43.1	40.6	38.5	35.0
4	1.1	0.9	0.7	0.44	54	44.0	41.5	39.4	35.8
5	1.7	1.4	1.1	0.8	55	44.0	42.4	40.3	36.7
6	2.3	1.9	1.6	1.1	56	45.9	43.3	41.2	37.5
7	2.9	2.5	2.2	1.6	57	46.9	44.2	42.1	38.3
8	2.6	3.2	2.7	2.1	58	47.8	45.1	43.0	39.1
9	4.3	3.8	3.3	2.6	59	48.7	46.0	43.9	40.0
10	5.1	4.5	4.0	3.1	60	49.7	46.9	44.7	40.8
11	5.8	5.2	4.6	3.6	61	50.6	47.9	45.6	41.6
12	6.6	5.9	5.3	4.2	62	51.6	48.8	46.5	42.5
13	7.4	6.6	6.0	4.8	63	52.5	49.7	47.4	43.4
14	8.2	7.4	6.6	5.4	64	53.4	50.6	48.3	44.1
15	9.0	8.1	7.4	6.1	65	54.4	51.5	49.2	45.0
16	9.8	8.9	8.1	6.7	66	55.3	52.4	50.1	45.8
17	10.7	9.6	8.8	7.4	67	56.3	53.3	51.0	46.6
18	11.5	10.4	9.6	8.0	68	57.2	54.2	51.9	47.5
19	12.3	11.2	10.3	8.7	69	58.2	55.1	52.8	48.3
20	13.2	12.0	11.1	9.4	70	59.1	56.0	53.7	49.2
21	14.0	12.8	11.9	10.1	71	60.1	57.0	54.6	50.1
22	14.9	13.7	12.6	10.8	72	61.0	58.0	55.5	50.9
23	15.7	14.5	13.3	11.5	73	62.0	58.9	56.4	51.8
24	16.6	15.3	14.1	12.2	74	62.9	59.8	57.3	52.6
25	17.5	16.1	15.0	13.0	75	63.9	60.7	58.2	53.5
26	18.4	16.9	15.8	13.7	76	64.8	61.7	59.1	54.3
27	19.3	17.7	16.6	14.4	77	65.8	62.6	60.0	55.2
28	20.2	18.6	17.4	15.2	78	66.7	63.6	60.9	56.1
29	21	19.3	18.2	15.9	79	67.7	64.5	61.8	56.9
30	22.0	20.4	19.0	16.7	80	68.6	65.4	62.7	57.7
31	22.9	21.2	19.8	17.4	81	69.6	66.3	63.6	58.7
32	23.7	22.1	20.6	18.2	82	70.5	67.2	64.5	59.5
33	24.7	23.0	21.4	18.9	83	71.5	68.1	65.4	60.4
34	25.6	23.8	22.3	19.7	84	72.4	69.1	66.3	61.3
35	26.5	24.6	23.1	20.5	85	73.4	70.1	67.2	62.1
36	27.4	25.5	23.9	21.3	86	74.4	71.0	68.1	63.0
37	28.3	26.4	24.8	22.1	87	75.4	71.9	69.0	63.9
38	29.3	27.3	25.6	22.9	88	76.3	72.8	69.9	64.8
39	30.1	28.2	26.5	23.7	89	77.2	73.7	70.8	65.6
40	31.0	29.0	27.3	24.5	90	78.2	74.7	71.8	66.6
41	32.0	29.9	28.2	25.3	91	79.2	75.6	72.7	67.4
42	32.9	30.8	29.0	26.1	92	80.1	76.6	73.6	68.3
43	33.8	31.7	29.9	26.9	93	81.0	77.5	74.3	69.1
44	34.7	32.6	30.8	27.7	94	81.9	78.4	75.4	70.0
45	35.6	33.4	31.6	28.5	95	82.9	79.3	76.3	70.9
46	36.6	34.3	32.5	29.3	96	83.8	80.3	77.2	71.8
47	37.5	35.2	33.3	30.1	97	84.8	81.2	78.2	72.6
48	38.4	36.1	34.2	30.9	98	85.7	82.2	79.1	73.5
49	39.4	37.0	35.1	31.7	99	86.7	83.2	80.0	74.4
50	40.3	37.9	35.9	32.5	100	87.6	84.0	80.9	75.3

3.8 Queuing system:

The second Erlang distribution: The queuing system is shown in figure 3.9

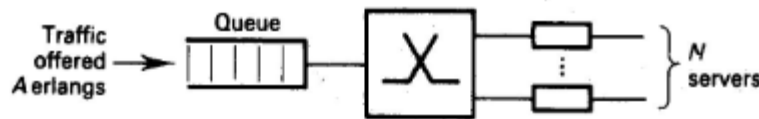

Fig 3.9 Queuing system

Here traffic A is offered to a queuing system with N trunks. Here Erlang determined the probability of encountering delay. Trunks are often called as servers

Erlang solution depends on the following assumptions

- Pure chance traffic
- Statistical equilibrium
- Full availability
- Calls which encounter congestion enter a queue and are stored there until a server becomes free.

It is some time called as M/M/N system

Note: This notation introduced by Kendall

It describes the operating system as X/Y/N Where X is the input process Y is the service time distribution and N is the numbers of servers. The following symbols are used M stands for Markov Process (i.e. random arrivals and terminations).

The pure chance traffic implies that call arrivals and call terminations are independent random events.

The Statistical equilibrium implies that probabilities do not change during the period being considered i.e. $A < N$. If $A \geq N$, calls are entering the system at a greater rate than they leave. As a result, the length of the queue must increase towards infinity. This is not statistical equilibrium.

Let x be the total number of calls in the system. Thus, when $x < N$, then x calls are being served and there is no delay. When $x > N$, all the servers are busy and incoming calls encounter delay; there are N calls being served and $x - N$ calls in the queue.

If $x \leq N$:

There is no queue and the behavior of the system is the same as that of a lost-call system in the absence of congestion. Thus, from equations (1.7)

$$P(x) = \frac{A^x}{x!} P(0)$$

If $x \geq N$: The probability of a call arrival in a very short period of time, δt , from equations (1.2) is given by

$$P(a) = A \delta t / h$$

Where h is the mean service time

Thus the probability of a transition from x-1 to x calls in the system during δt , from equations (1.4) is given by:

$$P(x-1 \rightarrow x) = P(x-1) P(a) = P(x-1) A \delta t/h$$

Since all servers are busy, only the N calls being served can terminate (instead of x calls in a lost- call system). Therefore, modified equation 1.3 is given by

$$P(e) = N \delta t/h$$

And the probability of a transition from x to x-1 calls is given by:

$$P(x \rightarrow x-1) = P(x) P(e) = P(x) N \delta t/h$$

For statistical equilibrium

$$P(x \rightarrow x-1) = P(x-1 \rightarrow x).$$

$$P(x) N \delta t/h = P(x-1) A \delta t/h$$

$$P(x) = \frac{A}{N} P(x-1) \dots \dots \dots 1.10$$

$$\text{But } P(N) = \frac{A^N}{N!} P(0)$$

$$P(N+1) = \frac{A}{N} P(N) = \frac{A^{N+1}}{N.N!} P(0)$$

$$P(N+2) = \frac{A}{N} P(N+1) = \frac{A^{N+2}}{N^2.N!} P(0) \text{ and so on}$$

In general, for $x \geq N$:

$$P(x) = \frac{A^x}{N^{x-N} N!} P(0) = \frac{N^N}{N!} \left(\frac{A}{N}\right)^x P(0) \dots \dots \dots (1.11)$$

If there is no limit to the possible length of Queue, the x can have any value between zero and infinity,

$$\sum_{x=0}^{\infty} P(x) = 1$$

Thus from equations 1.7 and 1.11

$$\frac{1}{P(0)} = \sum_{x=0}^{N-1} \frac{A^x}{x!} + \frac{N^N}{N!} \left(\frac{A}{N}\right)^x \sum_{k=0}^{\infty} \left(\frac{A}{N}\right)^k \dots \dots \dots (1.12)$$

Where $k = x - N$. Since $\frac{A}{N} \leq 1$ then

$$\sum_{k=0}^{\infty} \left(\frac{A}{N}\right)^k = \left[1 - \frac{A}{N}\right]^{-1}$$

$$\frac{1}{P(0)} = \sum_{x=0}^{N-1} \frac{A^x}{x!} + \frac{A^N}{N!} \left[1 - \frac{A}{N}\right]^{-1}$$

$$\frac{1}{P(0)} = \left[\frac{N A^N}{N!(N-A)} + \sum_{x=0}^{N-1} \frac{A^x}{x!} \right] \dots\dots\dots(1.13)$$

Thus, $P(x)$ is given by equations 1.7 or 1.11 depending on whether $x \leq N$ or $x \geq N$

N is given by equation (1.13). This is called as second Erlang distribution

Probability of delay:

Delay occurs if all servers are busy, i.e. $x \geq N$. Now from equation 1.11 the probability that are at least z calls in the system (where $z \geq N$) is given by

$$P(x \geq z) = \sum_{x=z}^{\infty} P(x)$$

$$= \frac{N^N}{N!} P(0) \sum_{x=z}^{\infty} \left(\frac{A}{N}\right)^x$$

$$= \frac{N^N}{N!} P(0) \left(\frac{A}{N}\right)^z \sum_{k=0}^{\infty} \left(\frac{A}{N}\right)^k$$

Where $k = x - N$

$$P(x \geq z) = \frac{N^N}{N!} P(0) \left(\frac{A}{N}\right)^z \left(1 - \frac{A}{N}\right)^{-1} \dots\dots\dots(1.14)$$

$$P(x \geq z) = \frac{N^N}{N!} P(0) \left(\frac{A}{N}\right)^z \frac{N}{N-A}$$

The probability of delay is $P_D = P(x \geq N)$

$$P_D = \frac{A^N}{N!} \frac{N}{N-A} P(0) \dots\dots\dots(1.15)$$

$$P_D = E_{2,N}(A)$$

The probability of delay, for a system with N servers offered traffic A Erlangs, is thus given by equation 1.15 where $P(0)$ is given by equation 1.1. This formula is called as Erlang delay formula.

The probability of delay increases towards 1.0 as an increase towards N . When $A > N$, the length of the queue grows indefinitely, and is shown in figure 1.10.

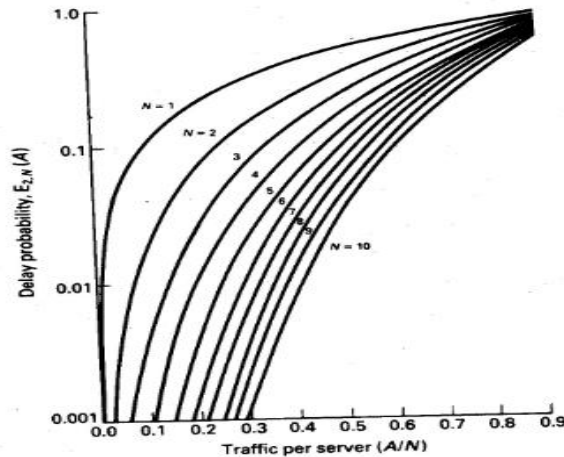

Fig 3.10 Delay probabilities for queuing systems (A= traffic in Erlangs, N=number of servers)

Finite queue capacity:

A practical system cannot contain an infinite queue. Thus, when the queue has become full, calls that arrive subsequently are lost. If the queue can only hold up to Q calls, then $x \leq Q+N$ and equation (1.12) becomes:

$$\frac{1}{P(0)} = \sum_{x=0}^{N-1} \frac{A^x}{x!} + \frac{N^N}{N!} \left(\frac{A}{N}\right)^N \sum_{k=0}^Q \left(\frac{A}{N}\right)^k$$

$$\frac{1}{P(0)} = \sum_{x=0}^{N-1} \frac{A^x}{x!} + \frac{A^N}{N!} \frac{1 - \left(\frac{A}{N}\right)^{Q+1}}{1 - \left(\frac{A}{N}\right)} \text{----- (1.16)}$$

However, if the loss probability is small, there is negligible error in using equation (1.13).

The loss probability can be estimated by first assuming that the queue capacity is infinite and then calculating $P(x \geq Q+N)$

$$P(x \geq Q + N) = \frac{N}{N!} \left(\frac{A}{N}\right)^{Q+N} \frac{N}{N - A} P(0)$$

Now from equation 1.14

$$P(x \geq Q+N) = \left(\frac{A}{N}\right)^Q P_D \text{.....(1.17)}$$

Hence, the queue capacity, Q, needed to obtain an adequately low loss probability can be found

Some other useful results

Equations 1.1 to 1.15 lead to further results,

Follows:

1. Mean number of calls in the system:

- i) When there is delay, the mean number of calls is

$$\bar{x}_1 = \frac{A}{N-A} + N$$

- ii) Averaged over all time, the mean number of calls is

$$\bar{x} = \frac{A}{N-A} E_{2,N}(A) + A$$

2. Mean length of Queue:

- a. When there is delay, the mean queue length is

$$\bar{q}_1 = \bar{x}_1 - N = \frac{A}{N-A}$$

- b. Mean length of queue averaged over all time is

$$\bar{q} = \bar{q}_1 P_D = \frac{A}{N-A} E_{2,N}(A)$$

3. Mean delay time when the queue discipline is first in first out (FIFO):

- i) When there is a delay, mean delay is \bar{T}_1

$$\bar{T}_1 = \frac{h}{N-A}$$

Where h is the mean holding time

- ii) Averaged over all time, the mean delay, \bar{T} , is

$$\begin{aligned} \bar{T} &= E_{2,N}(A) \bar{T}_1 \\ &= E_{2,N}(A) \frac{h}{N-A} \end{aligned}$$

4. Distribution of delays (FIFO queue discipline):

Since the holding times have a negative exponential probability distribution, so since the holding times have a negative exponential probability distribution, so do the delays, T_D . Hence:

- i). When there is delay, $P(T_D \geq t) = e^{-t/\bar{T}_1}$

- ii) Averaged over all time,

$$P(T_D \geq t) = E_{2,N}(A) e^{-t/\bar{T}_1}$$

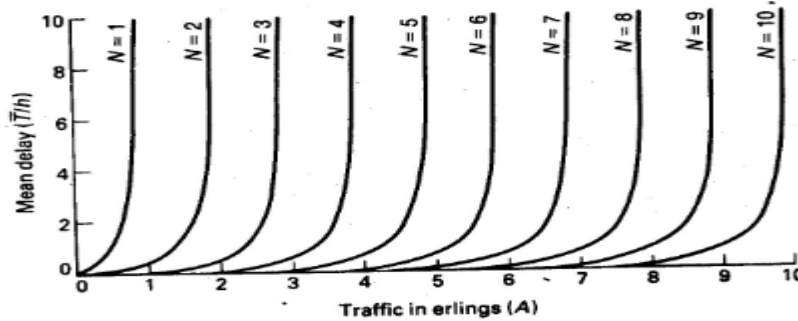

Fig 3.11 Mean delays for queuing systems with FIFO queue discipline (T=mean delay, h=mean service time, N= number of server)

System with single server:

When there is only single server, the probability of it being is simply its occupancy, A and this is the probability of delay i.e. $E_{2,N}(A)=A$. As a result, the expression from previous section yields below results

$$N=1, P_D = E_{2,N}(A) = A$$

$$P_D = \frac{A^N}{N!} \frac{N}{N-A} P(0)$$

$$\text{Then } P(0) = P_D / \left[\frac{A^N}{N!} \frac{N}{N-A} \right] \quad P(0) = A / \left[\frac{A}{1!} \frac{1}{1-A} \right]$$

$$P(0) = 1-A$$

$$\bar{x}1 = \frac{A}{1-A} + 1 = \frac{1}{1-A}$$

$$\bar{x} = \frac{A}{1-A} * A + A = \frac{A}{1-A}$$

$$\bar{q}1 = \bar{x}1 - N = \frac{A}{1-A}$$

$$\bar{q} = \bar{q}1 P_D = \frac{A^2}{1-A}$$

$$\bar{T}1 = \frac{h}{1-A}$$

$$\bar{T} = E_{2,N}(A) \bar{T}1$$

$$= \frac{Ah}{1-A}$$

$$P(x) = \frac{N^N}{N!} \left(\frac{A}{N}\right)^x P(0) A^x (1-A)$$

$$P(x \geq z) = A^z$$

Problem 3.12: A PBX has three operators on duty and receives 400 calls during the busy hour. Incoming calls enter a queue and are dealt with in order of arrival. The average time taken by an operator to handle a call is 18 seconds. Calls arrivals are Poissonian and operator service times have a negative exponential distribution.

1. What percentage of calls have to wait for an operator to answer them?
2. What is the average delay, for calls and for those which encounter delay?
3. What percentage of calls are delayed for more than 30 seconds?

1. $A = 400 * 18 / 3600 = 2.0E$
 From equation (4.13)

$$\frac{1}{P(0)} = \left[\frac{N A^N}{N!(N-A)} + \sum_{x=0}^{N-1} \frac{A^x}{x!} \right]$$

$$\frac{1}{P(0)} = \left[\frac{3 \cdot 2^3}{3!(3-2)} + 1 + \frac{2}{1} + \frac{4}{2} \right] = 4 + 1 + 2 + 2 = 9$$

$$P_0 = 1/9$$

From equation 1.15

$$P_D = \frac{A^N}{N!} \frac{N}{N-A} P(0)$$

$$P_D = \frac{8}{3!} \frac{3}{3-2} \left(\frac{3}{1} + \frac{1}{9} \right) = \frac{4}{9}$$

i.e. 44% of calls have delay on answer

2. When there is delay, the mean delay is:

$$\overline{T_1} = \frac{h}{N-A} = \frac{18}{(3-2)} = 18 \text{ seconds}$$

Where h is the mean holding time

The delay averaged over all time, the mean delay, \overline{T} , is

$$\overline{T} = E_{2,N}(A) \overline{T_1} = 18 * 4/9 = 8 \text{ seconds}$$

When there is delay, $P(T_D \geq t) = e^{-t/\overline{T_1}} = e^{-30/18} = 18.9\%$

Averaged over all time,

$$P(T_D \geq t) = E_{2,N}(A) e^{-t/\overline{T_1}} = 18.9 * 0.44 = 8.3\%$$

Problem 3.13: A message- switching center sends message on an circuit at the rate of 480 characters per second. The average number of characters per message is 24 and the message lengths have a negative exponential distribution. The input of messages is a Poisson process and they are served in order of arrival.

How many messages can be handled per second if the mean delay averaged over all messages) is not exceed 0.5 second?

For a single server the mean delay is

$$\bar{T} = \frac{Ah}{N - A}$$

$$A = \frac{\bar{T}}{h + \bar{T}}$$

Now $h = 24/480 = 0.05$ second

$$A = 0.5 / (0.05 + 0.5) = 0.909 = Ch$$

Where $C =$ number of messages per second

$$C = 0.909 / 0.05 = 18.2$$

Delay tables:

$$\sum_{k=0}^N \frac{A^k}{k!} = \frac{A^N / N!}{E_{1,N}(A)}$$

$$\sum_{k=0}^N \frac{A^k}{k!} = \frac{A^N}{N! E_{1,N}(A)} - \frac{A^N}{N!}$$

Substitute the above equation in $P(0)$

$$\frac{1}{P(0)} = \left[\frac{N A^N}{N!(N-A)} + \sum_{x=0}^{N-1} \frac{A^x}{x!} \right]$$

$$\frac{1}{P(0)} = \left[\frac{N A^N}{N!(N-A)} + \frac{A^N}{N! E_{1,N}(A)} - \frac{A^N}{N!} \right]$$

$$= \frac{A^N N E_{1,N}(A) + (N-A)}{N! (N-A) E_{1,N}(A)}$$

Substituting in equation 1.15

$$P_D = \frac{A^N}{N!} \frac{N}{N-A} P(0) \text{ ----- (1.15)}$$

$$E_{2,N}(A) = \frac{A^N}{N!} \frac{N}{N-A} \frac{N!}{A^N} \frac{(N-A) E_{1,N}(A)}{N E_{1,N}(A) + (N-A)}$$

$$= \frac{N E_{1,N}(A)}{A E_{1,N}(A) + (N-A)}$$

$$= \frac{(N-A) E_{1,N}(A)}{A E_{1,N}(A) + (N-A)}$$

$$E_{2,N}(A) = \frac{N}{(N-A)} E_{1,N}(A)$$

We can calculate the, $E_{2,N}(A)$ from $E_{1,N}(A)$ tables.

Queues in tandem:

Queuing system are connected in tandem the delays are cumulative. If first stage has a Poissonian input and a negative exponential distribution of holding times, The second and subsequent stages are also Poissonian. Thus the operation can be considered as independent for calculating their delays.

The delay probability and the mean delay for the complete system are the sum of these for the individual stages.

However, the probability distribution of such several random variables is obtained by convolution of the separate distributions.

This computation is difficult, so it is usual to specify for each stage the probability of delay exceeding a given value and add these probabilities to obtain a measure of the overall GOS.

This will be pessimistic estimate, because the probability of a long delay at more than one stage should be small.

Applications of delay formulae

Delay formulas are useful in two application areas

In telephone exchange and its switching network → is a circuit switching system (or a lost call system)
In an exchange with registers when all registers are busy, incoming calls are lost

In queuing system Message (switching system or packet switching system). Here if outgoing trunks are busy, messages or packets enter a queue until an outgoing trunk becomes free.

Chapter2:

SWITCHING SYSTEMS: Introduction, Single stage networks, Gradings, Link Systems, GOS of Linked systems.

3.9 Introduction:

In Module2 we learnt the basic prerequisite of this switching system. The basic function of an exchange is making (switching) a connection between calling and called subscriber.

3.10 Classification of Switching Networks

The classification of switching node is based on inlets and outlets,

Single Stage switching Networks

Two Stage switching Networks

Three Stage switching Networks

Four Stage switching Networks

3.11 Single Stage networks:

Single stage switching network having M inlets and N outlets, consisting of a matrix of crosspoints. These may, for example, be separate relays or electronic devices or the contacts of a crossbar switch. The network could also be constructed by multiplying the banks of M uniselectors or one level of a group of M two motion selectors, each having N outlets. In Future system may use photonic switches, in which optoelectronics devices are used as crosspoints to make connections between optical-fiber trunks. The below figure 3.12 shows electromechanical switches, the circle indicates the side of the switch associated with the control mechanism (e.g. the wipers of a strowger switch or the bridge magnet of a crossbar switch).

The matrix of crosspoints switch gives full availability; no calls are lost unless all outgoing trunks are congested. The number of simultaneous connections that can be made is either M (if $M < N$) or N (if $N < M$). The switch contains MN crosspoints.

For $M=N$, total number of crosspoints = $C=N^2$ -----(2.1)

Thus cost (as indicated by the number of crosspoints) increases as the square of the size of the switch. However, efficiency decreases inversely with N .

It is therefore uneconomic to use a single stage network for large numbers of inlets and outlets.

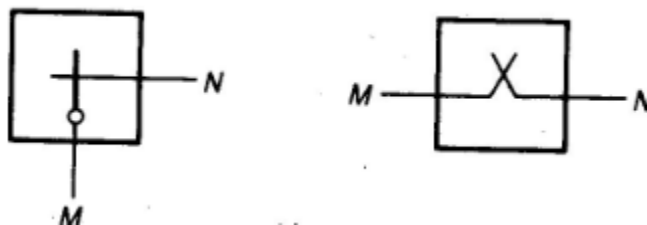

Fig 3.12 switch symbols

For example, a switch with 100 inlets and outlets requires 10,000 crosspoints and only 1% of these can be in use at any time. Switches for making connection between large numbers of trunks are therefore constructed as networks containing several stages of switches.

Matrix of cross point switches issued to make connection between N similar circuits, then each circuit is connected to both an inlet and an outlet. Operation of the crosspoints at coordinates (j, k) to connect inlet j to outlet k thus performs the same function as operating crosspoints (k, j) to outlet j. Consequently, half the crosspoints are redundant and can be eliminated. This results in the triangular crosspoints matrix shown in figure 3.13 The number of crosspoints of required is

$$C_1 = \frac{1}{2} N(N-1) \dots\dots (2.2)$$

These are used in providing ringing tone and ringing current are sent over separate one way trunks depending on the customer's line is calling or being called.

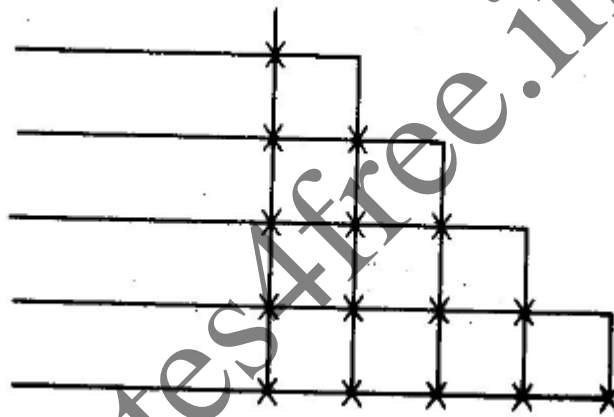

Fig 3.13 triangular cross point matrix for connecting both way trunks

3.12: Gradings

The number of outgoing trunks connected to incoming trunks is known as availability.

3.12.1: Principle:

For a route switch or a concentrator it is not necessary for each incoming trunk to have access to every outgoing trunk. It is adequate if each incoming trunk has access to a sufficient number of trunks on each route to give the required grade of service. This is known as limited availability. The number of outgoing trunks to which an incoming trunk can obtain connection is called the availability and corresponds to the outlet capacity of the switches used.

Figure 3.14(a) shows 20 trunks on an outgoing route to which incoming trunks have access by means of switches giving an availability of only ten.

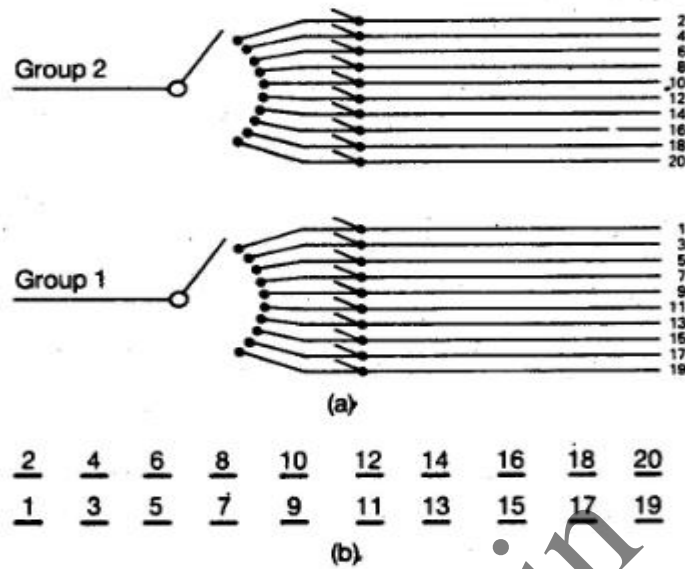

Figure 3.14 Twenty trunks connected in two separate groups to switches of availability 10 (a) Full diagram (b) Grading diagram

In Figure 3.14(a), the outlets of the switches are multiplied together in two separate groups and ten outgoing trunks are allocated to each group.

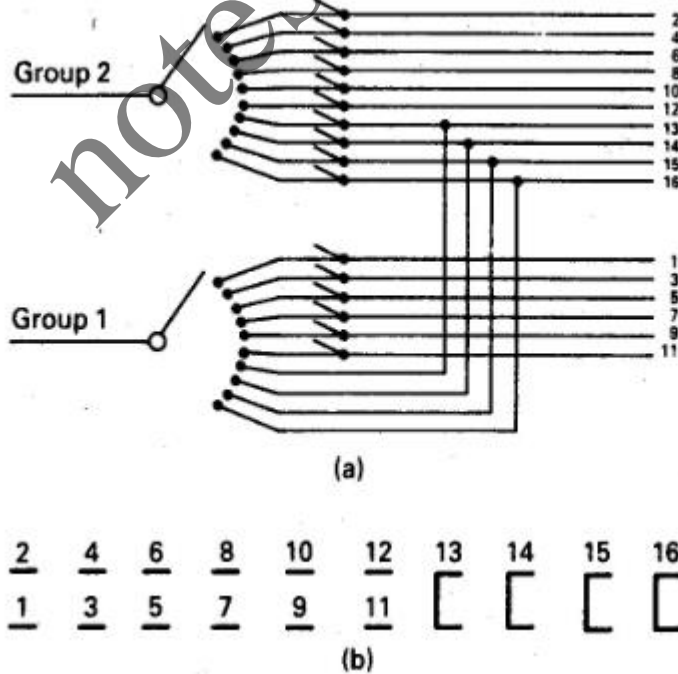

Figure 3.15 Sixteen trunks interconnected to two groups of switches of availability 10. (a) Full diagram. (b) Grading diagram.

If the traffic offered to the two groups of incoming trunks is random, peak loads will seldom occur simultaneously in the two groups. Efficiency can therefore be improved through mixing the traffic by interconnecting the multiples of the two groups so that some of the outgoing trunks are available to both groups of switches.

If the switches search sequentially for free outlets, the later-choice outlets carry the least traffic. It is therefore desirable to connect the later-choice trunks to both groups of selectors, as shown in Figure 3.15(a) and grading diagram shown in figure 3.15(b).

In this arrangement, the first six outlets are in two separate full-availability groups; the last four outlets are common to both groups and carry the traffic that overflows when the first six outlets of either group are busy.

Design of progressive gradings

In order to form a grading, the switches having access to the outgoing route are multiplied into a number of separate groups, known as *graded groups*.

On early choices each group has access to individual trunks and on late choices trunks are common, as shown in Figure 3.15. This diagram shows a small grading for only two groups -of switches. For larger numbers of outgoing trunks, gradings may contain four or more groups.

Figure 2.5 shows four-group gradings. Since the traffic decreases with later choices of outlet, the number of groups connected together increases from individual connections on the early choices through partial commons (doubles) to full commons on the late choices.

Switches hunt over the outlets sequentially from a home position.

In designing a grading to provide access to N outgoing trunks from switches having availability k , the first step is to decide on the number of graded groups g .

If all the choices were individual trunks, we would have

$$N = gk .$$

If all the choices were full commons,

$$N = k .$$

Since the grading contains a mixture of individuals, partial commons and full commons, then $k < N < gk$.

A reasonable choice for N is $N = \frac{1}{2}gk$ and traffic simulations have shown that the efficiency of such gradings is near the optimum.

The number of groups is thus chosen to be: $N = \frac{1}{2}gk$

$$2N = gk$$

$$g = \frac{2N}{k} \text{ -----(2.3)}$$

Since the grading should be symmetrical, g must be an even number, so the value of g given by equation (2.3) is rounded up to the next even integer.

It is now necessary to decide how the g_k trunks entering the grading are to be interconnected to N outgoing trunks.

For a two-group grading there is only one solution. If the number of columns of 'singles' is s and the number of commons is c , then:

$$\text{Availability} = k = s + c$$

$$\text{No. of trunks} = N = 2s + c$$

$$s = N - k \text{ and } c = 2k - N$$

If the grading has more than two groups, there is no unique solution. It is necessary to choose from the possible solutions the best one, i.e. the grading with the greatest traffic capacity.

- The traffic offered to adjacent outlets will not differ greatly, so they should not be connected to very different sizes of common.
- There should thus be a smooth progression on the choices from individuals to partial commons, from smaller partial commons to larger ones, and from partial commons to full commons.
- The numbers of choices of each type in a group should therefore be as nearly equal as possible.
- This is achieved by minimizing the sum of the successive differences between the number of choices of one type and those of the type following it.

Let g have q factors: $f_1 < f_2 < \dots < f_i \dots < f_q$. Where

$$f_1 = 1 \text{ and } f_q = g$$

Let r_i be the number of choices having their incoming trunks connected as f_i tuples

$$\sum_{i=1}^q r_i = k \dots \dots \dots (2.4)$$

Now each f_i tuple contains g/f_i outgoing trunks.

$$\sum_{i=1}^q \frac{r_i g}{f_i} = k \dots \dots \dots (2.5)$$

Since there are only two equations and more than two unknowns (if $q > 2$), there are a number of different solutions for (r_1, \dots, r_q) . These are round and, for each, the sum of the successive differences, D , is given by :

$$D = |r_1 - r_2| + |r_2 - r_3| + \dots + |r_{q-1} - r_q| \dots (2.6)$$

The best grading is that having the smallest value of D .

Design of Progressive grading:

This is the most commonly used to grading methods

Step1: Find out the number of groups

$$g = 2N/k$$

Step2: Find out the number of single, doubles and quadruples

Step3: Write simultaneous equations

Step4: single, doubles and quadruples tabulate the results

Sl. No	Single	doubles	Quadruples	Sum of successive difference
1.				
2.				
3.				

Note: The Scheme which gives the maximum successive difference is the best grading.

Problem 3.14

Design a grading for connecting 20 trunks to switches having ten outlets.

Solution:

The number of graded groups, given by equation (2.3) is

$g = 2 * N / k = 40 / 10 = 4$, and the factors of g are 1, 2 and 4.

Let the number of choices having singles = s

the number of choices having doubles = d

the number of choices having quadruples = q

substituting in equations (2.4)

$$\sum_{i=1}^q r_i = k$$

$$s + d + q = 10 \text{ -----(1)}$$

$$4s + 2d + q = 20 \text{ -----(2)}$$

From (2) - (1) = $3s + d = 10$

Substituting in equations (2.5)

$$\sum_{i=1}^q \frac{r_i g}{f_i} = k$$

$s = 1: d = 7$ and $q = 10 - 8 = 2$

$s = 2: d = 4$ and $q = 10 - 6 = 4$

$s = 3: d = 1$ and $q = 10 - 4 = 6$

$s = 4: d < 0$, so this is not possible.

There are thus three possible gradings, which are shown in Figure 3.16. The sums of the successive differences for these gradings are respectively given by:

$$D = |r_1 - r_2| + |r_2 - r_3| + \dots + |r_{q-1} - r_q|$$

Case1) $D_1 = |7-1| + |2-7| \quad D_1 = 6 + 5 = 11$

$D_2 = |4-2| + |4-4| = 2 + 0 = 2$

$D_3 = |1-3| + |6-1| = 2 + 5 = 7$

The second grading (shown in Figure 5.5(b)) is therefore the best.

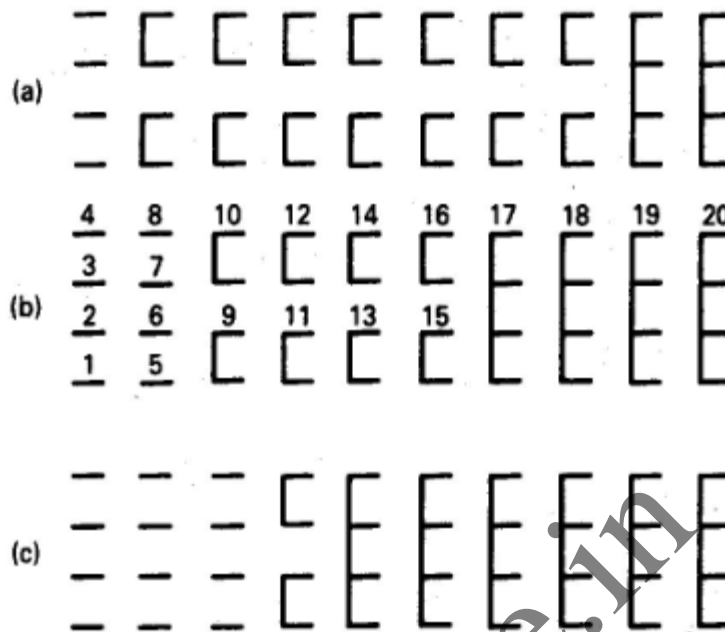

Figure 3.16 Four group grading for 20 trunks (availability 10)

If a growth in traffic makes it necessary to increase the number of trunks connected to a grading, this can be done by reducing the number of commons and partial commons and increasing the number of individuals. Figure 3.17 shows the grading of Figure 2.5(b) rearranged to provide access to 25 trunks.

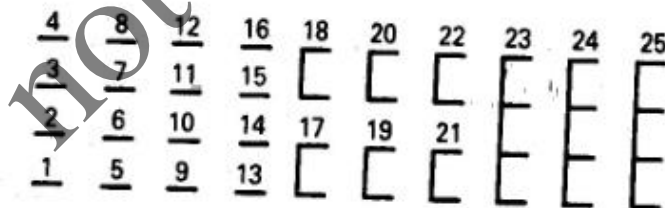

Figure 3.17 a). Grading of Figure 3.16 (b) modified to accommodate 25 trunks.

Problem 3.15:

Find the best formation for a 6 group grading for 32 trunks with availability of 10.

The number of graded groups, given by equation (2.3) is

$$g = 2*N/k = 2*32/10 = 6.4 = 6, \text{ and the factors of } g \text{ are } 1, 2, 3, 6.$$

Let the number of choices having singles = s
 the number of choices having doubles = d
 the number of choices having triples = t
 the number of choices having six lines (full commons) = fc

Note: $s, d, t,$ or fc can never exceed 10

$$s + d + t + fc = 10 \text{ availability -----(1)}$$

$$6s + 3d + 2t + fc = 32 \text{ trunks -----(2)}$$

From (2) - (1) = $5s + 2d + t = 22$

Note: s, d, t, fc can never exceed 10.

S cannot be more than 4.

Successive difference is calculated by

$$*D = |r_1 - r_2| + |r_2 - r_3| + \dots + |r_{q-1} - r_q|$$

$$5s + 2d + t = 22$$

When

$S = 4, 2d + t = 2, d$ cannot be > 1 hence $d = 1$ and $t = 1$

$S = 3, 2d + t = 7, d$ cannot be > 3

$S = 2, 2d + t = 10, d$ cannot be > 5

$S = 1, 2d + t = 17, d$ cannot be > 8

$S = 0, 2d + t = 22, d$ cannot be > 10

SL.No	No. of singles S	No. of double lines d $2d+t=7$	No. of triple line (t) $5s+2d+t=22$	No. of 6 lines or full commons (fc) $S+d+t+fc=10$	Successive difference is calculated *
Case 1	4	0	2	4	$4+2+2=8$
Case 2	4	1	0	5	$3+1+5=9$
Case 3	3	3	1	3	$0+2+2=4$
Case 4	3	1	3	2	$2+2+1=5$
Case 5	3	1	5	1	$2+4+4=10$

Case 6	3	0	7	0	$3+7+7=17$
Case 7	S=2	5	2	1	$3+3+1=7$
Case 8	S=2	D=4	T=4	Fc=0	$ 2-4 + 4-4 + 0-4 =$ $2+0+4=6$
Case 9	S=2	D=3	T=6	Fc= -1 (invalid)	
Case 10	2	2	8	-2 (invalid)	
Case 11	2	1	10	-3(invalid)	
Case 12	2	0	12	-4(invalid)	
Case 13	1	8	1	0	$7+7+1=15$
Case 14	S=1	d=7	T=15	Fc= -7 once invalid don't consider that. (invalid)	
Case 15	S=1	D=6	T=11	c= -4 (invalid)	
Case 16	1	5	7	Fc= -4 (invalid)	
Case 17	1	4	9	Fc= -4 (invalid)	
Case 18	1	3	11	Fc= -4 (invalid)	
Case 19	1	2	13	Fc= -4 (invalid)	
Case 20	1	1	15	Fc= -4 (invalid)	
Case 21	1	0	17	Fc= -4 (invalid)	

There is one case where in successive difference is minimum. i.e., 4

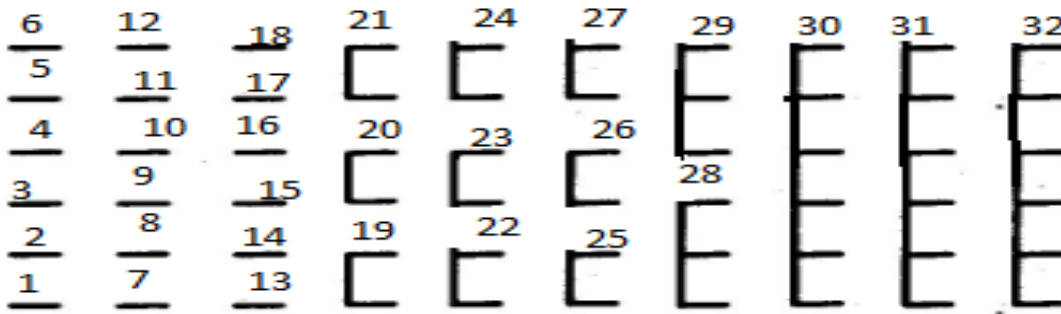

Figure 3.17b) Grading diagram for minimum successive difference

Where in $s=3$ $d=3$ and $t=1$ and $fc=3$

3.12.2 Other form of Grading

Skipped Grading

In an O'Dell grading, the partial commons are arranged as separate groups, so each is available to only some of the incoming trunks.

For example, in Figure 3.16(b) the upper of pairs serves only the first two groups. However, the principle of grading is based on the sharing of outgoing trunks between different sets of incoming trunks. Efficiency can be improved if this principle can be applied to the whole of a grading instead of only to parts of it.

This can be done by connecting non-adjacent groups, in addition to adjacent groups, as shown in Figure 3.18. This is known as skipping.

In this grading in addition to communing adjacent groups, non-adjacent groups also are commonly connected. This avoids upper half and lower half of the group to be separated. Traffic is evenly distributed in both the halves.



Figure 3.18a Skipped grading

Homogeneous Grading

Progressive gradings are intended to be used with switches that hunt sequentially from a fixed home position. However if switches do not hunt from a single position, or they select outlets at random, there is no advantage in connecting some outlets to singles and others to

partial or full commons. The grading should then be designed to share each trunk between an equal numbers of groups, as shown in figure 3.18b. this is known as Homogeneous Grading.



Figure 3.18b Homogeneous grading.

Traffic capacity of grading

In an ideal grading, the interconnections would ensure that each outgoing trunk carried an identical traffic load.

Thus, if total traffic A is carried by N trunks, the occupancy of each trunk is A/N .

It is assumed that each trunk being busy is an independent random event.

Each call has access k to trunks (where k is the availability), and the probability of all k trunks being busy is thus:

$$B = (A/N)^k$$

The number of trunks required to carry A Erlangs with a GOS of B is therefore given by:

$$N = (AB)^{1/k} \quad (2.7)$$

This is *Erlang's ideal grading formula* and gives a linear relationship between the traffic and the number of trunks required.

Practical gradings do not satisfy the conditions for Erlang's ideal grading.

However, they satisfy a linear relationship between traffic capacity A and number of trunks for a given grade of service B .

Figure 3.19

An approximate curve of A against N can therefore be derived from Erlang's full-availability theory for $N < k$ and extended as a straight line for $N \geq k$.

From equation (2.7) this line is given by:

$$A = A_k + (N - k) B^{1/k}$$

Where A_k is the traffic carried by a full-availability group of k trunks (with GOS = B). Figure 3.19 shows a family of curves plotted from the above modified Erlang formula.

Problem 3.16: Find the traffic capacity of the two-group grading shown in Figure 3.15 if the required grade of service is 0.01.

For $k = 10$ and, from Table 4.1, $A_k = 4.5$ E.

From equation (5.8):

$$\begin{aligned} A &= A_k + (N - k) B^{1/k} \\ &= 4.5 + (16 - 10) \times 0.01^{0.1} \\ &= 4.5 + 6 \times 0.631 \\ &= 8.3 \text{ E} \end{aligned}$$

(Given in table 4.1 that a full-availability group of 16 trunks can handle 8.9 E with 0.01 grade of service.)

3.12.3 Application of Grading:

Gradings have been widely employed in step-by-step systems.

In trunk distribution frames (TDF) between the ranks of selectors provide cross-connections in the form of gradings. Another example of the use of a grading in a link system is in the Bell No.1 ESS system.

The subscribers' concentrator of this system is shown in Figure 3.21 (a). The number of crosspoints required in the primary switches is reduced by omitting them in a systematic manner.

Each primary switch is equivalent to four groups of four-outlet selectors having access to eight trunks through the homogeneous grading shown in Figure 3.20(b).

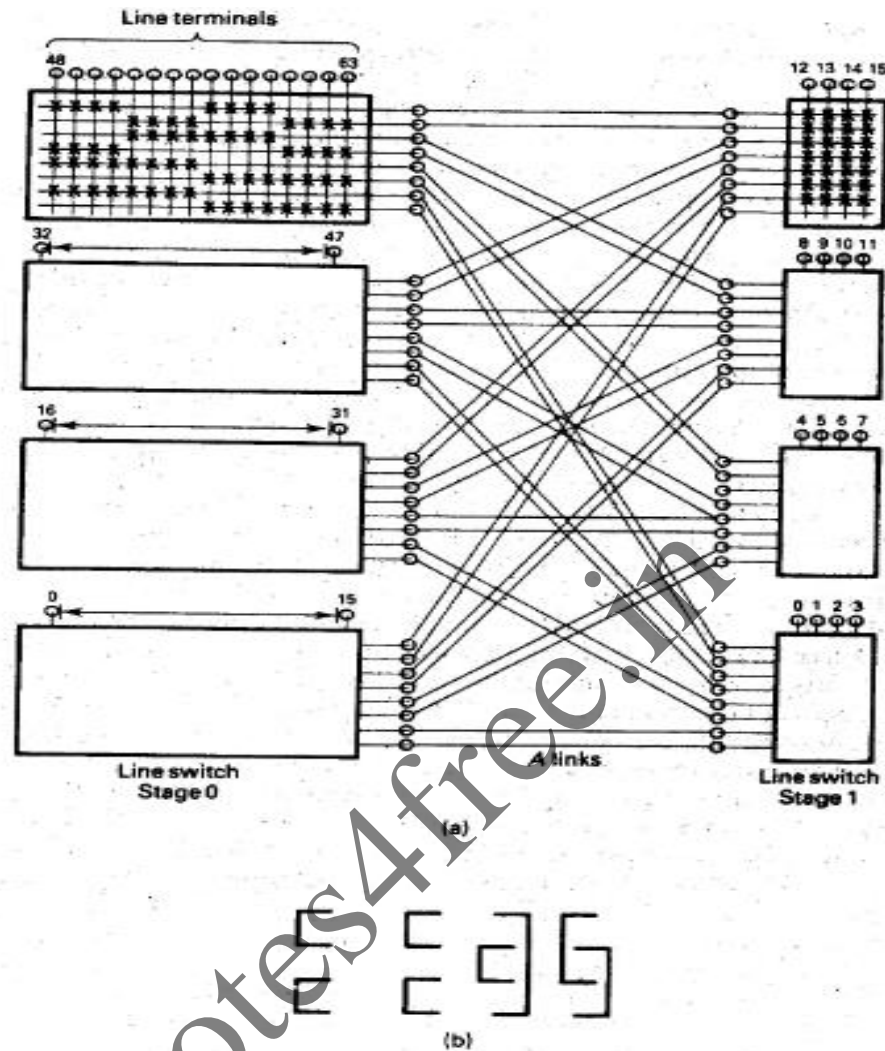

Figure 3.20 Two stage concentrator used in Bell No.1 ESS system. a) Arrangement of trunks, b). Four group homogeneous grading incorporated at stage [AT & T lab copy right document]

3.13: Link Systems

General

Two stage Switching network:

In the two-stage network (of previous chapter) there is only one link between each primary switch and each secondary switch. Thus, it may be impossible to make a connection from a given incoming trunk to a selected outgoing trunk because the link is already being used for another connection between that primary switch and that secondary switch. This situation is called *blocking*.

It is also known as a *mismatch*, because free links exist but none of them can be used for the required connection.

If connection must be made to one particular outgoing trunk the probability of blocking is unacceptably high. For this application, it is therefore necessary to use a network with more stages e.g. the four-stage network in order to have a choice of paths through the network.

The two-stage network of Figure 3.21 can be used as a route switch. If it serves ten outgoing routes with ten trunk on each route, then trunk no.1 of each route is connected to secondary switch no. 1, trunk no. 2 is connected to switch no.2, and soon.

Thus, an incoming trunk can obtain connection to the selected outgoing route via any of the links outgoing from its primary switch. The call is only lost if all the paths to free outgoing trunks are blocked.

The probability of this occurring simultaneously for links is obviously much smaller than the probability of a single link being busy. Similarly, if the incoming trunks are from several different routes, one trunk from each route is normally terminated on each primary switch.

Step-by-step selection is unsuitable. This is because calls are lost by internal blocking in addition to congestion of the external trunks.

It has been seen that the grade of service of a link system depends on the way it is used. We may classify these uses as follows:

Mode 1: Connection is required to one particular free outgoing trunk. (Since conditional selection is used, an attempt will not be made to set up this connection unless the trunk is free.)

Mode 2: Connection is required to a particular outgoing route, but any free trunk on that route may be used.

Mode 3: Connection may be made to any free outgoing trunk.

It will be seen from Figure 3.21 that a concentrator operates in mode 3, a route switch operates in mode 2 and an expander operates in mode 1.

Two-stage networks

If the two-stage network shown in Figure 3.21 has N incoming and N outgoing trunks and contains primary switches having n inlets and secondary switches having n outlets.

Then no. of primary switches (g) = no. of secondary switches = no. of outlets per primary switch = no. of inlets per secondary switch,

where

$$g = N/n \dots\dots(1)$$

The number of crosspoints per primary switch = number of crosspoints per secondary switch = $gn = N \dots\dots(2)$

The total number of crosspoints (C_2) in the network = (number of switches) x (crosspoints per switch) i.e. $C_2 = gN + gN$ from equation 1 in 2.9

$$C_2 = 2gN = 2 * N/n * N = 2N^2/n \quad \text{---(2.9)}$$

Since there is one link from each primary switch to each secondary switch, the number of links is equal to no. of primary switches x no. of secondary switches, i.e

$$\text{No. of links} = g^2 = (N/n)^2 \quad \text{(2.10)}$$

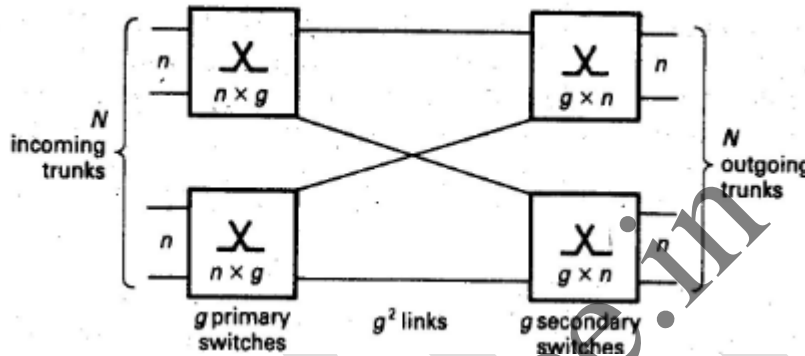

Figure 3.21 Two stage switching network

The number of crosspoints thus varies as $1/n$, but the numbers of link varies as $1/n^2$. If n is made very large to reduce the number of crosspoints, there will be too few links to carry the traffic. Let the number of links be equal to the number of incoming and outgoing trunks, a reasonable choice, since each set of trunks carries the same total traffic.

Then $g^2 = N \dots \dots \dots (*)$

Substituting (*) in equation (2.10) gives $N = (N/n)^2$

$$N = n^2$$

$$n = \sqrt{N} \quad \dots \dots (2.11)$$

Then the total number of crosspoints (from equation (2.9)) is

$$C_2 = 2N^{3/2} \quad \dots \dots \dots (2.12)$$

Equation (2.11) can be only a guide; one should select the nearest integer to n that is a factor of N .

Also, in practice, designers are often constrained to use switch units of fixed sizes. For example, crossbar switches may be of sizes 10 x 10 or 10 x 20.

The Bell No. 1 ESS system uses switches constructed from modules of size 8 x 8 and the British Telecom TXE2 system uses modules of size 5 x 5.

The number of crosspoints per incoming trunk (from equation (2.12)) is $2N^{1/2}$

The cost per trunk therefore increases fairly slowly with the number of trunks. For large networks, however, it becomes more economic to use networks with more than two stages.

Incoming Trunks not equal to Outgoing trunks ($M \neq N$)

Consider a concentrator with M incoming trunks and N outgoing trunks ($M > N$).

Let each primary switch have m inlets and each secondary switch have n outlets. Then

$$\text{No. of primary switches} = M/m = g \quad (1)$$

$$\text{No. of secondary switches} = N/n = g \quad (2)$$

$$\text{No. of crosspoints per primary switch} = m \times N/n \quad (3)$$

$$\text{No. of crosspoints per secondary switch} = n \times M/m. \quad (4)$$

The total number of crosspoints is:

The number of links = number of primary switches \times number of secondary switches

$$C_2 = g \times \frac{mN}{n} + g \times \frac{nM}{m}$$

$$C_2 = \frac{M m N}{m n} + \frac{N n M}{n m}$$

$$C_2 = MN \left[\frac{1}{n} + \frac{1}{m} \right] \quad (5)$$

The number of links = number of primary switches \times number of secondary switches

$$g^2 = \frac{MN}{mn}$$

Since the traffic capacity is limited by the number of outgoing trunks, there is little point in providing more than this number of links, so let the number of links be N .

$$\frac{MN}{mn} = N$$

And

$$M = mn$$

$$n = M/m \dots \dots (6)$$

Substituting equation (6) in equation (5)

$$C_2 = MN \left[\frac{m}{M} + \frac{1}{m} \right] \quad (7)$$

In order to minimize C_2 treat m as if it were a continuous variable and differentiate with respect to it

$$\begin{aligned}\frac{dC_2}{dm} &= MN \left[\frac{1}{M} - \frac{1}{m^2} \right] \\ &= 0 \text{ when } m = \sqrt{M} \quad (8)\end{aligned}$$

$$m=n = \sqrt{M}$$

Hence, from equation (8) in equation (6):

$$m=n = \sqrt{M}$$

Thus, the number of crosspoints is a minimum when the number of inlets per primary switch equals the number of outlets per secondary switch.

Substituting in equation (2.13)

$$\begin{aligned}C_2 &= MN \left[\frac{1}{\sqrt{M}} + \frac{1}{\sqrt{M}} \right] \\ &= MN \left[\frac{2}{\sqrt{M}} \right] \\ &= 2 \frac{M}{\sqrt{M}} N \\ &= 2M^{\frac{1}{2}} N\end{aligned}$$

Incoming Trunks not equal to Outgoing trunks ($M \neq N$)

Consider a concentrator with M incoming trunks and N outgoing trunks ($M < N$).

Let each primary switch have m inlets and each secondary switch have n outlets. Then

$$\text{No. of primary switches} = M/m = g \quad (1)$$

$$\text{No. of secondary switches} = N/n = g \quad (2)$$

$$\text{No. of crosspoints per primary switch} = m \times N/n \quad (3)$$

$$\text{No. of crosspoints per secondary switch} = n \times M/m. \quad (4)$$

The total number of crosspoints is:

The number of links = number of primary switches \times number of secondary switches = C_2

$$C_2 = g \times \frac{mN}{n} + g \times \frac{nM}{m}$$

$$C_2 = \frac{M m N}{m n} + \frac{N n M}{n m}$$

$$C_2 = MN \left[\frac{1}{n} + \frac{1}{m} \right] \quad (5)$$

The number of links = number of primary switches \times number of secondary switches

$$g^2 = \frac{MN}{mn}$$

Since the traffic capacity is limited by the number of outgoing trunks, there is little point in providing more than this number of links, so let the number of links be N .

$$\frac{MN}{mn} = M$$

And

$$N = mn$$

$$m = N/n \dots (6)$$

Substituting equation (6) in equation (5)

$$C_2 = MN \left[\frac{n}{N} + \frac{1}{n} \right] \quad (7)$$

In order to minimize C_2 treat n as if it were a continuous variable and differentiate with respect to it

$$\frac{dC_2}{dn} = MN \left[\frac{1}{N} - \frac{1}{n^2} \right]$$

$$MN \left[\frac{1}{N} - \frac{1}{n^2} \right] = 0$$

$$\begin{aligned} n^2 &= N \Rightarrow n = \sqrt{N} = m \\ &= 0 \text{ when } m = \sqrt{N} \quad (8) \end{aligned}$$

$$m = n = \sqrt{M}$$

Hence, from equation (8) in equation (6):

$$m = n = \sqrt{M}$$

Thus, the number of crosspoints is a minimum when the number of inlets per primary switch equals the number of outlets per secondary switch.

Substituting in equation (2.13)

$$\begin{aligned} C_2 &= MN \left[\frac{1}{\sqrt{N}} + \frac{1}{\sqrt{N}} \right] \\ &= MN \left[\frac{2}{\sqrt{N}} \right] \\ &= 2 \frac{M}{\sqrt{N}} N \\ &= 2N^{\frac{1}{2}} M \end{aligned}$$

Problem 3.17

Design a two-stage switching network for connecting 200 incoming trunks to 200 outgoing trunks.

Now, $\sqrt{200} = 14.14$.

However, n must be a factor of 200, so the nearest practicable values are $n = 10$ and $n = 20$.

Two possible networks are shown in Figure 2.12.

$$\begin{aligned}
 \text{No of Crosspoints} &= 2N^{3/2} \\
 &= 2 \times (200)^{3/2} \\
 &= 2 \times 2.828 \times 10^3 \\
 &= 5656 \text{ crosspoints} \\
 &= \text{almost it contains } 6000 \text{ crosspoints.}
 \end{aligned}$$

The network of Figure 3.22(a) is suitable for 20 outgoing routes, each having 10 trunks, and that of Figure 3.22(b) is suitable for 10 outgoing routes, each having 20 trunks.

The network in Figure 3.21 has the same number of outgoing trunks as incoming trunks. However, a concentrator has more incoming than outgoing trunks and an expander has more outgoing than incoming trunks

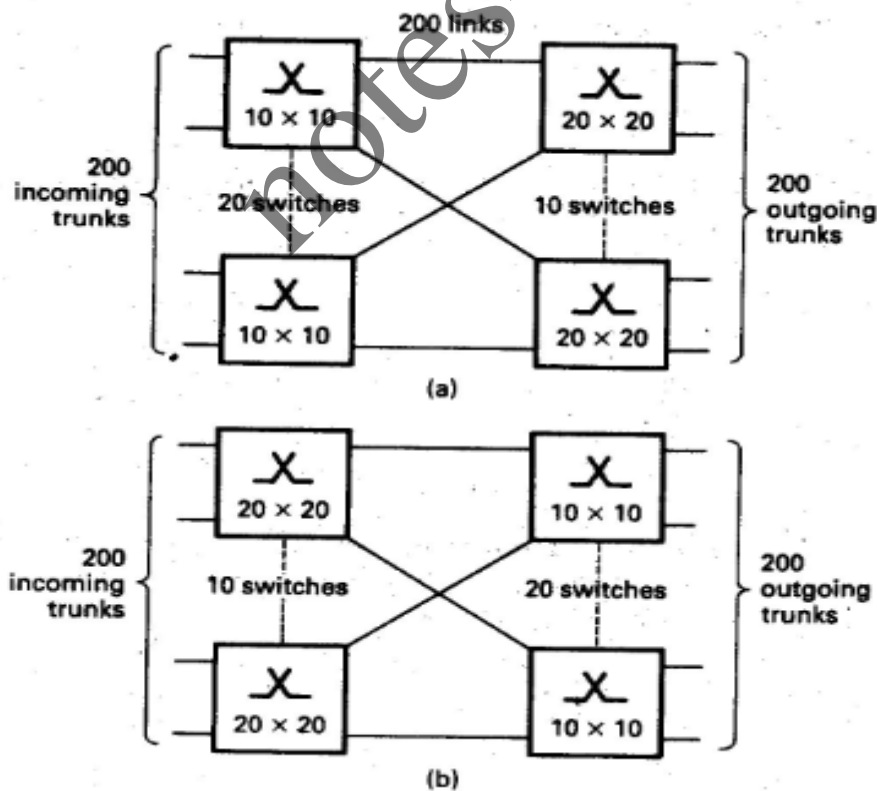

Figure 3.22 Examples of two-stage networks. (a) For 20 outgoing routes (10 trunks on each).
(b) For 10 outgoing routes (20 trunks on each).

Problem 3.18

Design a two stage network to connect 12 incoming trunks to 9 outgoing trunks and arrive at the optimum solution

Solution:

Incoming trunks $M = 12$

Outgoing trunks $N = 9$

If $M > N$ Hence this is a concentrator

For minimum crosspoints

$$\text{As } m = n = \sqrt{M} = \sqrt{12} = 3.47$$

But m and n should be integer and factors of 12. Hence two cases are possible

$$\text{As } m = n = 3$$

$$\text{As } n = m = 4$$

When $m = n = 3$

$$C_2 = MN \left[\frac{m}{M} + \frac{1}{m} \right]$$

$$C_2 = 12 * 9 \left[\frac{3}{12} + \frac{1}{3} \right]$$

$$= 63$$

When $m = n = 4$

$$C_2 = MN \left[\frac{m}{M} + \frac{1}{m} \right]$$

$$C_2 = 12 * 9 \left[\frac{4}{12} + \frac{1}{4} \right]$$

$$= 63$$

Practical use

$$\text{As } n = \sqrt{N} = \sqrt{9} = 3$$

$$m = \frac{M}{\sqrt{n}} = \frac{12}{\sqrt{9}} = \frac{12}{3} = 4$$

$$C_2 = MN \left[\frac{m}{M} + \frac{1}{m} \right]$$

$$C_2 = 12 * 9 \left[\frac{4}{12} + \frac{1}{4} \right]$$

$$= 63$$

Any of the above design can be used.

Three Stage Networks:

In the three stage networks of figure 3.23 there are

N incoming and N outgoing trunks has primary switches with n inlets and tertiary switches with n outlets,

then

No. of primary switches (g_1) = No. of tertiary switches (g_3) = N/n .

The secondary switches have N/n inlets and outlets.

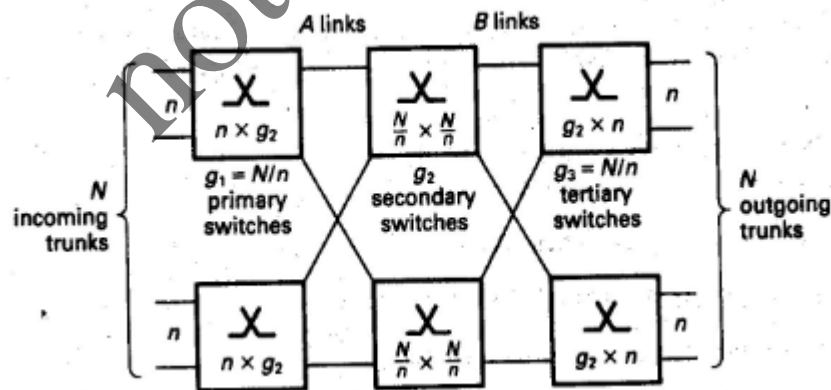

Figure 3.23 Fully interconnected three stage switching network

Let there be N number of primary-secondary links (A links) and N Number of secondary-tertiary links (B are each N)

then the number of secondary switches is

$$g_2 = N \div (N/n)$$

= no. of outlets per primary switch = no. of inlets per tertiary switch

$$\text{No. of crosspoints in primary stage} = n^2(N/n) = nN$$

$$\text{No. of crosspoints in secondary stage} = n(N/n)^2 = N^2/n$$

$$\text{No. of crosspoints in tertiary stage} = n^2(N/n) - nN$$

and the total number of crosspoints is

$$= nN + \frac{N^2}{n} + nN$$

$$= 2nN + \frac{N^2}{n}$$

$$C_3 = N \left(2n + \frac{N}{n} \right)$$

By differentiating equation (2.17) with respect to n and equating to zero, it can be shown that the number of crosspoints is a minimum when

$$n = \sqrt{N/2}$$

$$\text{And then } C_3 = 2\sqrt{2}N^{3/2}$$

$$= \sqrt{2} C_2$$

$$= 2^{3/2} N^{-1/2} C_1$$

Design for $M > N$

If a three-stage concentrator has M incoming trunks and N outgoing trunks ($M > N$), its primary switches each have m inlets and its tertiary switches each have n outlets. Then

$$\text{No. of primary switches} = M/m$$

$$\text{No. of tertiary switches} = N/n$$

If there are g_2 secondary switches, then

$$\text{Crosspoints per primary switch} = m g_2$$

$$\text{Crosspoints per secondary switches} = \frac{M N}{m n}$$

$$\text{Crosspoints per tertiary switch} = g_2 n$$

The total number of crosspoints is

$$C_3 = \frac{M}{n} X m g_2 + g_2 X \frac{M N}{m n} + \frac{N}{n} X g_2 n$$

$$= g_2 \left[M + N + \frac{M N}{m n} \right]$$

Since $M > N$, let no. of A links = no. of B links = N .

$$= g_2 \frac{M}{m} = g_2 \frac{N}{n}$$

Hence, $g_2 = n$ and $m = n M/N$.

Substituting in equation (2.20):

$$C_3 = (M + N) n + N^2/n$$

Differentiating with respect to n to find a minimum gives:

$$\text{I.e. } m = \frac{M}{\sqrt{M+N}} \quad n = \frac{N}{\sqrt{M+N}}$$

$$C_3 = 2N \sqrt{N + M}$$

To obtain an expander, M is exchanged with N and m with n .

Problem 3.19

Design a three-stage network for connecting 100 incoming trunks to 100 outgoing trunks:

$$\sqrt{\frac{100}{2}} = 7.07 \text{ use } n = 5 \text{ or } n = 10$$

- If $n = 5$, there are:
 - 20 primary switches of size 5×5
 - 5 secondary switches of size 20×20
 - 20 tertiary switches of size 5×5
- If $n = 10$, there are 10 primary switches, 10 secondary switches and 10 tertiary switches, each of size 10×10

$$\text{No. of crosspoints} = C_3 = 2\sqrt{2}N^{3/2}$$

$$C_3 = 2\sqrt{2}100^{3/2}$$

$$= 2828 \text{ cross points}$$

= 3000 Cross points

Problem 3.20

Design a three-stage network for 100 incoming trunks and 400 outgoing trunks.

$$\frac{100}{\sqrt{100 + 400}}$$

$$= 4.47$$

$$\frac{400}{\sqrt{100+400}} = 11.89$$

1. $m = 4$ or 5 ; $n = 16$ or 20

If $m = 5, n = 20$, there are:

20 primary switches of size 5×5

5 secondary switches of size 20×20

20 tertiary switches of size 5×20

2. If $m = 4, n = 16$, there are:

25 primary switches of size 4×4

4 secondary switches of size 25×25

25 tertiary switches of size 4×16 .

$$C_3 = 2N \sqrt{N + M}$$

$$= 2 \times \sqrt{100 + 400}$$

$$= 200 \times 22.3$$

$$= 4460$$

Say = 4500

Both networks contain 4500 crosspoints.

However, the first contains more secondary switches and will therefore cause less blocking.

In a three-stage network, the number of the selected outgoing trunk is given by outlet numbers used on the secondary and tertiary switches.

It is not related to the outlet used in the primary switch, since any secondary switch may be used for connection to a given outgoing trunk.

For each connection, two sets of links must be interrogated for the busy/free condition and matched to choose a pair connected to the same secondary switch.

The control of a three-stage network is thus more complex than that of a two-stage one.

For this reason, electromechanical systems usually use trunkings containing a number of separate two-stage networks in tandem. However systems having electronic central control often employ three-stage switching networks.

A fully interconnected three-stage network (as shown in Figure 3.23) requires a large number of crosspoints when N is large. A reduction can be made in the number of crosspoints (at the expense of an increase in blocking) if the secondary switches have links to only some of the primary and tertiary switches, as shown in Figure 3.24.

The secondary and tertiary switches are arranged in separate groups (frames) and are fully interconnected only within their groups. Each primary switch has one link to each of these secondary-tertiary groups. (Alternatively, the primary and secondary switches may be arranged in separate groups, to produce the mirror image of Figure 3.24.)

The number of switches is $3n^2$ and each has n^2 crosspoints, so the total number of crosspoints is:

$$C_3 = 3n^4 = 3N^{4/3} \quad (2.23)$$

And the number of crosspoints per incoming trunk is $3N^{1/3}$

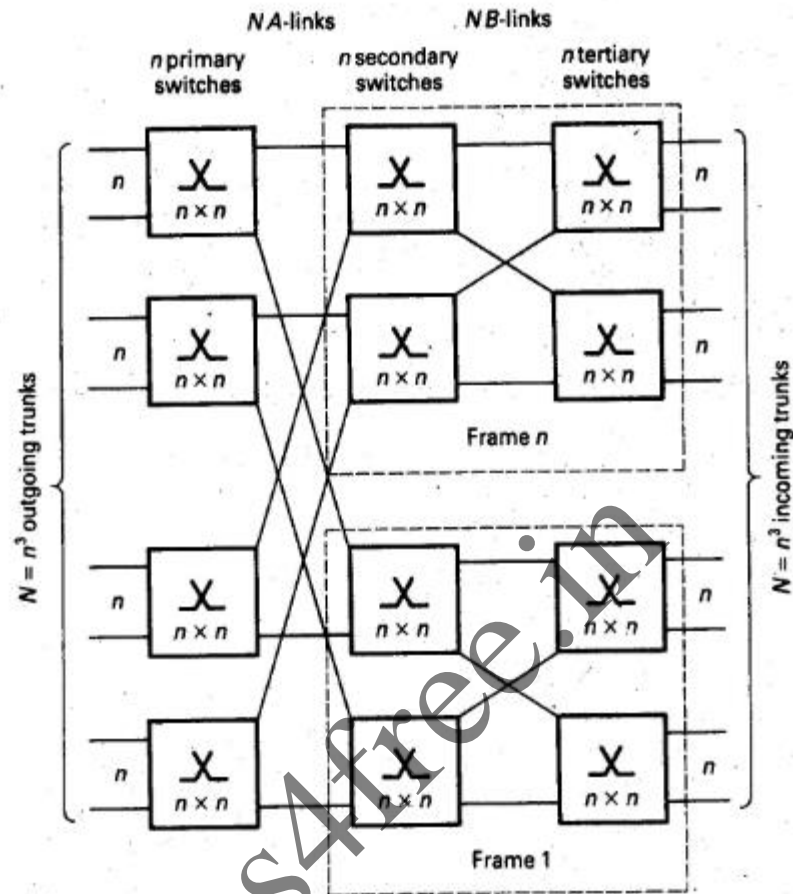

Figure 3.24 Partially interconnected three-stage network.

In Figure 3.23, the third stage added to the two-stage network does not increase the number of outgoing trunks; it increases the mixture of paths available to reach them in order to reduce blocking. The additional stage may therefore be called a *mixing stage*.

In Figure 3.24 the added third stage does not increase the number of paths to an outgoing trunk; it increases the number of outgoing trunks over which the incoming traffic can be distributed. It is therefore called a *distribution stage*.

In Figure 3.23 a primary switch has a link to every secondary switch, so any secondary switch can be used for a connection to a given outgoing trunk. In Figure 3.24, however, there are many more primary switches and each has a link to only one secondary switch of each two-stage frame.

Four-stage networks

A four-stage network can be constructed by considering a complete two-stage network as a single switch and then forming a larger two-stage array from such switches. Figure 3.25 shows a four-stage network for 1000 incoming and 1000 outgoing trunks constructed from two-stage networks (frames) of 100 inlets and 100 outlets using 10 x 10 switches.

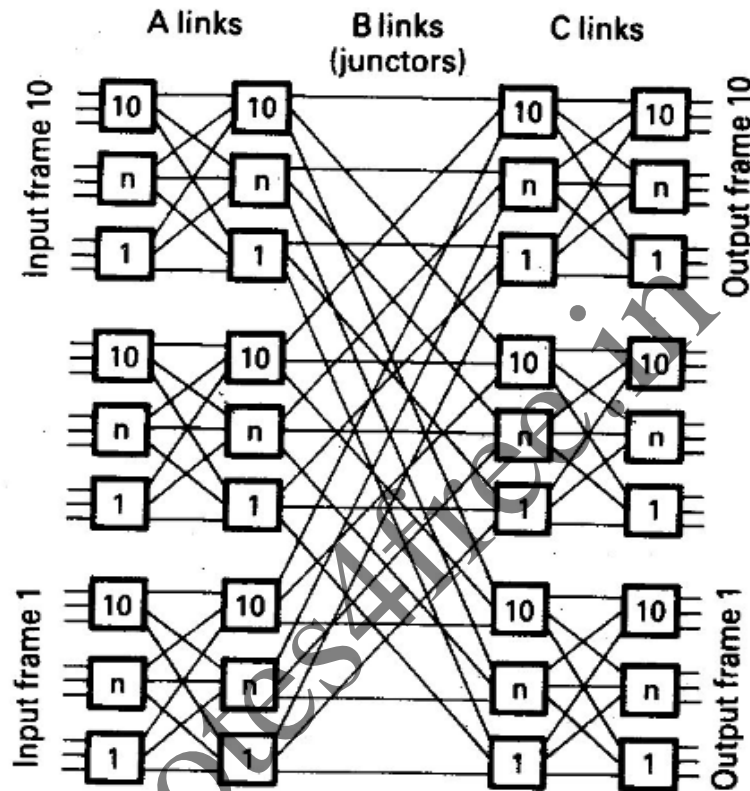

Figure 3.25 Four stage switching network for 1000 incoming trunks and 1000 outgoing trunks using 10 X 10 switches

It is necessary that one trunk (B link) be connected from each secondary switch of an incoming frame to a primary switch of an outgoing frame. These trunks are connected to switches of corresponding numbers on the two frames, thus facilitating marking of the network. Four-stage networks of this type are used in crossbar systems.

If a four-stage network with N incoming and N outgoing trunks is constructed with switches of size $n \times n$, then $N = n^3$ and the total number of switches is $4n^2$

Thus, the total number of crosspoints is:

$$C_4 = 4n^2 \cdot n^2$$

$$= 4 N^{4/3} \text{ -----(2.24)}$$

The number of crosspoints per incoming trunk is $4 N^{1/3}$

It should be noted that the partially interconnected three-stage network of Figure 3.24 corresponds to the four-stage network of previous chapter, truncated at the A links. Adding the fourth stage has not increased the number of trunks, although it has increased the number of crosspoints by one third.

3.14 Grade of Service of Linked systems

General

A Simple theory for calculating the probability of loss in link system, due to C Y Lee concepts explained here

In this method, assumes that trunks and links being busy constitute independent random events.

If two links are connected in tandem, and the probability of one being busy is “p” and if the other being busy is “q” then probabilities of each being free are $(1-p)$ and $(1-q)$ respectively, so the probability of both being free is $(1-p)(1-q)$. Therefore the probability of the path being blocked is $1 - (1-p)(1-q)$.

The occupancy at each stage is the total traffic carried divided by the number links at that stage. However, if the loss is small (as it should be), little error is introduced by using the traffic offered instead of the traffic carried.

In a practical system the assumption of independence may not be valid; because there is usually some degree of dependence between links. This reduces the probability of blocking, because traffic peaks at different stages coincide more often than would happen if they were independent random events.

This overlapping of peaks tends reduce the total time during which blocking occurs. Consequently, Lee's methods over estimates the loss probability. Nevertheless, the method gives reasonably accurate results in most cases. It also has the merit of simplicity. For these reasons, it is widely used.

Two-stage networks

For a two-stage network as shown in Figure 3.22, let the occupancy of the links be a and the occupancy of the outgoing trunks be b . (If the numbers of links and trunks are equal then $a = b$.)

For mode I (i.e. connection to a particular outgoing trunk) only one link can be used. The probability of this being busy is a and this is the probability of loss.

For example, to provide a GOS of $B_1 = 0.01$. each link and outgoing trunk could only carry $0.01E$.

For mode 2 (i.e. connection to an outgoing route with one trunk on each secondary switch) any free link can be used. The probability of loss using a particular link is

$$= 1 - \text{probability that both link and trunk are free}$$

$$= 1 - (1 - a)(1 - b)$$

Let there are g paths available. Assuming that each being blocked is an independent random event, the probability of simultaneous blocking for all g paths is:

$$B_2 = [1 - (1 - a)(1 - b)]^g$$

$$= [a + (1 - a)b]^g \tag{2.25}$$

"Where g is the number of secondary switches

If connection may be made to any outgoing trunk that is free (i.e. mode 3) then it possible to make the connection unless all the outgoing trunks are busy. Thus, if the numbers of incoming trunks, links and outgoing trunks are equal, no calls can be lost.

However, this mode of operation is normally used with a concentrator. The number of incoming trunks is then much larger than the number of outgoing trunks. so the grade of service is given by

$$B_3 = E_{1,N}(A)$$

there A is the total traffic offered to the network.

Problem 3.20

Find the grade of service when a total of 30 E is offered to the two-stage switching network of Figure 3.22 and 3.23. the traffic is evenly distributed over the 10 outgoing routes,

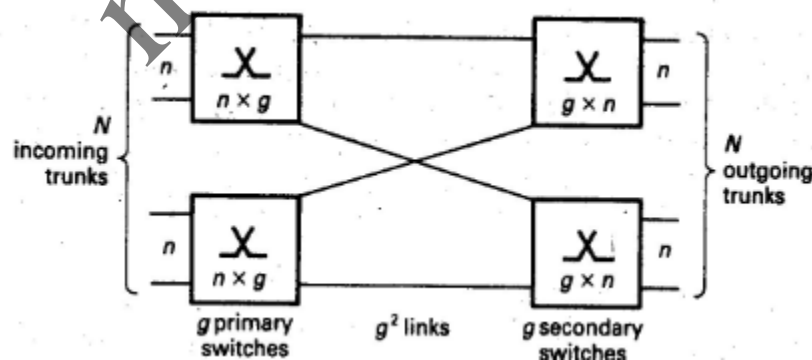

Here $n=10$ and $g=10$

Incoming trunk=outgoing trunk=100=N

Traffic offered=30E

Switch size= 10x10

The link and trunk occupancies are $a = b = A/N = 30/100 = 0.3$ E.

For the two stage network= $B = [1 - (1 - a)(1 - b)]^n$

$$B = [1 - (1 - 0.3)(1 - 0.3)]^{10} = 0.51^{10} = 0.0012$$

1. Find the traffic capacity of the network if the grade of service is not to exceed 0.01.

$$B = [1 - (1 - a)(1 - b)]^n$$

If $a=b$, $n=10$ and $B=0.01$

$$B \leq 0.01 = [1 - (1 - a)^2]^{10}$$

$$1 - (1 - a)^2 \leq 0.01^{0.1} = 0.631$$

$$a \leq 0.39$$

Thus offered traffic is given by,

$A = ax$ number of links or outgoing links or outgoing trunks or incoming trunks

$$A = 0.3925 \times 100$$

$$A \leq 39.25 E$$

Problem 3.21

1. Find the grade of service when a total of 30 E is offered to the two-stage switching network. The traffic is evenly distributed over the outgoing routes. Assume the number of trunks to be 200.

Also find the traffic capacity of the network if the grade of service is not to exceed 0.01.

Solution:

Here $n=40$ and $g=5$

Incoming trunk=outgoing trunk=200=N

Traffic offered=30E

Let Switch size be = 40x40

Number of switches =g=5

The link and trunk occupancies are $a = b = A/N = 30/200 = 0.15 E$.

For the two stage network= $B = [1 - (1 - a)(1 - b)]^g$

$$B = [1 - (1 - 0.15)(1 - 0.15)]^5 = 0.51^5 = 0.001646$$

$$B = [1 - (1 - a)(1 - b)]^g$$

If $a=b$, $g=5$ and $B=0.01$

$$B \leq 0.01 = [1 - (1 - a)^2]^5$$

$$1 - (1 - a)^2 \leq 0.01^{0.1}$$

$$a \leq 0.2242E$$

Thus offered traffic is given by ,

A = a x number of links or outgoing links or outgoing trunks or incoming trunks

$$A = 0.2242 \times 200$$

$$A \leq 44.84 E$$

Three-stage networks

For a fully interconnected three-stage network (as shown in Figure 3.23)

Let Occupancy of A links be a

Occupancy of B links be b

Occupancy of outgoing trunks be c .

For mode 1 (i.e. connection to a particular outgoing trunk), the choice of a second switch determines the A and B links.

Probability that both links are free = $(1-a)(1-b)$

Probability of blocking = $1 - (1-a)(1-b)$

However, there are g_2 secondary switches.

Probability that all g_2 independent paths are simultaneously blocked is

$$B_1 = [1 - (1-a)(1-b)]^{g_2}$$

$$= [a + (1-a)b]^{g_2}$$

Thus, for similar occupancies, the three-stage network provides the same GOS connection is to individual trunks as the two-stage network does for connections group of trunks.

For mode 2 (i.e. a connection to any free trunk in a route having one to connected to each tertiary switch):

Probability of blocking for a particular trunk

$$= 1 - (1 - B_1)(1 - c)$$

$$= B_1 + (1 - B_1)c$$

Therefore Probability of simultaneous blocking for all g_3 independent paths

$$\text{is } B_2 = [B_1 + c(1 - B_1)]^{g_3}$$

Where g_3 is the number of tertiary switches

Problem 3.22

- a. Design three stage network interconnecting 100 incoming trunks to 100 outgoing trunks
- b. Compare the grades of service provided by the two networks of Example when each operates in mode 1 and is offered 30 E of traffic:
- c. What is the traffic capacity of each network if the required grade of service is 0.01?

Solution: (a):

$$\sqrt{\frac{100}{2}} = 7.07$$

use $n = 5$ or $n = 10$

1. If $n = 5$, there are:

20 primary switches of size 5 x 5

5 secondary switches of size 20 x 20

20 tertiary switches of size 5 x 5

If $n = 10$, there are

10 primary switches of size 10 x 10

10 secondary switches 10 x 10 and

10 tertiary switches of size 10 x 10

b). $a = b = A/N = 30/100 = 0.3$ E

(b): $B = [1 - (1 - a) (1 - b)]^g$

i.e. $g = 5 = n$

$$B = [1 - (1 - 0.3) (1 - 0.3)]^5 = 0.51^5 = 0.035 \text{ for } n=5$$

For network (b): $B = 0.51^{10} = 0.0012$

$$B = [1 - (1 - 0.3) (1 - 0.3)]^{10} = 0.012 \text{ for } n=10$$

c) Solution

$$B = [1 - (1 - a)(1 - b)]^n \text{ for } a=b,$$

$$[1 - (1 - a)^2]^5 = 0.01$$

$$1 - (1 - a)^2 = 0.01^{1/5} = 0.398$$

$$a = 0.224$$

$$\begin{aligned} \text{Total traffic capacity} = A &= a \times N \\ &= 100 \times 0.224 = 22.4 \text{ E} \end{aligned}$$

For network (b): $N=100$, $n=5$, $B=0.01$

$$B = [1 - (1 - a)(1 - b)]^n \text{ for } a=b,$$

$$[1 - (1 - a)^2]^{10} = 0.01$$

$$1 - (1 - a)^2 = 0.01^{1/10} = 0.631$$

$$a = 0.393$$

$$\text{Total traffic capacity} = 100 \times 0.393 = 39.3 \text{ E}$$

Partially interconnected Networks GOS

For a partially interconnected three-stage network, as shown in Figure 3.23, there is only one path between an incoming trunk and an outgoing trunk.

The probability that this is free is $(1 - a)(1 - b)$

and the probability of blocking is $1 - (1 - a)(1 - b)$.

For a connection to a trunk on an outgoing route with n trunks, each connected to a different frame, the probability of loss using a particular trunk is

$$1 - (1 - a)(1 - b)(1 - c)$$

But there are n such trunks available. Assuming that each being busy is an independent random event, the probability of simultaneous blocking for all paths is

$$B_2 = [1 - (1 - a)(1 - b)(1 - c)]^n \quad (2.28)$$

Four-stage networks

For a four-stage network, as shown in Figure 3.24 let Occupancy of A links be a

Occupancy of B links be b

Occupancy of C links be c

Occupancy of outgoing trunks be d

For a connection from a given inlet on an input frame to a particular outlet on an output frame (i.e. mode 1), the call may use any primary switch in the output frame. This switch is connected by a Blink to only one secondary switch in the particular input frame. From this switch there is only one A link to the primary switch of the given incoming trunk.

Probability of this path being free is $(1 - a)(1 - b)(1 - c)$

\therefore Probability of this path being blocked is $1 - (1 - a)(1 - b)(1 - c)$

Probability that all g_2 independent paths are simultaneously blocked is

$$B_1 = [1 - (1 - a)(1 - b)(1 - c)]^{g_2}$$

Where g_2 is the number of secondary switches in input frame = number of primary switches in output frame.

For a route of n outgoing trunks:

Probability of loss for a particular trunk

$$= 1 - (1 - B_1)(1 - d)$$

$$= B_1 + (1 - B_1)d$$

\therefore Probability of simultaneous blocking for all n independent paths is

$$B_2 = [B_1 + d(1 - B_1)]^n$$

Problem 3.23

Design a grading for connecting 25 trunks to switches having 12 outlets.

Solution:

The number of graded groups,

$$g = 2 \cdot N/k = 50/12 = 4.1, \text{ and the factors of } g \text{ are } 1, 2 \text{ and } 4.$$

Let the number of choices having singles = s

the number of choices having doubles = d

the number of choices having quadruples = q

substituting in equations

$$s + d + q = 12 \text{ -----(1)}$$

$$4s + 2d + q = 25 \text{ -----(2)}$$

$$\text{From (2) - (1) = } 3s + d = 13$$

Substituting in equations (2.5)

$$s = 1: d = 10 \text{ and } q = 12 - 11 = 1$$

$$s = 2: d = 7 \text{ and } q = 12 - 9 = 3$$

$$s = 3: d = 4 \text{ and } q = 12 - 7 = 5$$

$$s = 4: d = 1, \text{ and } q = 12 - 5 = 7$$

$$s = 5, d < 1 \text{ so this is not possible.}$$

There are thus three possible gradings, which are shown in Figure 2.5. The sums of the successive differences for these gradings are respectively given by:

$$D = |r_1 - r_2| + |r_2 - r_3| + \dots + |r_{q-1} - r_q|$$

$$\text{Case 1) } D_1 = |1-10| + |10-2| \quad D_1 = 9 + 8 = 17$$

$$D_2 = |2-7| + |7-3| = 5 + 4 = 9$$

$$D_3 = |3-4| + |4-5| = 1 + 1 = 2$$

$$D_3 = |4-1| + |1-7| = 3 + 6 = 9$$

Best grading

having Successive Difference is least value is good grading method or allocation.

S=3,d=4 and q=5 then SD=2 (least Successive Difference)

MODULE-4

TIME DIVISION SWITCHING: Introduction, space and time switching, Time switching networks, Synchronization. **SWITCHING SYSTEM SOFTWARE:** Introduction, Basic software architecture, Software architecture for level 1 to 3 control, Digital switching system software classification, Call models, and Software linkages during call, Feature flow diagram, and Feature interaction. [Text-1 and 2]

8 Hours

CHAPTER 1: TIME DIVISION SWITCHING

4.1 Introduction

The first application of digital time-division switching was to provide tandem switching of PCM (Pulse Code Modulation) junctions and trunk circuits. Examples of these systems are Bell ESS (Electronics Switching System) No.4 system and the French E 12 system.

Since a tandem exchange is similar to the route switch in a local exchange, local systems were developed by adding reed-relay space division concentrators. Examples of such system include the initial version of System X and the AXE 10 and E 10 systems.

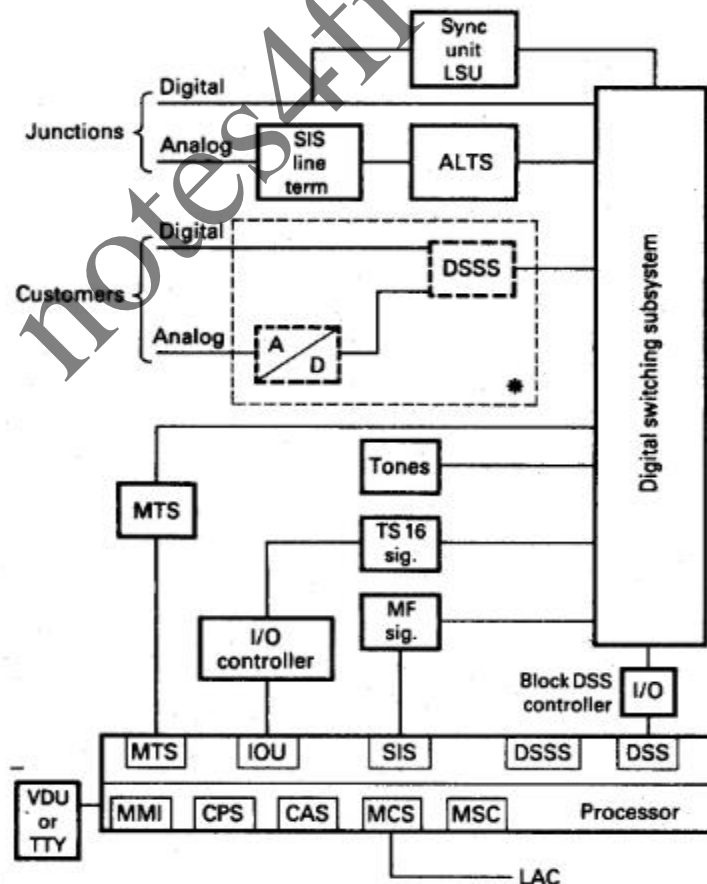

Figure 4.1 system X local exchange

The developments in the technology of solid-state integrated circuits eventually solved the BORSCHT problem and enabled TDM concentrators to replace space division concentrators. This is evolution of integrated digital network

Finally extension of digital transmission over customers' lines has enabled integrated-services digital network (ISDN). It provides the customer with a wide variety of services, based on 64 Kbits/sec digital transmissions, over a single line from a local exchange.

The architecture of a system X local exchange is shown in figure 5.1 the digital switching subsystem (DSS) corresponds to the route switch of Digital switch. The line terminating units of PCM junctions are connected to it directly. Voice-frequency junctions are connected to it directly. Voice-frequency junctions are connected via a signaling internetworking subsystem (SIS) and an analog line terminating subsystem (ALTS) that provides analog/digital and digital/analog conversions.

Analog and Digital customers' line are connected to the DSS via a concentrators, known as the digital subscribers; switching subsystem (DSSS). These concentrators may be in the main exchange or located remotely.

The processor utility subsystem uses software built largely from modules corresponding to the hardware subsystems that they control as shown in figure 4.1

The system has a capacity for 60,000 lines and 10,000 E of traffic. A tandem or trunk exchange uses a similar DSS, but it has no concentrators.

4.2 Space and time switching

4.2.1 General

A tandem switching centre, or the route switch of a local exchange, must be able to connect any channels on one of its incoming PCM highways to any channels of an outgoing PCM highway. A connection will occupy different time slots on the incoming and outgoing highways.

4.2.2 Space switches

Connections can be made between incoming and outgoing PCM highways by means of a cross point. However different channels of an incoming PCM frame may need to be switched by different cross points in order to reach different destinations. The cross point is therefore a two input AND gate. Thus the switching network must be able to receive PCM samples from one time slot and retransmit them in a different time slot. This is known as time switching.

Simple time division switching network make connections between channels on highways carrying a primary multiplex group, i.e. they operate at 1.5 M bits/sec or 2Mbits/sec. A 2Mbits/sec line system has 32 timeslots. It uses 30 speech channels, time slot 0 is used for frame alignment and 16 for signaling. One input is connected to the incoming PCM highways and other to a connection store that produces a pulse at the required instants.

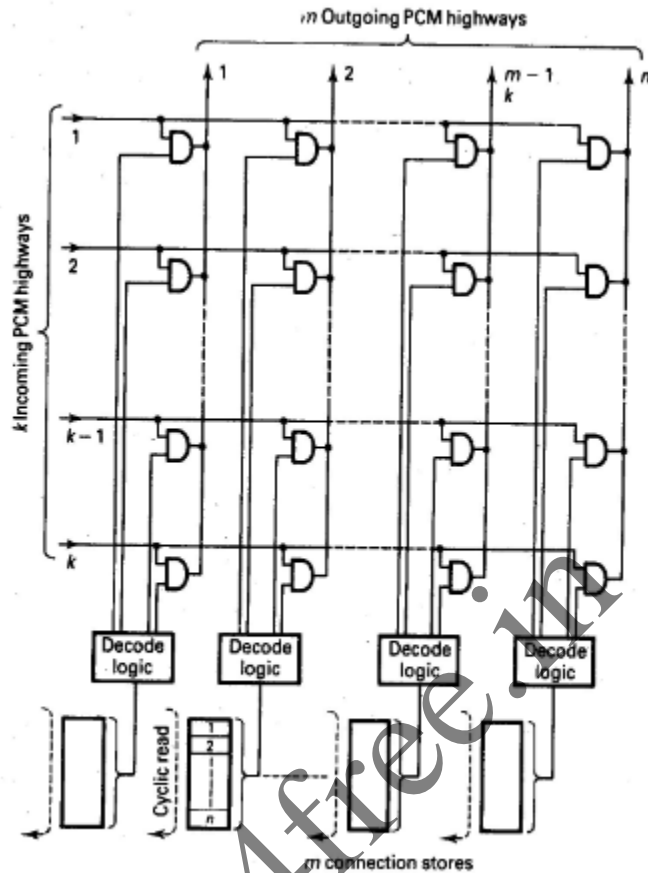

Figure 4.2 space switch

A group of cross point gates can be implemented as an integrated circuit, for example by using a multiplexer chip figure 4.2 shows a space switch with 'k' incoming and 'm' outgoing PCM highways, each carrying 'n' channels. The connection store for each column of cross points is a memory with address location for each time slot, which stores the number of cross point to be operated in that time slot.

4.2.3 Time switches

The principle of Time switch is as shown in figure 4.3(a). It connects incoming n-channel PCM highways to outgoing n-channels PCM highways. Since any incoming channels can be connected to any outgoing channels.

It is equivalent to a space division cross point matrix with "n" incoming and "n" outgoing trunks as shown in figure 4.3 (b).time slot interchange is carried out by means of two stores, each having a storage address for every channels of PCM frame. The speech store contains the data of each incoming time slots at a corresponding address.

Each address of the connection store corresponds to a time slot on the outgoing highways. Information is read into the speech store cyclically in synchronism with the incoming PCM systems; however, random access read out is used. The connection store has cyclic read-out, but writing is non cyclic.

To establish connection, the number (X) of time slot of an incoming channels is written into the connection store at the address corresponding to selected outgoing channel(Y). During the cyclic scan of speech store, the incoming PCM sample from channel X written into address X.

During each cyclic scan of connection store, the number X read out at the beginning of the time slot Y. This is decoded to select address X of speech store, whose contents are read out and sent over the outgoing highways.

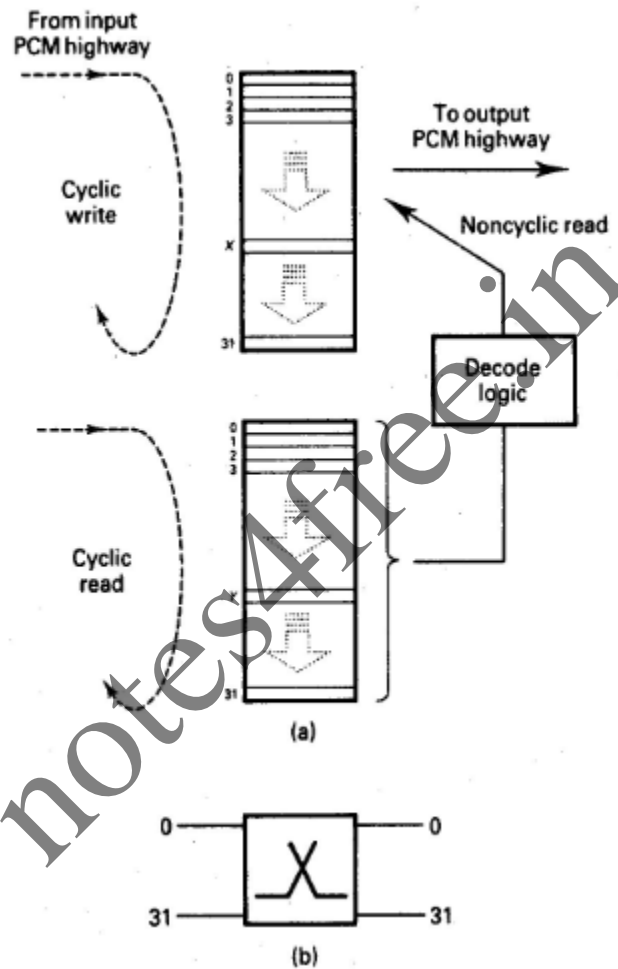

Figure 4.3 Time switching a) Time switch b) Space-division equivalent

4.3 Time switching networks

4.3.1 Basic network

Figure 4.4 shows the space-time-space (STS) switching network. Each of m incoming PCM highways can be connected to k links by cross points in the A switch and the other ends of the links are connected to m outgoing PCM highways by cross points in the C switch. Each link contains a time switch.

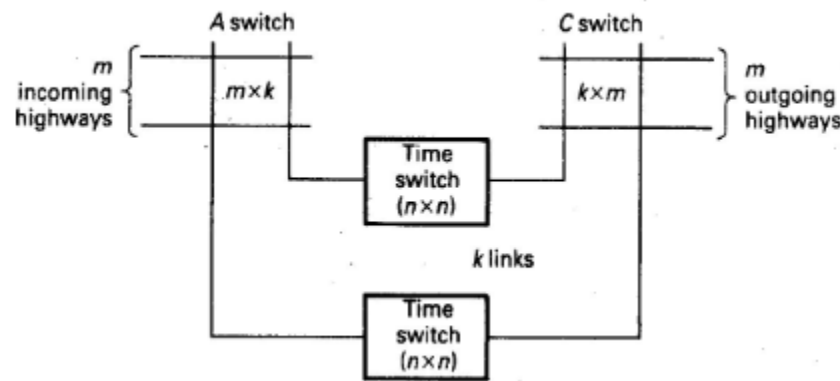

Figure 4.4 space-time-space (STS) switching network m =number of PCM highways, n =number of time slots.

To make the connection between time slots X of an incoming highways and time-slot Y of an outgoing highways, it is necessary to select a link having a address X free in its speech store and address Y free in its connection store. The time switch is then set to produce a shift from X to Y . the connection is completed by operating the appropriate A switch cross point at time X and appropriate C-switch cross point at time Y in each frame.

Time-space- time switch (T-S-T):

Figure 4.5 shows T-S-T switching network. Each of the m incoming and m outgoing PCM highways is connected to a time switch. The incoming and outgoing time switches are connected by space switch.

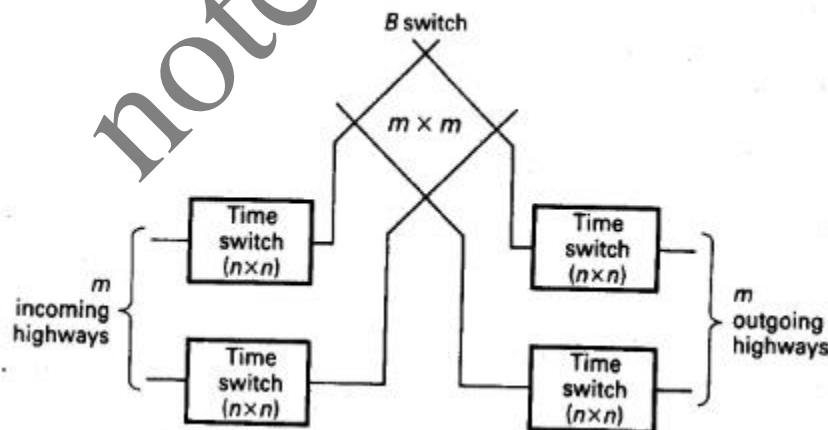

Figure 4.5 Time-Space-Time (T-S-T) switching network m =no. of PCM highways, n =no. of time-slots

To make connection between time slot X of an incoming highways and time slot Y of an outgoing highway, it is necessary to choose a time slot Z which is free, in the connection store of the incoming highway and the speech store of the outgoing highway. The connection is established by setting timer switch to shift from X to Z , setting outgoing time switch to shift from Z to Y and operating appropriate cross point at time Z in each frame.

4.3.2 Bidirectional paths

The switching network S-T-S and T-S-T are unidirectional transmission. Since PCM transmission systems use four wire circuits, it is necessary to provide separate paths for the 'send' and 'receive' channels. One way is provide separate switching network for each direction of transmission. However, this may be avoided by connecting 'send' highways of both incoming and outgoing circuits to one side of the switch and 'receive' highways to other side, as shown in figure 4.6.

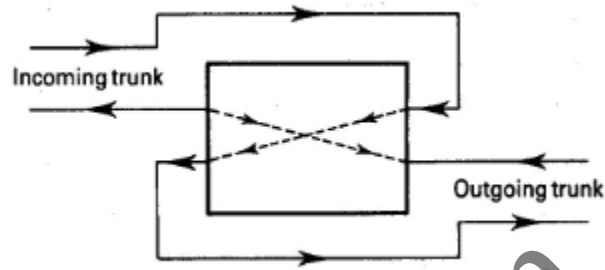

Figure 4.6 Bidirectional transmission through time-division switching network

In an S-T-S network the same speech-store address in the time switch may be used for each direction of transmission. For a connection between time-slot X on one trunk and channel Y on another, for one direction of transmission, the contents at address are written at the end of time slot X and at the beginning of time slot y. For the opposite direction of transmission, they are written at the end of same time-slot Y and read at the beginning of next time-slot X.

In T-S-T network, speech in the two directions must be carried through space switch using different time-slots. In order to simplify through space switch using different time-slot for the two-directions of transmission have a fixed time difference. Usually, the time-slots have phase difference of 180 degrees. In a 32 channels system, if time slot 12 is used for one direction of transmission, then time slot $(12+16) = 28$ is used for reverse direction.

4.3.3 Concentrators

- Concentrators connect to a PCM highway a number of customer's line units greater than number of timeslots on the highway.
- In a simple concentrator, the customer codec are all connected to the common highway and each may use any timeslot.
- A codec is operated in the required time slot by means of a connection store. This method is used in the AXE system. Alternatively, a group of codec's equal to the number of available time-slots (e.g. 24 or 30) uses fixed channels times on a highway.
- The control function of concentrator may be enhanced to enable it to connect calls between its own customers if the PCM link fails.
- Facilities must be added to receive and analyze address signals, generate tones and make cross-switch connections between customer's lines. This unit is then known as a remote switching unit.
- Mark 1 Digital Switching Subsystem DSSS of system X is Shown in figure 4.7

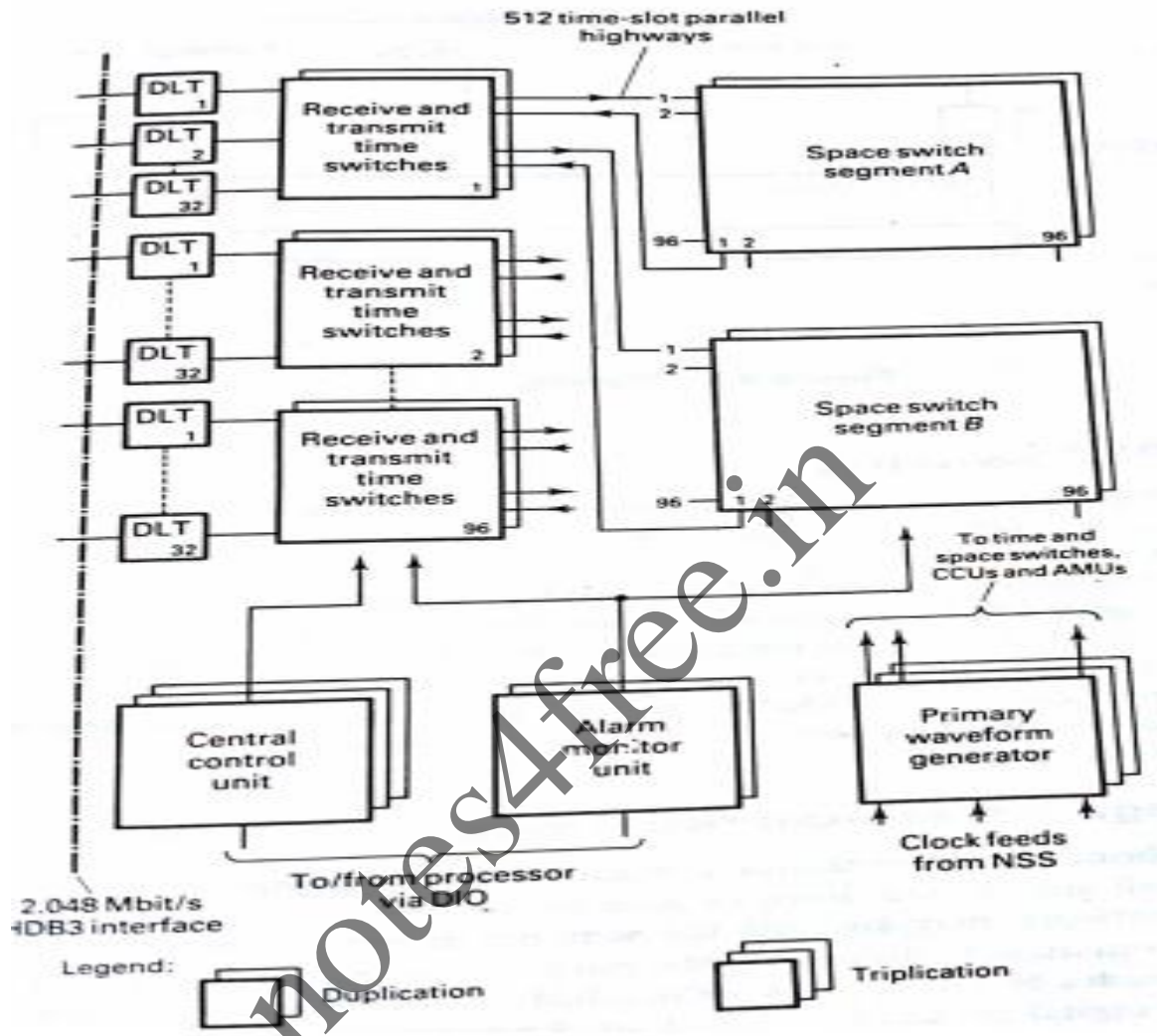

Figure 4.7 Mark 1 digital Switching System of System X. DLT= Digital Line Terminating unit.

4.3.4 PBX switches

A large PBX may use a switching network similar to public exchange. A small PBX may only generate sufficient traffic for all its connection to be made over a single highway. All its ports i.e. those for extension lines, exchange lines and the operator's position, have codec's connected to a common highway, as shown in figure 4.8

The codec's are operated in the required timeslots by a connection store. In order to increase line capacity of PBX, the number of timeslots on the common highways may be increased by using 8-bit parallel transmission instead of serial transmission. Two time slots are used to provide two way communications over same highway.

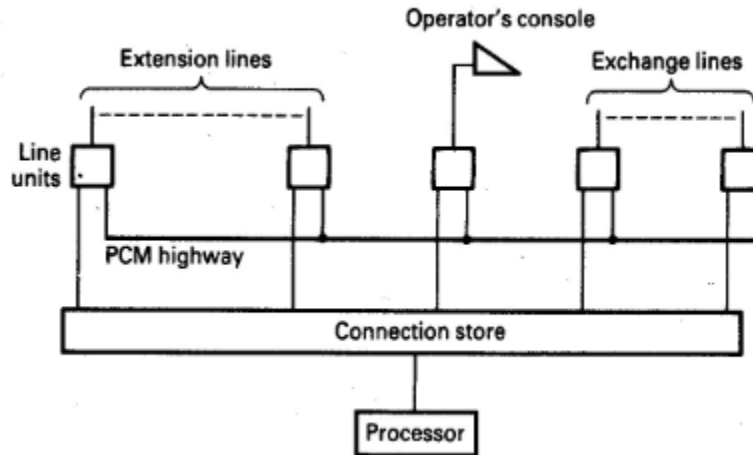

Figure 4.8 Trunking of a digital PBX.

4.3.5 Digital cross connect units

For a telephone call, a connection is made through a digital switching network at the start of a call and cleared down as soon as the call ends. However, a similar digital switching network may be used for semi-permanent connections. It is controlled manually from an operating terminal instead of automatically by processor of exchange. Such digital switching network is called Digital cross connect units. It performs a function for digital circuits similar to that of a distribution frame for analog circuits. It is some time called a 'slow switch', in contrast to a 'fast switch' used to connect telephone calls.

Two functions that can be performed by digital cross connect units are grooming and consolidation. In grooming, 64 k bit/s channels on a common PCM bearer are separated for routing to different destinations. For example a line from a customer's PBX may carry a mixture of PCM channels, some to the public and some to the public exchange and some to other PBXs in the customer's private network. In consolidation, channels onto a smaller number of bearers, thereby improving the utilization of PCM systems.

4.4 Grade of service of time division switching network

4.4.1: S-T-S network

- In the S-T-S network of figure 4.4 each crosspoints of the space switch is time shared by n channels.
- STS is therefore equivalent to " n " separate crosspoints in a space division switch.
- The "A" switch is equivalent to a " n " space division switches of size $m \times k$ and The "C" switch is equivalent to a " n " space division switches of size $k \times m$. Each of k time switches is equivalent to a space division switch of size $n \times n$ as shown in figure 4.3b.
- Hence S-T-S network of figure 4.3 can be rewritten as shown below in the figure 4.9

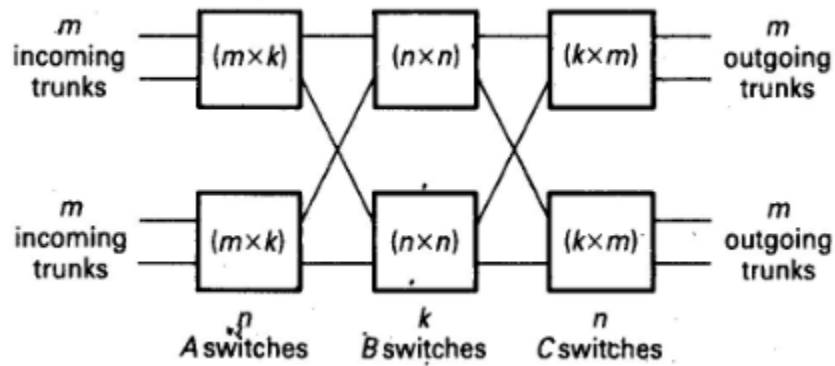

Figure 4.9.Space division equivalent of S-T-S switch: m= number of PCM highways, n=number of Time slots, k= number of time switch links.

Let the Occupancy of A link is a

Occupancy of B link is b

Occupancy of outgoing trunks be c

For mode 1: Connection to a particular Outgoing trunk.

i). Connection is required to a particular free channel on a selected outgoing highway (mode 1)

In this network the choice of secondary switches determines the A and B links

The probability of 1st link being busy = 'a'

Probability of 1st link being free is = (1-a)

The probability of 2nd link being busy = 'b'

Probability of 2nd link being free is = (1-b)

Probability that both the links are free = (1-a) (1-b)

Probability that both the links are busy= blocking probability = [1- (1-a) (1-b)]

However there are g₂ (k) secondary switches.

Therefore the probability that all the g₂ independent paths are simultaneously blocked is:

$$B_1 = [1 - (1 - a)(1 - b)]^{g_2}$$

$$B_1 = [1 - 1 + a + b - ab]^{g_2}$$

$$B_1 = [a + (1 - b)a]^{g_2}$$

Which gives the grade of service for S-T-S switch block

Since $g_2 = k$,

$$B = [a + (1 - b)a]^k$$

If $a = b$, then $B = [1 - (1 - b)^2]^k$

The occupancy of a link is $b = \frac{\text{Total traffic offered in busy hour}}{\text{No. of PCM channel} \times \text{number of links}}$

ii) Connection is required to a particular outgoing highway, but any free Channel on it may be used (mode 2)

The probability of an outgoing trunk to be busy is = “c”

The probability of the outgoing trunk to be free is = “(1-c)”

The occupancy of a link is

$$C = \frac{\text{Total traffic offered in busy hour}}{\text{No. of PCM channel} \times m \text{ incoming or outgoing PCM channel}}$$

The probability of blocking of a particular trunk is given by

$$\begin{aligned} B_2 &= [1 - (1 - B_1)(1 - c)] \\ &= [1 - (1 - B_1)(1 - c)] \\ &= [1 - 1 - B_1 - c + B_1c] \end{aligned}$$

$$B_2 = [B_1 + (1 - B_1)C]$$

The Probability of simultaneous blocking for g_3 (n-tertiary trunks) independent paths is given by

$$\begin{aligned} B_2 &= [B_1 + (1 - B_1)C]^{g_3} \\ g_3 &= n = \text{number of tertiary trunks} \end{aligned}$$

$$\text{Mode 2, } B_2 = [B_1 + (1 - B_1)C]^n$$

Problem 4.1)

- 1) A STS network has 16 incoming and 16 outgoing PCM highways, each of which conveying 24 channels.

Between the incoming and outgoing space switches there are 20 links containing time switches. During the busy hour, the network is offered 300E of traffic and it can be assumed that this is evenly distributed over the outgoing channels. Estimate the required Grade of Services if

- Connection is required to a particular free channel on a selected outgoing highway (i.e. mode 1)
- Connection is required to a particular outgoing highway but any free channel on it may be used (i.e. mode 2) 10M

Given Data: $m=16$, $n=24$, $k=20$ $A=300E$

$$B_1 = [1 - (1 - a)(1 - b)]^{g_2}$$

If $a=b$, then

$$B_1 = [1 - (1 - b)^2]^k$$

$$\text{The occupancy of a link is } b = \frac{\text{Total traffic offered in busy hour}}{\text{No. of PCM channel} \times \text{number of links}} = \frac{300}{24 \times 20}$$

$$b = 0.625E$$

$$B_1 = [1 - (1 - 0.625)^2]^{20}$$

$$= 0.0482$$

Mode 2:

ii) Connection is required to a particular outgoing highway, but any free Channel on it may be used (mode 2)

The probability of an outgoing trunk to be busy is = "c"

The probability of the outgoing trunk to be free is = "(1-c)"

The occupancy of a link is

$$C = \frac{\text{Total traffic offered in busy hour}}{\text{No. of PCM channel } \times \text{ m incoming or outgoing PCM channel}} = \frac{300}{24 \times 16}$$

$$C = 0.781$$

The probability of blocking of a particular trunk is given by

$$= [1 - (1 - B_1)(1 - c)]$$

The Probability of simultaneous blocking for g³ (n-tertiary trunks) independent paths is given by

$$= [1 - (1 - B_1)(1 - c)]^{g^3}$$

$$= [1 - 1 - B_1 - c - B_1 c]^n$$

Mode 2, B₂ = [B₁ + (1 - B₁)C]ⁿ

$$B_2 = [B_1 + (1 - B_1) C]^n$$

$$= [0.0482 + (1 - 0.0482) \times 0.781]^{24} \quad B_2 = 0.0036$$

4.2) An S-T-S network has 10 incoming and 10 outgoing highways. Each of which conveys 32 PCM channels between incoming and outgoing space switches; there are 20 lines containing time switches. During the busy hour, the network is offered 200E of traffic and it can be assumed that this is evenly distributed over the outgoing channel. Estimate the grade of service obtained if,

i). Connection is required to a particular free channel on a selected outgoing highway (mode 1)

ii) Connection is required to a particular outgoing highway, but any free Channel on it may be used (mode 2) 10M

Let the Occupancy of A link is a

Occupancy of B link is b

Occupancy of outgoing trunks be c

i). Connection is required to a particular free channel on a selected outgoing highway (mode 1)

In this network the choice of secondary switches determines the A and B links

The probability of 1st link being busy = 'a'

Probability of 1st link being free is = (1-a)

The probability of 2nd link being busy = 'b'

Probability of 2nd link being free is = (1-b)

Probability that both the links are free = (1-a) (1-b)

Probability that both the links are busy = blocking probability = (1-a) (1-b)

However there are g2 (k) secondary switches. Therefore the probability that all the g2 independent paths are simultaneously blocked is:

Given Data: m=10, n=32, k=20 A=200E

$$B1 = [1 - (1 - a)(1 - b)]^{g2} \text{ here } a=b$$

If a=b, then B1 = $[1 - (1 - b)^2]^k$

The occupancy of a link is $b = \frac{\text{Total traffic offered in busy hour}}{\text{No. of PCM channel} \times \text{number of links}} = \frac{200}{32 \times 20}$

$$b = 200 / (32 \times 20) = 0.3125$$

$$B1 = [1 - (1 - 0.3125)^2]^{20}$$

$$= (0.52735)^{20}$$

$$= 0.0000027668$$

ii) Connection is required to a particular outgoing highway, but any free Channel on it may be used (mode 2)

The probability of an outgoing trunk to be busy is = "c"

The probability of the outgoing trunk to be free is = "(1-c)"

The occupancy of a link is

$$C = \frac{\text{Total traffic offered in busy hour}}{\text{No. of PCM channel} \times m \text{ incoming or outgoing PCM channel}}$$

$$= \frac{200}{32 \times 10}$$

$$C = 0.625$$

The probability of blocking of a particular trunk is given by

$$= [1 - (1 - B_1)(1 - c)]$$

The Probability of simultaneous blocking for g^3 (n-tertiary trunks) independent paths is given by

$$= [1 - (1 - B_1)(1 - c)]^3$$

$$= [1 - 1 - B_1 - c - B_1 c]^n$$

$$\text{Mode 2, } B_2 = [B_1 + (1 - B_1)C]^n$$

$$B_2 = [B_1 + (1 - B_1)C]^n$$

$$= [0.00000276 + (1 - 0.00000276) \times 0.625]^{32} = [0.625001035]^{32} \quad B_2 = 2.93889 \times 10^{-7}$$

4.3). An S-T-S network has 10 incoming and 10 outgoing highways and 10 time switch links. The highway conveys 32 PCM channels. The average occupancy of PCM if channel is 0.7E. i). Estimate the blocking probability ii) Estimate the GOS when an incoming will must be connected to selected outgoing highways but may use any d=free channel on it. 10M

Given Data: $m=10$, $n=32$, $k=10$ occupancy = $a=b=c=0.7E$

$$\text{Mode 1: } B_1 = [1 - (1 - a)(1 - b)]^k \text{ here } a=b$$

$$\text{If } a=b, \text{ then } B_1 = [1 - (1 - b)^2]^k$$

$$B_1 = [1 - (1 - 0.7)^2]^{10}$$

$$B_1 = 0.389.$$

$$\text{For Mode 2, } B_2 = [B_1 + (1 - B_1)C]^n$$

$$B_2 = [0.389 + (1 - 0.389) 0.7]^{32}$$

$$= 0.0015$$

$$b = \frac{\text{Total traffic offered in busy hour}}{\text{No. of PCM channel} \times \text{No. of links}}$$

Total traffic = $b \times \text{PCM channels} \times \text{No. of links}$

$$= 0.7 \times 32 \times 10$$

Total traffic = $A=224E$

4.4.2 GOS of T-S-T network

In the T-S- network of figure 4.5 each time switch is equivalent to a space division equivalent of $n \times n$ and there are m associated incoming highways and m outgoing PCM highways. space switch is equivalent to n space division switches of size $m \times m$. The TST network of figure 4.5 can be rewritten as shown in figure 4.10.

Let the Occupancy of A link is a

Occupancy of B link is b

Occupancy of outgoing trunks be C

The probability of 1st link being busy = ' a '

Probability of 1st link being free is = $(1-a)$

The probability of 2nd link being busy = ' b '

Probability of 2nd link being free is = $(1-b)$

Probability that both the links are free = $(1-a)(1-b)$

Probability that both the links are busy = blocking probability = $[1 - (1-a)(1-b)]$

However there are g_2 (n) secondary switches. Therefore the probability that all the g_2 independent paths are simultaneously blocked is:

$$B^1 = [1 - (1-a)(1-b)]^{g_2}$$

If $a=b$, $g_2=n$, then $B = [1 - (1-b)^2]^n$

For mode 2:

All channels on a route are provided by the same outgoing time switch i.e. all the trunks on a route connected to C switch in the equivalent space division equivalent.

The probability of blocking for a connection to this C switch is B

The probability that all trunks outgoing from the C switch are busy is approximated b^n .

The Probability that connections can be made to a free outgoing trunk is = $(1-B)(1-b^n)$.

And probability of loss $B_2 = [1 - (1 - B_1)(1 - b^n)]$.

Where b is very small and n is very large $b^n \approx 0$ $B_2 \approx B_1$

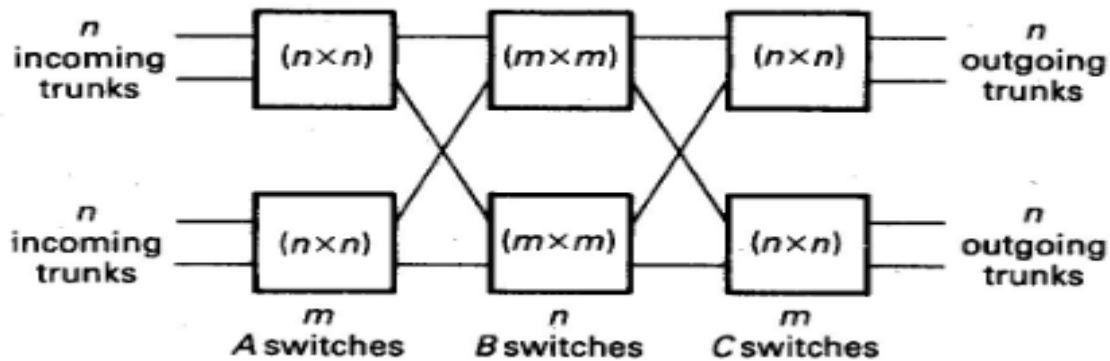

Figure 4.10 Space division equivalent of T-S-T switch. M = number of PCM highways n = number of time slots.

Problem 4.4) A TST network has 20 incoming and 20 outgoing PCM highways, each conveying 30 channels. The required Grade of Services is 0.01. Find traffic capacity of network if

- i) Connection is required to a particular free channel on a selected outgoing highway (i.e. mode 1)
- ii) Connection is required to a particular outgoing highway but any free channel on it may be used (i.e. mode 2)

Solution:

For the equivalent space division network shown in figure 4.10

$m=20, n=20$

let occupancy of the mn links and trunks be b

Let the Occupancy of A link is a

However there are g_2 (n) secondary switches. Therefore the probability that all the g_2 independent paths are simultaneously blocked is:

$$B^1 = [1 - (1 - a)(1 - b)]^{g_2}$$

If $a=b, g_2=n$, then $B = [1 - (1 - b)^2]^n$

$$B = [1 - (1 - b)^2]^{30} = 0.01$$

$$1 - (1 - b)^2 = 0.01^{0.0333} = 0.858$$

$$(1 - b)^2 = 0.142$$

$$b = 0.623$$

Total traffic capacity of network is

Total traffic = $b \times \text{PCM channels} \times \text{No. of link}$

$$= 0.623 \times 20 \times 30 = 374 E$$

For mode 2:

All channels on a route are provided by the same outgoing time switch therefore all the trunks on a route connected to C switch in the equivalent space division equivalent.

The probability of blocking for a connection to this C switch is B_1

The probability that all trunks outgoing from the C switch are busy is approximated b^n .

Therefore The Probability that connections can be made to a free outgoing trunk is $= (1-B_1)(1-b^n)$.

And probability of loss $B_2 = [1 - (1-B_1)(1-b^n)]$.

Where b is very small and n is very large $b^n = 0$ $B_2 = B_1$

If $b=0.623$, $b^{30} = 6.8 \times 10^{-7}$

Therefore $B_2 = B_1$

Thus approximately the same loss probability is obtained in either mode and the traffic capacity of the network for $B_2=0.01$ is again 374E

4.5). A TST network has 10 incoming and 10 outgoing PCM highways, each conveying 32 channels. The average occupancy of the incoming channel is 0.6E.

- i. Design an equivalent space division network**
- ii. Estimate the blocking probability**
- iii. Estimate the GOS when an incoming call must be connected to a selected outgoing highways but may use any free channel on it.**

Given data:

32 channel $m=10$ $b=0.6E$

i).

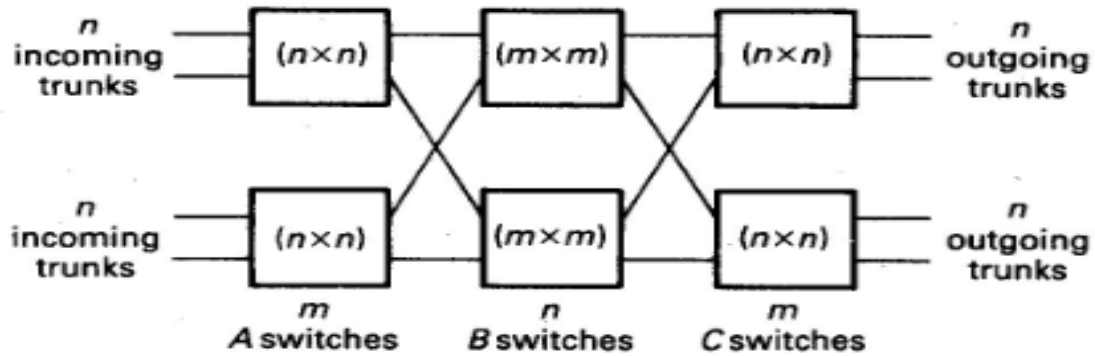

Figure 4.11 space division equivalent of TST

ii).

$$B^1 = [1 - (1 - a)(1 - b)]g^2$$

If $a=b$, $g^2=n$, then $B = [1 - (1 - b)^2]n$

$$B = [1 - (1 - 0.6)^2]32 = 3.77 \times 10^{-3}$$

iii) $B^2 = 3.77 \times 10^{-3}$

4.6). A TST network has 20 incoming and 20 outgoing PCM highways, each conveying 40 channels. The average occupancy of the incoming channel is 0.8E.

- i. Design an equivalent space division network
- ii. Estimate the blocking probability
- iii. Estimate the GOS when an incoming call must be connected to a selected outgoing highways but may use any free channel on it.

Given data: $m=20$, $b=0.8E$, $n=40$ PCM channels

i).

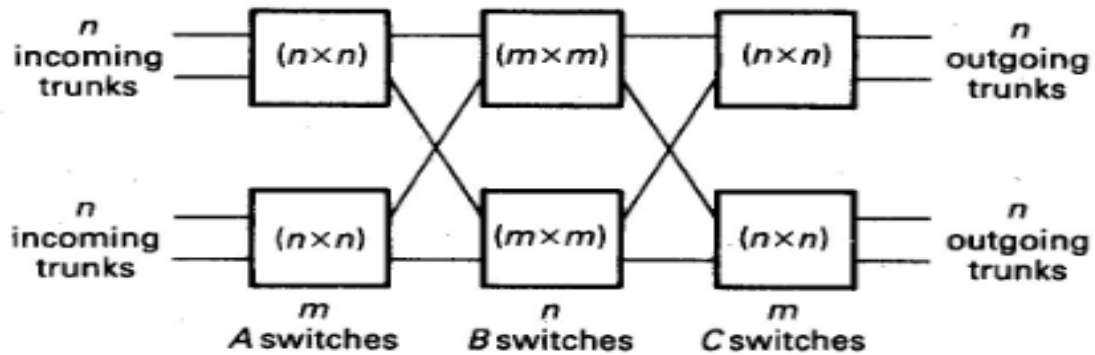

Figure 4.12 space division equivalent of TST

For TST network

$$B_1 = B_2$$

ii). 40 channel $m=20$ $b=0.8E$

$$B^1 = [1 - (1 - a)(1 - b)]^{g^2}$$

If $a=b$, $g^2=n$, then $B' = [1 - (1 - b)^2]^n$

$$B_1 = [1 - (1 - 0.8)^2]^{40}$$

$$= 0.195$$

iii). $B_2 = 0.197$ because for TST network $B_1 = B_2$.

Network has 60 incoming and 60 outgoing PCM highways. Each conveying 40 channels. The required grade of service is 0.7. Find the traffic capacity of the network mode1 and mode2.

$$M=60, n=40 \text{ and } B'=0.7$$

$$B' = [1 - (1 - b)^2]^n$$

$$0.7 = [1 - (1 - b)^2]^{40}$$

$$(0.7)^{1/40} = [1 - (1 - b)^2]$$

$$(0.7)^{0.025} = [1 - (1 - b)^2]$$

$$0.9911 = [1 - (1 - b)^2]$$

$$(1 - b)^2 = [1 - 0.9911]$$

$$= 0.0089$$

$$1 - b = 0.094$$

$$B = 0.904$$

$$\text{The } b = \frac{\text{traffic offered}}{\text{No. of PCM highways} \times \text{links}}$$

$$0.904 = \frac{\text{traffic offered}}{40 \times 60}$$

$$\text{Traffic offered} = 2174$$

$$\text{Therefore } B_1 = B_2 = 2174$$

4.5 Synchronization.

4.5.1 Frame alignment

For correct operation of a time division switching network the PCM frames on all the incoming highways must be exactly aligned. However, since incoming PCM junctions come from different places, their signals are subjected to different delays. To solve this problem, the line terminating unit of a PCM junctions store the incoming digits in a frame alignment buffer as shown in figure 4.8. Digits are read into this buffer at a rate f_a of incoming line, beginning at the start of PCM frame of the exchange. A frame alignment buffer caters perfectly constant misalignment.

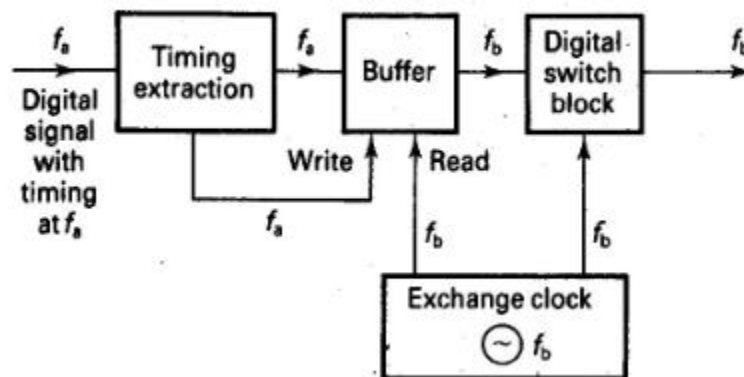

Figure 4.8 Frame alignments of PCM signals entering a digital exchange.

The fill of buffer is constant and its level depends on the phase difference between incoming line system and the exchange. It will also cope with a misalignment that changes slowly between limits (e.g. due to temperature changes in cables).

4.5.2 Synchronization network.

In a Synchronous digital network just one or two atomic reference clocks control the frequencies of clocks, of all exchanges in the network. This is called despotic control.

Synchronizing links may be unilateral or bilateral. In the first case, there is master-slave relationship; the clock frequency of the exchange influences the frequency of the other.

For this purpose, synchronizing network is added to the PSTN in order to link the exchange clocks to the national reference standard.

The local clock in each exchange is provided by a crystal oscillator whose frequency can be adjusted by a control voltage. This control voltage is derived from the incoming digit stream on a synchronizing link, which is used to determine whether the exchange clock rate should be increased, decreased or left unchanged. This ensures that exchanges maintain the same long term average frequency, although short term variation may occur. This is known as mesochronous working. clock frequency of the exchange influences the frequency of the other. In the second case, there is a mutual relationship; each exchange influences the frequency of the other. The principles of these methods are shown in figure 4.9.

A unilateral sync system is shown in figure 4.9(a) exchange A is the 'master' and exchange B is the 'slave'. Exchange B determines the phase difference between its own clock and that of the exchange A by fill of the aligner buffer on the incoming link. If there is a more than one sync network link into exchange B, its correction is based on a majority decision.

In a single ended bilateral sync link, as shown in figure 4.9(b) the above decision process is made at each end of the link. As a result, both exchange clocks achieve the same average frequency. In a mesh of such synchronous nodes, the exchange would mutually agree on a common frequency without being controlled by an overall master clock. A disadvantage of single ended unilateral and bilateral synchronous system is that phase comparators are unable to distinguish between phase changes due to frequency drift and those due to changes in propagation time. This disadvantage of single ended unilateral and bilateral synchronous system is overcome by double ended system as shown in figure 4.9(c) and (d).

Synchronizing links may be unilateral or bilateral. In the first case, there is master-slave relationship; the

This eliminates the influence of propagation-delay variations by subtracting the change in phase determined at the end of link from that determined at the other end.

Let the phase error detected at exchange A be $\delta(\phi_A - \phi_B) + \delta\phi_T$, where $\delta(\phi_A - \phi_B)$ is the phase change due to discrepancy between the clocks and $\delta\phi_T$ is that due to a change in propagation time. Then the phase change detected at exchange B is $\delta(\phi_B - \phi_A) + \delta\phi_T$. Since $\delta(\phi_B - \phi_A) = -\delta(\phi_A - \phi_B)$, the difference between the two measurements is $2\delta(\phi_A - \phi_B)$ and the $\delta\phi_T$ is eliminated. A signaling channel is required to carry the result of phase comparison to the other end of link in order to make subtraction.

For a unilateral network, as shown in figure 4.9(c), this channel is needed in only one direction. For a bilateral link, a signaling channel is needed in each direction as shown in figure 4.9(d).

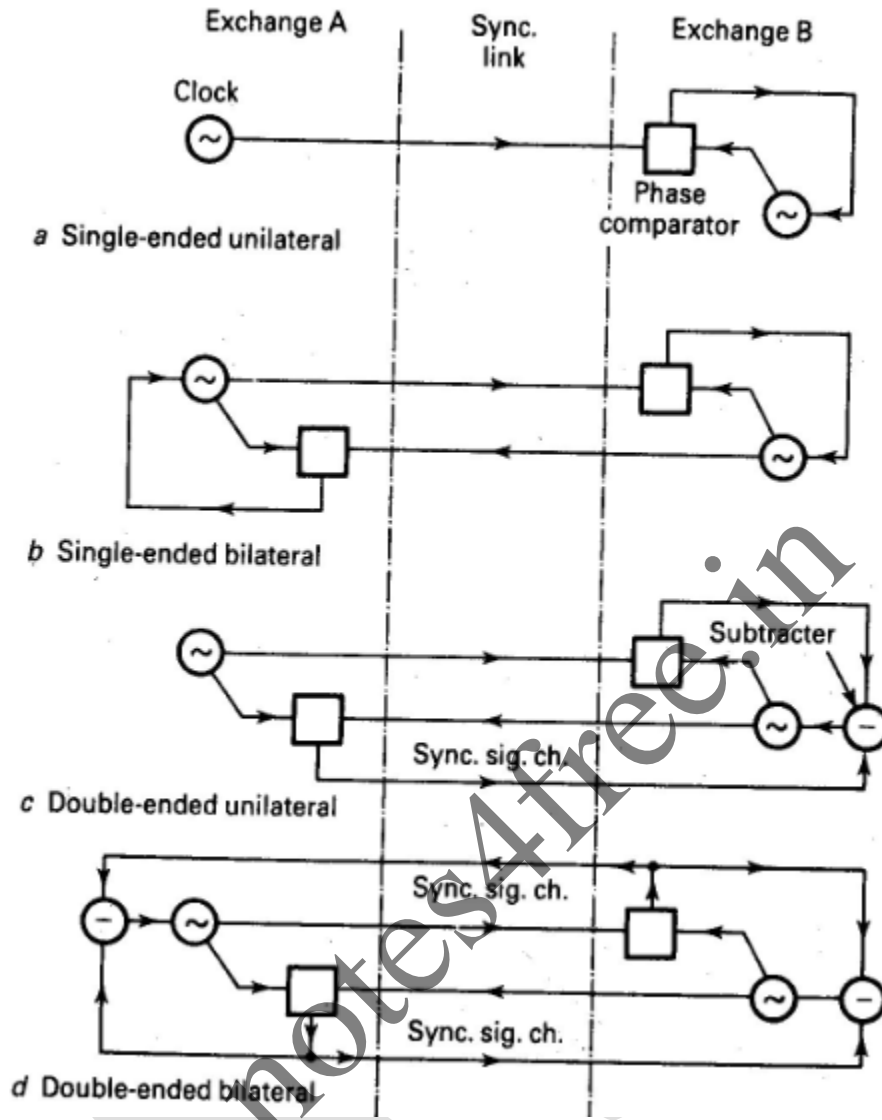

Figure 4.9 Exchange synchronization system

A synchronizing network for an integrated Digital Network (IDN) is shown in figure 4.10 since this auxiliary network must link all exchanges in the IDN. The synchronous network has same nodes and the same hierarchical structure as the parent public switch telephone network (PSTN). The synchronous links are provided by PCM systems that carry normal traffic between the exchanges.

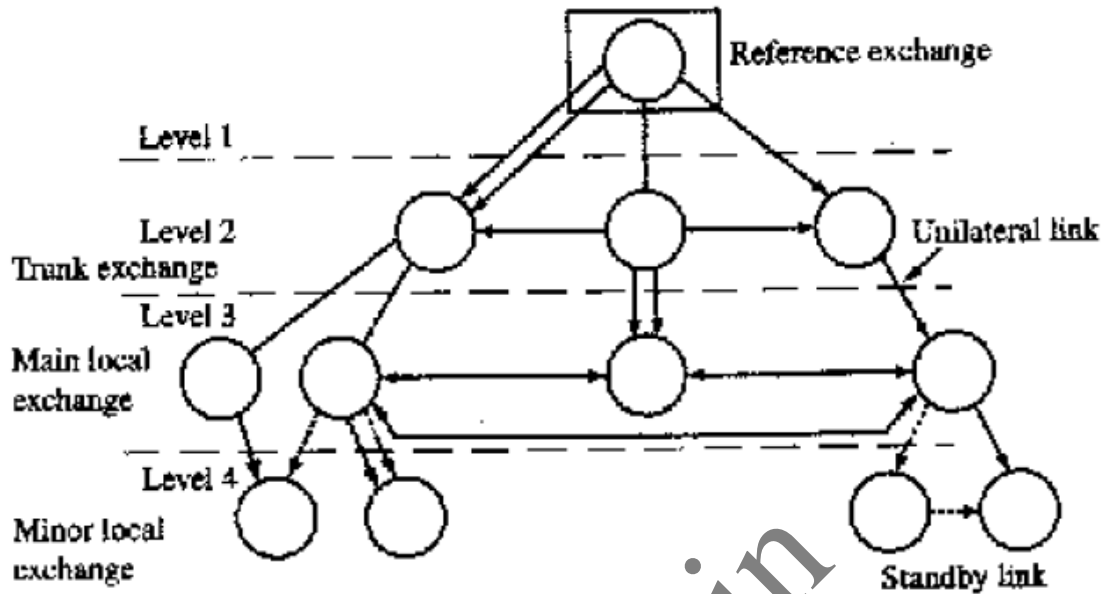

Figure 4.10 synchronization hierarchy of an integrated digital network.

CHAPTER 2: SWITCHING SYSTEM SOFTWARE

Introduction, Scope, Basic software architecture, Call models, and software linkages during a call and call features.

4.6 Introduction

A modern digital switching system is quite complex. The growth in the field of software, the complexity of the DSS also increases. This chapter exposes workings of the software that drives a digital switching system.

4.7 Scope

The scope of this unit is to learn

- basic software architecture of a typical digital switch
- classifies various types of software
- describe the Call model and
- Software linkages that are required during call and Basic call features.

4.8 Basic software architecture

Modern digital switching employs quasi-distributed hardware and software architecture. The software employed in the modern digital switching system at different levels of control. Figure 6.1 shows the basic software architecture of a typical digital switching system. Figure shows the levels of the control and minimum software requirement at each level of control. Here both high-level and low-level details are necessary to design the switching system.

1. Operating systems

Modern digital switching system consists of an operating system as a part of the software architecture, operating systems (OS) may be defined as software that manages the resource of a computer system or controls and tasks other programs.

These programs are also called as control programs, supervisory programs and monitor programs as a part of the software architecture. There are different types of operating systems. They are

- Serial batch systems
- Multiprogramming system
- Time sharing system and
- Real time systems.

The OS employed by the DSS are Real time operating systems because modern DSS demands for the task to execute in the real time. Typically the real time operating system of a DSS interacts with different layers of the application required to support telephony features and functions. Most modern DSS uses quasi-distributed architecture; the processor or the controller for each of the subsystem may use different OS.

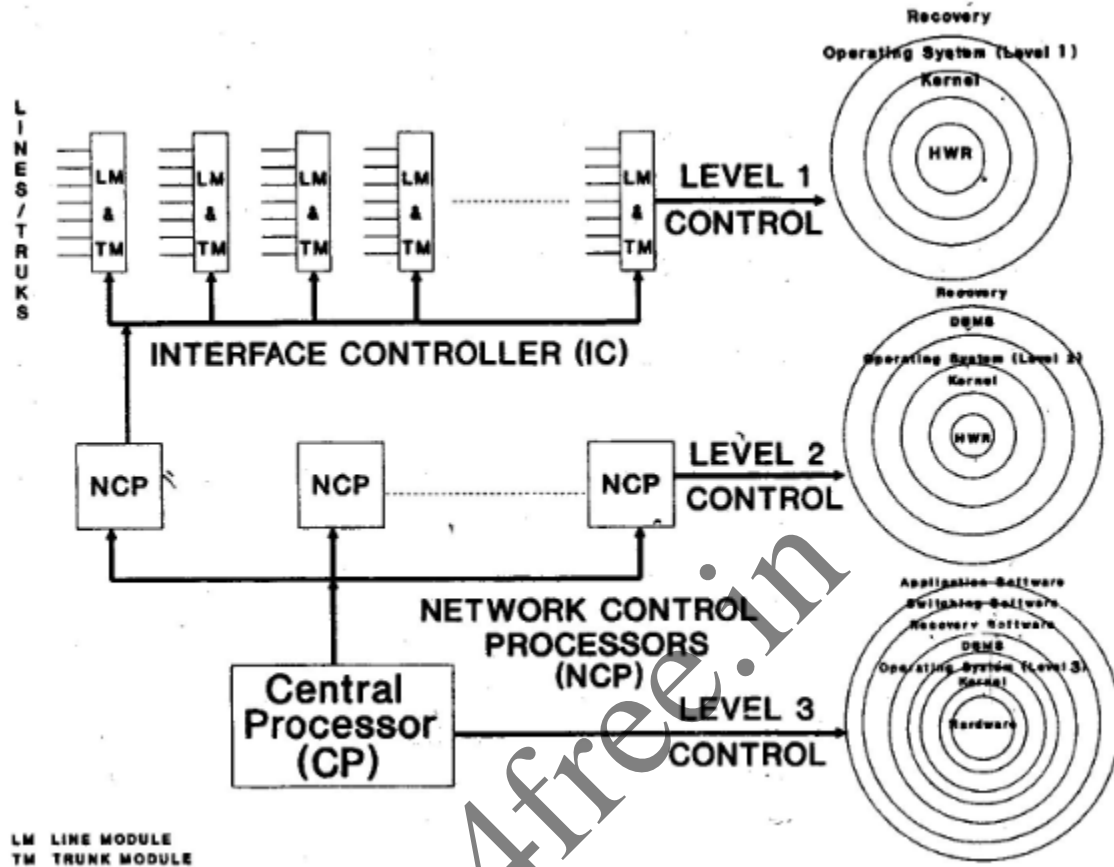

Figure 4.11 shows the basic software architecture of a typical digital switching system.

2. Kernel

The kernel of the operating system consists of those functions of an operating system that are primitive to the system environment. It usually consists of the following functions.

- Process control and process scheduling
- Memory management
- Input and output control i.e. request from the terminal and buffers.
- Domain protection of main memory Read and write operations.

Most of real time operating system that controls the DSS use priority based scheduling mechanism. Most DSS employs Kernels that reside in the main memory. The highest priority given to system maintenance interrupts followed by other types of interrupts required for call processing and other ancillary functions.

3. Database Management

The databases that are employed in the DSS are usually relational and sometimes distributed. Distributed databases imply multiple databases requiring data synchronization. The relational

databases system uses the relational data model in which the relationships between files are represented by data values in file *records*.

A record in a relational database is flat, i.e., a simple two dimensional arrangement of data elements. The grouping of related data items is sometimes referred to as a **tuple**. A **tuple** containing two values is called a pair. A **tuple** containing N values is called an **N-tuple**.

An example of relational database in case of DSS is a database, which cross references all the directory names that are assigned to a line equipment of subscriber. When a subscriber goes off-hook, the scanning equipment identifies the line equipment. The database is searched to find the particular directory number that identifies all characteristics of the line.

4. Concept of generic program

The generic program contains all programs necessary for the switching system to functions. It consists of operating system, common switching software, and system maintenance software and configuration management of a central office (CO). The translation of the data between the customer premises and CO side is provided by the telephone companies.

Most of the DSS have modular software structure. Most of the modular switching system employ generic program concept. Due to growth in the software, it is very difficult to define the generic program with respect to particular switching system.

Generally most of the switching system consists of *base* or *core* program that controls the basic functionalities of the system and on the top of these programs reside the basic features and special options required by the switching system. The quality and the performance of the switching system are based in the reliability of the components used and stability of the software programs.

A group of telephone companies are sometime used to identify the generic program. Usually, this set of programs can be labeled as a generic, base or core release for a DSS.

In general, generic program contain operating system, common switching software, system maintenance software and common database(s) software for office data and translation data management.

5. Software architecture for level 1 control

The lowest level of control in switching system architecture is level 1 control. This level consists of lines, trunks and other low level functions and software at the level is a part of the switching software.

As shown in the figure 6.1, the interface controllers (ICs) are controlled by microcontroller and have a small kernel controlling the hardware of the IC. IC will have small OS (level 3) to control and scheduling the tasks.

The IC do diagnostics of lines and trunks and other peripherals associated with the hardware. Diagnostic routines reside in central processor or in the IC itself. Central processor can run the diagnostic routines program itself or request a fault-free IC to run it.

The interfaces will diagnostics and submit the result to the central processor. In any case of failures the IC should have the ability to recovery locally and make the central processor to deliver better performance.

6. Software architecture for level 2 control

The next level of the switching system architecture is named as level 2 control; this level is associated with network controllers that may contain relational database or distributed database, customer database, and service routines.

At this level the central processor (CP) are usually associated with the network control processors (NCP). NCP is independent of the CP as shown in figure 4.11 the NCPs has their own OS has a kernel that control the hardware and software functionalities of the NCP.

At this level of control the database system maintains the translation of the data between the subscriber and parameter required to control the NCP. So at this level, system recovery is very crucial in order to avoid failure of NCP, because that impact on the interfaces such as lines, trunks, and peripherals.

The NCP should have the ability to diagnosis and switch to working backup. The design of NCP depends on the requirement raised by the DSS. The recovery mechanism in case of failure of NCP is depends on the requirement. Either a central NCP may responsible for recovery of all NCPs or central processor is responsible.

The basic functionality of a NCP: When a subscriber goes off-hook, the interface receives an off-hook notification from the line modules. The interface requests details on the subscriber, such as allowed feature and application restriction for a call to process. The NCP maintains the subscriber database; NCP queries its database for this information and passes it back to Interface Controller. This database is supposed to be managed and kept up to date with the latest information for each subscriber.

7. Software architecture for level 3 control

The top level of switching system architecture is level 3, is usually associated with the central processors of a DSS. These central processor are mainframe type computers, provides the all high-level functions. These functions include the database management such as office data, high level subscriber data, software patch level, feature control, maintenance data and system recovery in case of hardware or software failures.

Modern DSS contains OS at this level 3; the OS is real time operating system and performs multitasking (i.e., it can support more than one call at a time). Operating system is responsible for database management, switching software, recovery software, feature control, traffic control and interface with other components' of the DSS.

Most central processor works as active/standby mode, because if one goes to standby mode other one enters into active mode state, this improves the reliability of the DSS. In active/standby mode one CP is always available to go into active mode if the active CP develops faults.

We have different mode like matched mode, hot standby and cold standby mode. However both should be synchronized in order to carry the functionality in case of failure, then standby processor becomes active.

8. Digital switching system software classification

Typical DSS software is shown in figure 4.12. The functionality of a DSS can be divided into five basic elements and other functions can be derived from these basic elements.

- Switching software
- Maintenance software
- Office data
- Translation data
- Feature software

Switching software

The most important layer of software for a digital system consists of

- Call processing software
- Switching fabric control software
- Network control software
- Peripheral device control software

Switch maintenance software

- The most important role of the maintenance software is to control the DSS software and related hardware such as line test, remote diagnostics, system recovery and trunk tests.
- The recovery software of a modern DSS is distributed among all the subsystem, which controls the switching system. This method allows the system to recovery from faults more efficiently.
- Digital switching system may employ a large number of programs that are external to the system, such as remote programming and diagnostics, operational support systems (OSSs), operator position support, and advanced features (e.g., ISDN,NCP,AIN).The objective of Figure is to provide the analyst with clear picture of the digital switch software.

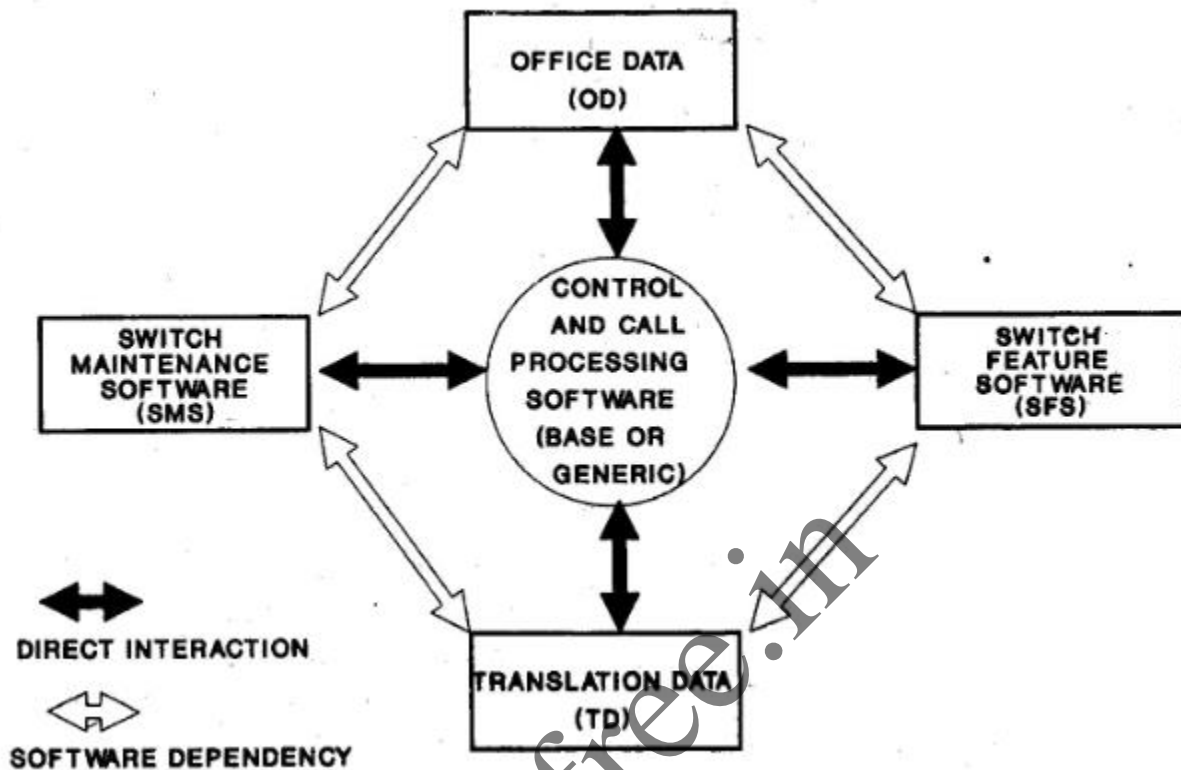

Figure 4.12 The classification of digital switch software.

Office data

Office data defines the software parameters along with the hardware equipment. Office data of a DSS describe the extent of a central office (CO) to the generic program. Some general hardware parameters are

- Number of NCP pairs in the Central office.
- Number of line controllers in the Central office.
- Number of lines configured in the Central office.
- Total number of line equipment in CO.
- Total number of trunks and types of trunks configured in the Central office
- Total number and types of services circuits in the CO. services such as ringing units, and DTMF and Dial Pulse (DP) receiver and transmitter are provided.

The software parameters are as follows

- Size of the automatic message accounting (AMA) registers.
- Number of AMA registers.
- Number and types of traffic registers
- Size of buffers for various telephony functions
- Names and types of features supported

Translation data

Translation is the data given by the subscriber and is specific to each subscriber. The telephone companies provide translation data. The database and the entry for the translation data is a part of the DSS. Translation data may consist of the following.

- Assignment of directory number to a line equipment number.
- Enabling the feature subscribed by a particular customer, such as call waiting, conference call and call forward.
- Call restriction, such as no outgoing calls, certain call blocked.
- Intercom and call announce.
- Area code translator, identifying the call route calls, STD calls and international calls.

The CO should maintain the database about the routing of specific calls. If a new central office is installed information about the traffic is provide by the telephone companies.

Features software

Most features implemented in modern DSS are offered through feature packages. Some of the feature packages are put in a feature group and are offered to a group telephone companies. These features may be included in the base packages of a generic release. Most of the features are considered to be applications of a digital switch. Some examples of the feature packages are

- Operator services
- Centrex feature
- ISDN basic rate
- STP extensions
- SCP database.

Depending on the DSS, these feature packages can be extensive and large.

Software dependencies

Most telephony feature of DSS requires specific office data and translation data for their operation. They depend on the generation of feature-specific office data and/or translation data. These dependencies are, design specific.

Similarly the maintenance programs also require office data and translation data for testing feature functionality of DSS. It is shown in figure 6.2

4.8. Call models

The call model describes the basic connection between the hardware and software that are necessary for connecting and disconnecting a call. Call model is dependent on the type of call. A basic call model is shown in the figure 4.13.

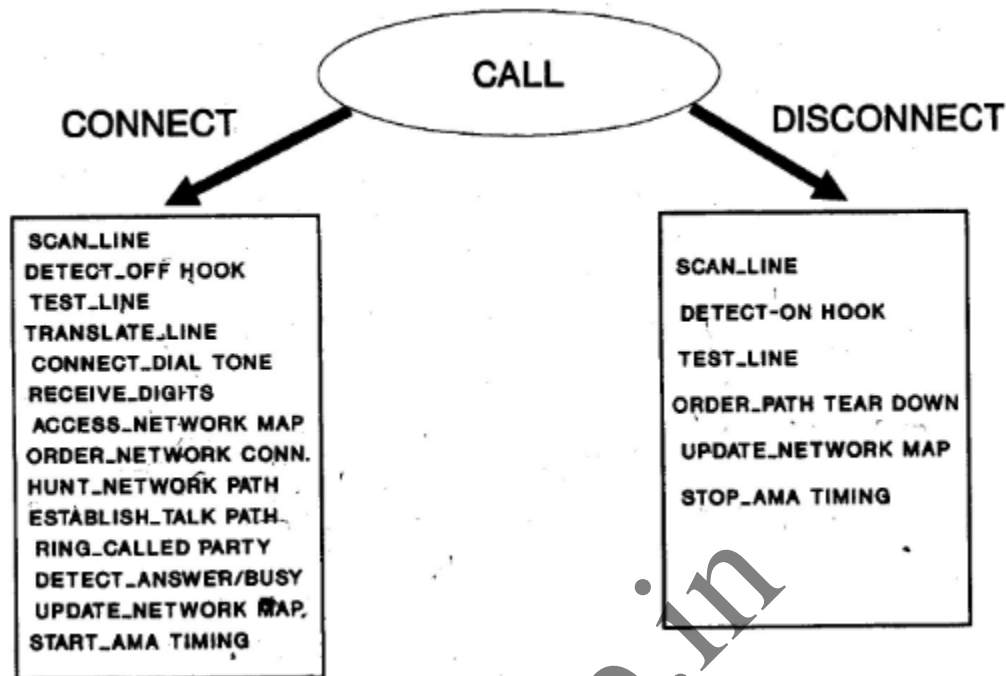

Figure 4.13. A basic call model

Connect sequence:

Connect sequence consists of software routines that scan the line and detect request for originations. Connect sequence of a call has to follow a set of software procedure to be invoked in order to accept the request. First step of the Connect sequence is to scan line, once the line is detected that indicated line has gone off-hook and it is the legitimate request for the dial tone.

The off-hook program passes on the control to the test line program, these program tests for the presence of false-ground, high-voltage, line cross, and other conditions. After successful completion of these tests a dial tone is returned to subscriber, signaling the user to dial the digits. These steps must be completed in less than 3 seconds.

Once subscribers enter the digits the dial tone is removed and the digits are collected in the buffer. After the correct number of digits received from the subscriber, switching fabric map is consulted. Network control orders are then issued to establish a talking path through the switching fabric.

After completion of the path, the ringing service circuit is connected to the called party, and ringing is initiated. When the called party answers the call, the billing and accounting times are started.

Disconnect sequence:

The disconnect sequence is shown in figure 4.13. The lines are constantly scanned for disconnect from either end users. Once off-hook is detected from either of the party, then switching network issues an order to tear down the call. Once the call is disconnected the billing software timer is stopped.

4.9 Software linkages during Call

In order to processor a call through a DSS requires software linkages, an example of Software linkages required during a typical call is shown in figure 4.14. The line control programs scan the LMs and report the status to the network status program, which intern work with network control programs.

The line control programs also work with the line service circuit programs in providing the dial tone, digit receivers, ringing circuits, etc., to the subscriber lines. The network control program is responsible for notifying the network connection when a subscriber goes off-hook and feed a dial tone, when the subscriber stops entering the digits.

The call processing program is responsible for processing a call, accounting a call, message wait indication and maintenance programs.

The maintenance programs are responsible for system recovery, remote diagnostics, backup of software, and maintenance related programs. All these programs are responsible for processing a call. If the called party is not in the same digital switch, then an outgoing trunk is used to establish a call between the two parties through the switching network. While here line and outgoing trunk is constantly scanned to disconnect from either of the party.

If the called party and calling party reside in the same Digital switch then it is called as intra-office call. If the called party and calling party reside on the different Digital switch, then it is called as inter-office call.

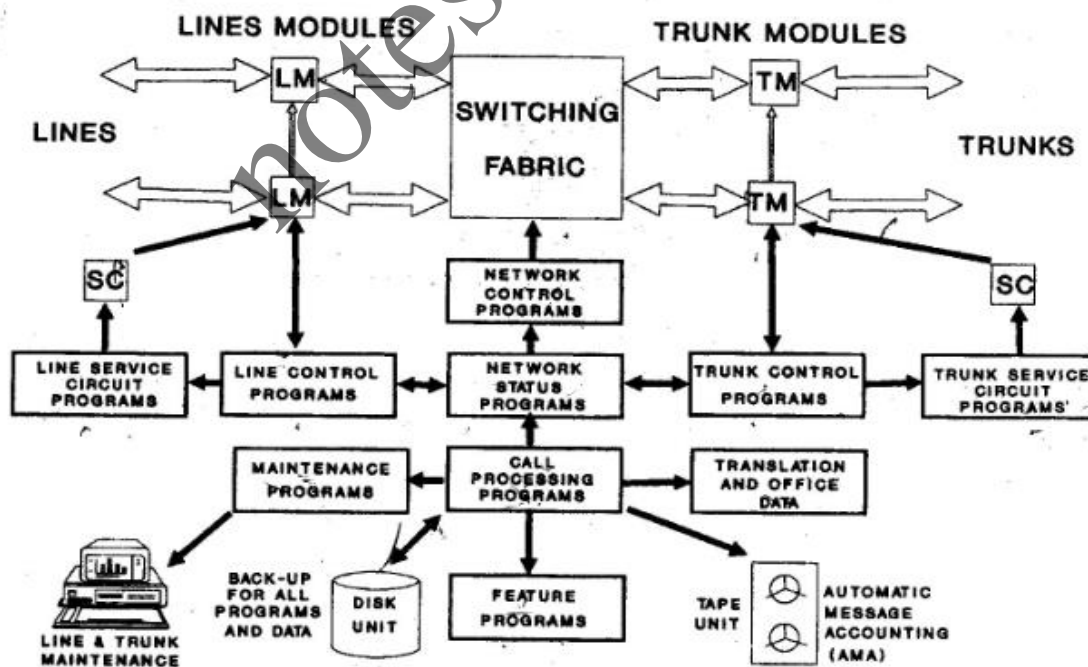

Figure 4.14 Software linkages required during a typical call

4.10 Call features

The basic functions of an end office digital switching system are to provide telephony services to its customers. The modern DSS contain several features. The features supported by DSS depend on the customer requirement. These requirements are divided into the following categories:

- Residence and business customer features
- Private facility access and services
- Attendant features
- Customer switching system features
- Customer interfaces
- Coin and charge-a-call features
- Public safety features
- Miscellaneous local system features
- Interoffice features
- Call processing features
- Database services
- Data services
- System maintenance features
- Trunk, line, and special service circuit test features
- Administrative features
- Cut-over and growth features
- Billing and comptrollers features

a. Feature flow diagrams

The features employed in the DSS are usually very complex. The functionality of features can be understood with the help of Flow diagrams.

The simplified flow diagram for one of the most commonly used subscriber features; call forwarding is shown in figure 4.15. This feature has three modes of operation. They are

- Feature Activation
- Feature Operation
- Feature De-activation

Feature Activation

The Feature is activated when the customer goes off-hook and dials an activation code.

The software checks for the correct validation code. If the activation code is wrong, the subscriber does not get the second dial tone.

If the activation code is correct, the subscriber gets a second dial tone and is allowed to dial the call forwarding telephone number.

The call-forwarded subscriber line is rung once, and the number is recorded in the system memory for future use.

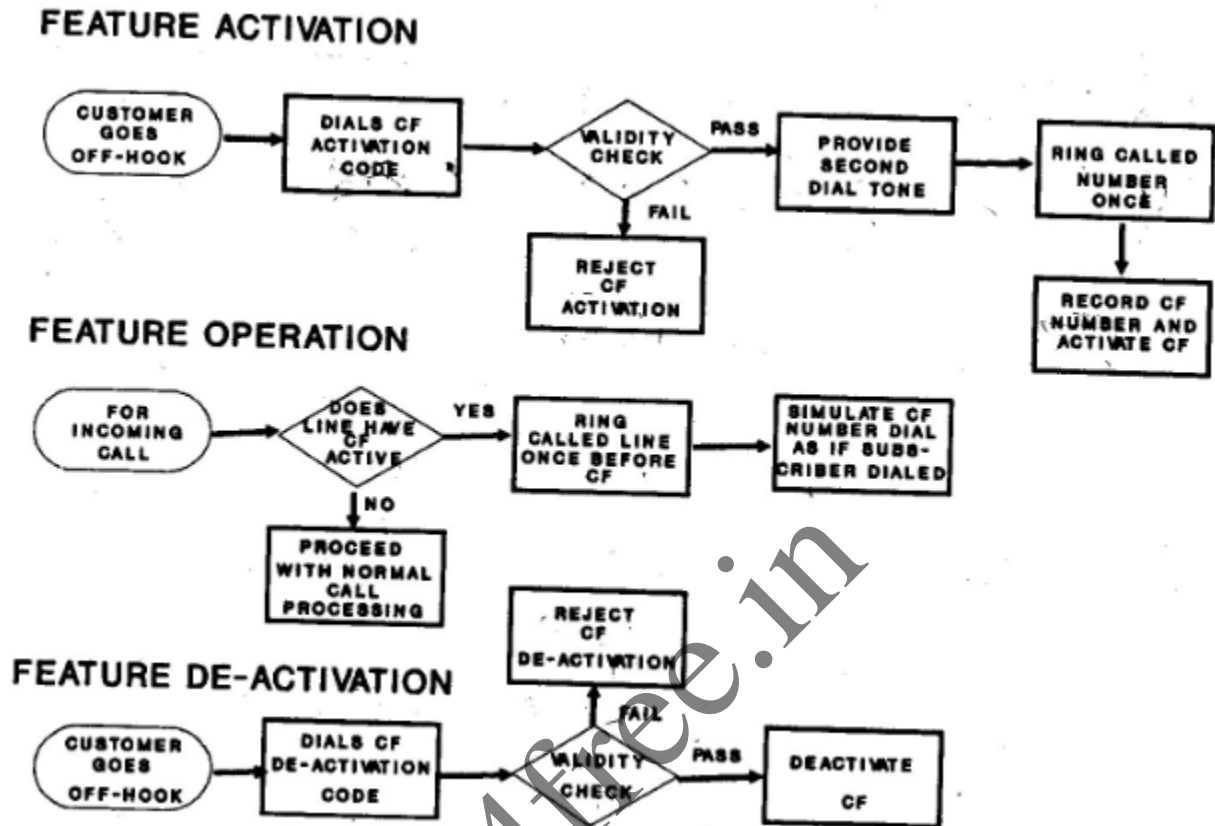

Figure 4.15a Feature Activation Figure 4.15b Feature Operation Figure 4.15c Feature De-activation

Feature Operation

Here the subscriber receives a call on the line that has the CF features activated. The system rings the called subscriber once and then forwards the call to a number previously recorded by the subscriber during feature activation.

Feature De-activation

This feature can be deactivated when the subscriber goes off-hook and dials the deactivation code. If the code is valid, the CF number is removed; otherwise, the deactivation request is ignored.

b. Feature interaction.

Due to hundreds of features supported by the modern DSS, feature interaction is necessary. One way to overcome this is to conduct regression test on the software and the related hardware.

TEXT BOOKS:

1. Telecommunication and Switching, Traffic and Networks - J E Flood: Pearson Education, 2002.
2. Digital Switching Systems, Syed R. Ali, TMH Ed 2002.

MODULE-5

MAINTENANCE OF DIGITAL SWITCHING SYSTEM: Introduction , Software maintenance, Interface of a typical digital switching system central office, System outage and its impact on digital switching system reliability, Impact of software patches on digital switching system maintainability, A methodology for proper maintenance of digital switching system. **A GENERIC DIGITAL SWITCHING SYSTEM MODEL:** Introduction, Hardware architecture, Software architecture, Recovery strategy, Simple call through a digital system, Common characteristics of digital switching systems. Reliability analysis. [Text-2] 8 Hours

CHAPTER 1: MAINTENANCE OF DIGITAL SWITCHING SYSTEM

5.1 Introduction

In this chapter we are studying the basic information that is needed to assess the maintainability of a central office.

5.2 Scope

We learn the typical interfaces that are utilized in maintaining CO both locally and remotely. CO maintenance such as fault reports, software patches, and the software and hardware upgrade process and firmware.

5.3 Software maintenance

Digital switch maintainability can be grouped into two categories.

Supplier initiated Software maintenance: This consists of software maintenance actions needed to upgrade a generic release of a digital switch. Software correction required to correct faults included here.

Software maintenance by site owners: These are routine maintenance actions that must be performed by the site owners of a digital switch. Examples could be routine diagnostics, updating of translation tables, and addition of lines and trunks to digital switch.

5.4 Interface of a typical digital switching system central office:

Most of the common interface of a typical digital switching system central office is shown in figure 5.1. The maintainability of a CO depends on satisfying the needs of all these and other interfaces. A group of CO is assigned to a switching control centre (SCC).

The next level of maintenance is assigned to the electronic switching system assistance centre (ESAC) in parallel with the maintenance engineers.

The ESAC organization usually controls generic upgrade, patching, operational trouble reports (OTRs), and interfaces with the supplier's regional assistance centers (RTACs) and technical assistance centers

(TACs) to solve unusual and difficult maintenance problems. The maintenance levels vary from one company to other. The other departments interact with digital switch are.

Engineering support:

- This department writes the new specification for a new digital switch and engineers addition to the existing CO.
- This department interfaces with the suppliers engineering department, CO plant department, and traffic department.
- This provides the accurate engineering specification for the new digital switch installation or addition.

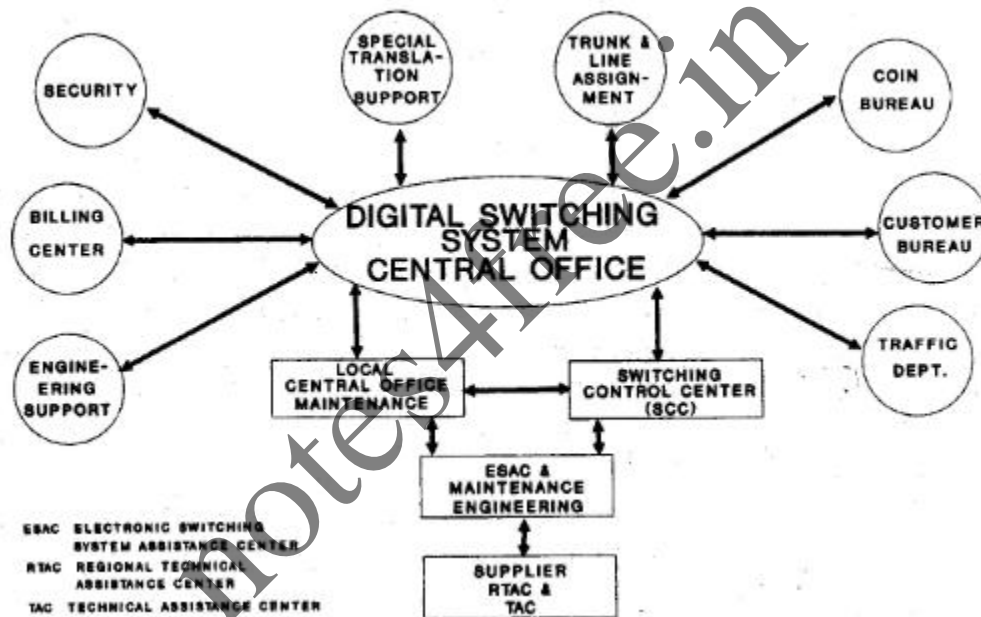

Figure 5.1. The common interface of a typical digital switching system central office

Billing center:

Billing centre is responsible for processing automatic message accounting (AMA) or billing tapes from a CO to produce customer bills.

Security

This department provides security services for the digital switching system to prevent unauthorized access and fraudulent translations of the telephone service.

Special translation support

This group provides support in establishing unusual translation for CO. these include the special service like complete call routing and trunk translation etc.,

Trunk and line assignment:

The main function of this group is to assign lines and trunks to a digital switch's line equipment and trunk equipment. It also maintains the databases of line and trunk assignments.

Coin bureau:

Coin telephones employ different instruments and operators. Coin equipment is maintained by the separate department. Special coin collection signals and special line translators are also employed. To solve any coin related problems this department takes help from the SCCs and ESACs.

Customer bureau:

This department is a single point of contact for telephone customers with requests for telephone connection, disconnections reconnection, and telephone problems. It works with line and trunk assignment group and SCCs.

Traffic department:

This group model and study telephone traffic through a digital switch. It recommends the additions and removal of trunks in a Co. this group interfaces with the engineering support group.

5.5 System outage and its impact on digital switching system reliability:

Digital switch outage represents the most visible measure of switching system reliability and affect maintainability. The causes of digital switch outages have been classified into four categories.

Software deficiencies

This includes software "bugs" that cause memory errors or program loops. These can be cleared only by major initialization.

Hardware failure

This relates to simplex and/or duplex Hardware failure in the system which results in system outage.

Ineffective recovery

This includes failure to detect trouble until after service has been impaired. This will properly isolate faulty unit due to shortcoming of the software and/or documentation.

Procedural error

These are "cockpit" or craft errors which have caused loss of service. Examples may include inputting wrong translation data or taking incorrect action during repair, growth, and update procedures.

5.6 Impact of software patches on digital switching system maintainability:

The frequency of generic releases for a DSS is usually limited to a few times a year. In these generic releases all software corrections are incorporated via patches. Patches are a “quick fix” or program modification without recompilation of the entire generic release.

In real time operational systems, it is difficult to install patches since system works continuously and patches have to be applied without bringing the system down.

5.6.1 Embedded patcher concept

- The concept of resident patcher program is explained in this section.
- In first generation digital switches, field patching was performed by hard writing encoded program instructions and data at absolute memory location.
- This technique is viable, created many problems in the operation of a digital switch.
- The mistakes were made in applying the wrong data to wrong addresses, patching incompatible generic releases, and applying that are out of sequence.
- Embedded patcher programs that operate as software maintenance programs and reside in the digital switches have overcome this problem.
- By using the proper design specification of Digital switching functions, coupled with exhaustive regression testing of software-hardware interfaces, we can reduce the number of patches in the field.
- The current state digital switching software requires large number of patches needing excessive maintenance effort by the owner of digital switching system.

5.7 Growth of digital switching system central offices

- The growth is the important thing in the lifetime of a digital switching system.
- The growth means the upgrading of a system software or hardware.
- This process represents a major effort for maintenance organizations such as SCCs and ESACs.
- The complexity of the upgrading the digital switch comes from its nonstop nature, real time operational profile, and the complexity of software and hardware involved.
- The exact upgrade process for each digital switch is usually documented by the supplier.

7.7.1 Generic program upgrade:

This process varies among the supplier's. The most important thing is not the upgrade process, but how digital switch is prepared to accept a new release. Following are the points required in the method of procedure (MOP) used in the digital switch and a CO.

- Time required for the entire upgrade process to happen.

- Availability of the switch during that period
- Dumping of the existing data tables those need to be repackaged with the new release.
- Verification of old tables with the new tables to ensure that all old functionalities are supported in the new release.
- The synchronization of hardware availability and software upgrade if hardware upgrade is included along with software upgrade.
- Establishment of software patch levels for the upgrade process
- Supplier support before, during and after the upgrade of the generic release.

5.8 A methodology for reporting and correction of field problems

In this section we are studying the internal and external (field) schemes of reporting faults. A very simplified problem-reporting system is shown in figure 5.2

- Fault reports from various sources such as testing, first office application failures, operational (CO) failures, and failures observed during the upgrade process are sent to a fault-reporting database.
- Fault-reporting database can be used to record the correction history and assign fault report numbers, fix priorities (critical, major, and minor) and track time required to fix.
- The fault reporting metrics receives the problem and forward to the owner module for correction. Depending on the type of the fault the module owner solve the problem in the current generic program with patches or to postpone it for the complied correction in the next generic program.
- The fault reporting metrics can be used to record correction history. These can also be enhanced to breakdown the causes of failures and in aid in root-cause analysis of faults.

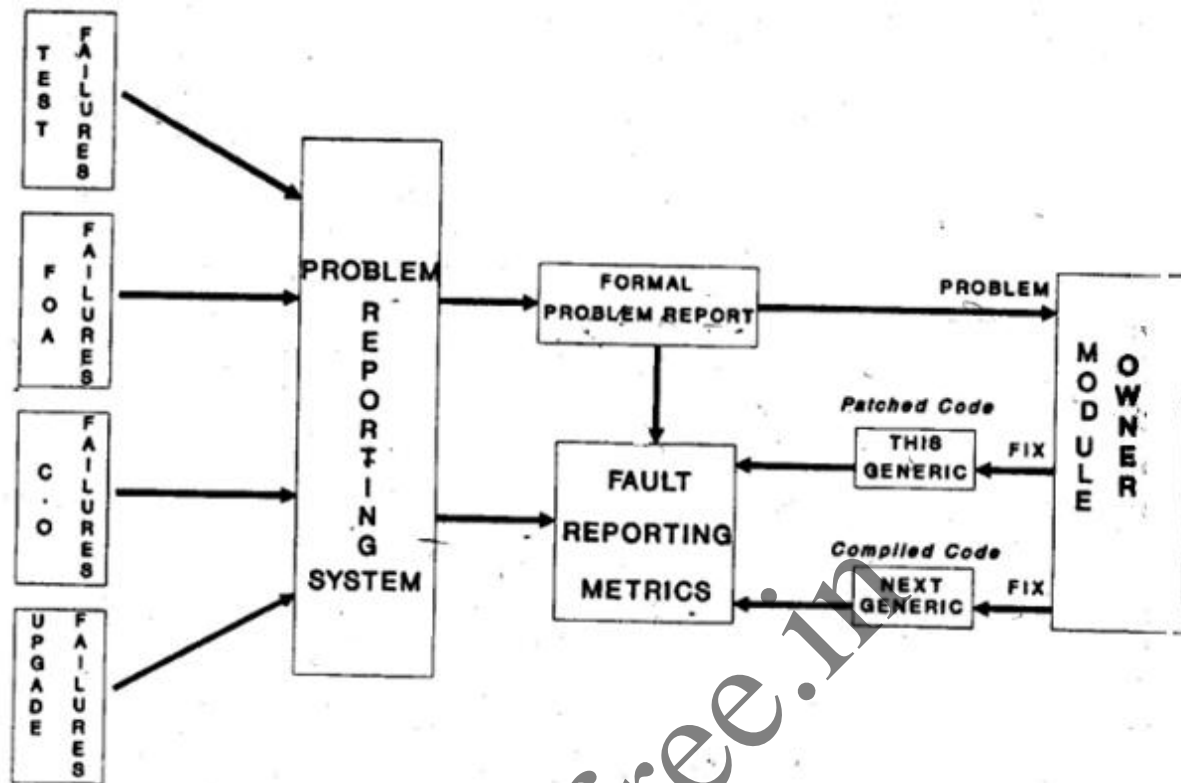

Figure 5.2: A simplified problem-reporting system

5.9 Diagnostic Capabilities for proper maintenance of digital switching system:

- For the maintenance of DSS effective diagnostic programs are necessary and these reduce the maintenance cost.
- Circuit packs also called plug-ins or circuit card assemblies are necessary in maintenance. Circuit packs will be stored in COs, but these are very costly.
- The COs is remotely managed via SCCs and ESACs.
- SCCs and ESACs require DSS maintenance programs that support remote diagnostics as well as provide high accuracy diagnostic results.
- In the past, switching system employed a large number and types of circuit packs, and diagnostics capabilities.
- All modern DSS are using a smaller number of circuit packs, because a single high density circuit packs impact many functionalities of digital switch.

5.10 Effect of firmware deployment on digital switching system:

- The recent trend in distributed processing of digital switching system has resulted in increased use of firmware.

- Firmware impact is substantial on digital switching system reliability and maintainability.
- The subsystems in DSS require resident non volatile object code for the purpose of booting or bringing the system online after a loss of power or system failure. These semiconductor memory types are often called as firmware devices.
- Firmware is often used to include the program code stored in the device.
- In telecommunication terminology, firmware can be defined as executable code or data which are stored in semiconductor memory on a quasi-permanent basis.
- This requires physical replacement or manual intervention with external equipment for updating.
- With the trend towards distributed architecture in DSS, the use of microprocessors controllers embedded throughout the system has increased rapidly.
- Typical DSS may have 20 to 30 percent of their program code embedded in firmware.
- The present switches adopt many call processing functions on the line cards, they function themselves.
- The line cards capable of detecting line originations, terminations, basic translation, and service circuit access control.
- Firm based programs require no backup magnetic media and provide local recovery of line service with minimal manual intervention with external equipment for updating.
- The updating process may involve erasing and/or programming equipment or special commands and actions from a host system for updating electrically erasable/ programmable firmware devices.
- During the updating process, the switching system controllers may be required to operate in simplex (without redundancy).

5.10.1 Firmware-software coupling:

Following are the number of problems created due to the need of change in number of firmware packs

- Increased simplex times for switches during the firmware update process
- Increased switch downtime due to system faults while in simplex mode, required initializations for firmware changes, insertion of defective firmware circuit packs, and damaged circuit packs due to electrostatic discharge(ESD)
- Increased maintenance problems due to procedural errors
- Delays in the upgrade process because of shortages of correct versions of firmware packs
- Increased incompatibility problems between firmware and operational software

The coupling between firmware and software can be measured as the ratio of firmware circuit packs (which are changed in conjunction with a generic or major software change) to the total number of firmware circuit packs in the system.

A low ratio indicates a loose coupling between hardware and software and a high ratio indicates a tight coupling. To reduce the frequency of firmware changes in the field, firmware should be decoupled as far as possible from other software. The extent of coupling should be documented. A list of coupled firmware and the firmware's function should be provided.

5.11 Switching system maintainability metrics

Following subsections describes a metric based methodology for assessing maintainability of digital switching systems. Fig 5.3 shows basic metrics with arbitrary scores.

score	0	1	2	3	4	5	score
maintenance process							
1.Upgrade process success rate	40%	50%	60%	70%	80%	90%	
2.Number of patches applied per year	or less 600	500	400	300	200	or more 100	
3.Diagnostic resolution rate	or more 45%	55%	65%	75%	85%	or less 95%	
4.Reported faults corrected in days (critical faults)	or less 6	5	4	3	2	or more 1	
5.Reported faults corrected in days (major faults)	or more 55	50	45	40	35	or less 30	
.....	or more					or less	
.....							
.....							

N= number of questions

Average score= Σ score/N

Figure 5.3 switching software maintenance questionnaires

5.11.1 Upgrade process success rate:

The first metric in the figure 5.3 shown assess the upgrade process. For example if the success for upgrade process of a digital switching system is only 40 percent of the time, a score of 0 is given; a score of 5 is given for success rates of over 90 percent. A thorough understanding of the upgrade process for a particular DSS is necessary before one can generate a score as shown in figure5.3.

The impact of customer cooperation during the upgrade process, and the time required for the upgrade process need to be considered in measuring the success of an upgrade process.

7.11.2 Number of patches applied per year:

A large number of patches impact digital switching system reliability and maintainability. Therefore number of patches applied in a year is good indication of system maintainability. An arbitrary sample is shown in figure 5.3.

The Figure 5.3 describes a situation in which a single fault generates a single patch and the CO personnel are involved in patching the switch. The example 5.3 shows that if the number of patches is greater than 600, then score is 0, if there are 100 patches or fewer, then score 5 is entered and so on.

5.11.3 Diagnostic resolution rate:

The modern DSS use the diagnostic programs correctly to determine the name and location of faulty unit, down to the circuit pack level. Therefore diagnostic programs should have good resolution rates.

Diagnostic is conducted remotely, and a technician is dispatched with correct circuit packs.

Repair times that were used in **Markov models** will depend on the accuracy of diagnostic programs.

As shown in example 5.3, this assigns a value of 0 if the diagnostic program can pinpoint defective circuit packs with an accuracy of 45% or less and 5 if the diagnostic accuracy is over 95%. This is an arbitrary example.

5.11.4 Reported critical and major faults corrected:

- Fault reporting and correction plays an important role in maintaining a digital switching system.
- There are some industry guidelines. Example Bellcore's Reliability and Quality Measurements for Telecommunication system, which requires that all critical faults be fixed within 24 hours and all major faults in 30 days or fewer.
- In example shown in figure 5.3 establishes a score of 0 if critical faults were not corrected in 6 days or fewer and 5 if the critical faults were corrected within 1 day.
- Similarly for major faults a 0 score is entered if the major faults are not corrected in 55 days or more and a score of 5 for 30 days or fewer.

CHAPTER 2: A GENERIC DIGITAL SWITCHING SYSTEM MODEL:

5.12 A strategy for improving software quality:

A strategy for improving digital switching system software quality is shown in figure 5.4. It is based on the process metric, defect analysis and a continuous improvement program.

A good example of software metrics is Bellcore's *In Process Quality metrics*. And the field metric is Bellcore's *Reliability and Quality Measurements* for Telecommunication systems. In this strategy as shown in figure 7.4 we have four distinct processes, they are namely

- Program for software process improvement
- Software processes
- Metrics
- Defect analysis

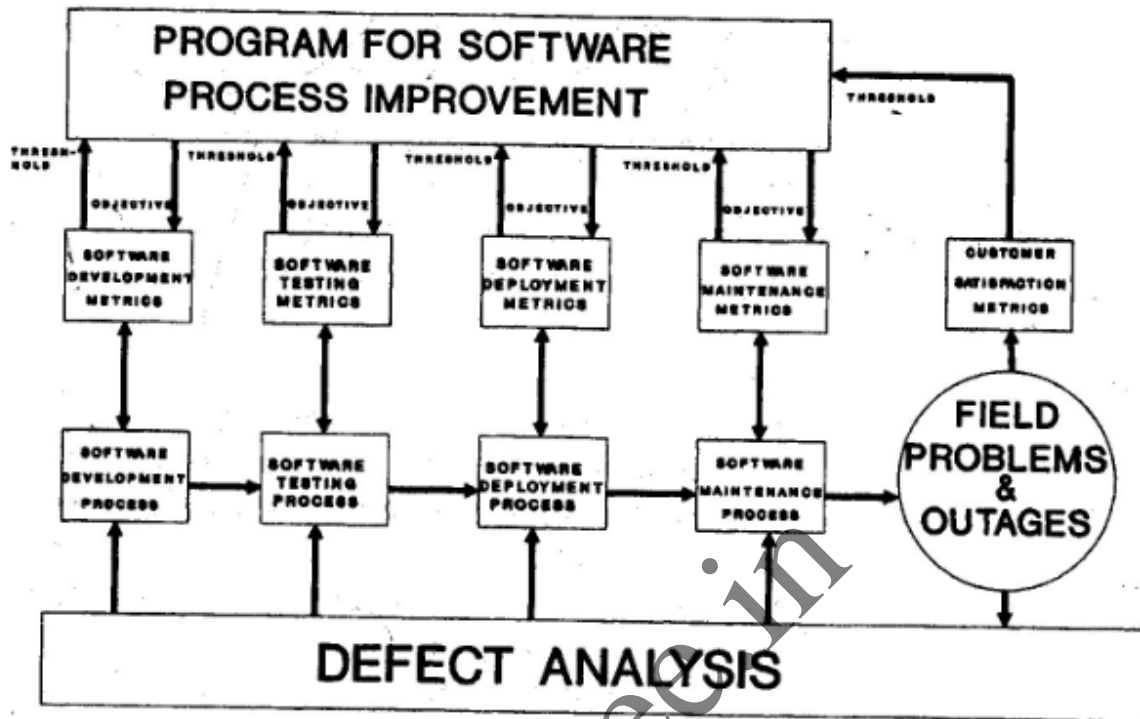

Figure 5.4 a strategy for improving software quality

5.12.1 Program for software process improvement:

- It is the heart of the system.
- Software processes for the digital switching system are usually large and complex.
- These processes must be documented and base lined by putting them under a configuration management system.
- Configuration management system will allow tracking of any changes to the process and help the process administrator to better understand the impact.
- A process change does not always improve a process, but a continuous-improvement program (CIP) improves the process.
- The CIP strategy varies for different processes, projects, or products. The strategy, in this model assumes that the processes can be instrumented.
- The inputs to the improvement processes are the thresholds established for different metrics and these are used to observe the impact of changes on all processes.
- A set of new thresholds is fed to the metric system, when the process is changed.
- This process is implemented continuously to improve the quality of the system software.

5.12.2 Software processes:

The Software processes always relate to the software metrics, these include

- Software development process

- Software testing process
- Software deployment process
- Software maintenance process

5.12.3 Metrics:

There are five types of metrics for this strategy. This strategy can be adapted to work with any set of available set of metrics. The metrics shown in figure 5.4 are

Software development metrics:

- These metrics define measurements related to the life-cycle phases of a software development process and measures the effectiveness of these processes.
- Typical life-cycle development phases include the software requirement process, high-level design, low-level design, and software coding.

Software testing metrics:

- Software testing metrics measure the effectiveness Software testing process.
- Typical measurement include the number of test cases planned versus the number of cases executed, testing effectiveness, coverage etc., applicable to all test life cycles.
- For DSS the test life-cycles include unit testing, integration testing, feature testing, regression testing, and system testing.

Software deployment metrics:

- These metrics collected during the deployment of a release in the CO.
- The most effective metrics in this category are the application success metrics and the number of patches applied at the time of deployment.
- The number of patches applied during the deployment process also must be minimized.

Software maintenance metrics:

- These metrics collected once the release is installed.
- The most important metrics are the number of software patches applied, number of defective patches found, and effectiveness of the diagnostic programs.

Customer satisfactions metrics:

- These metrics collected from the customers of the DSSs.
- Examples are billing errors, cutoff during conversation, slow dial tone, and other digital switch related problems.

5.12.4 Defect analysis

- A defect analysis is a base program for this strategy. It drives the continuous –improvement program. After a release becomes functional in the field, it will eventually experience failures.
- Field failures are usually classified according to severity.
- Field failures that cause system outages are classified as *critical*, followed by less severe ones as *major* or *minor*.
- A causal analysis of all failures-especially, critical and major ones –is conducted first. After causal analysis, the causes of failure are generally categorized as software, hardware or procedural. This strategy only explains the software processes.

Analysis example:

In this we are applying causal analysis to the digital switching system. Based on the software architecture of this digital switch, a software problem may have originated from

- Central processor software
- Network processor software
- Interface controller software
- peripheral software (lines, trunks, etc)

The next step is to identify the software subsystem that may cause the problem.

- Operating system
- Database system
- Recovery software
- Switching software
- Application software.

Depending on the digital switching architecture, this sub categorization process can be long and complicated. Once the classification of the field failures is completed and failing software module is identified. To identify the failed module and life cycle phase a search is conducted. A patch is issued to correct the problem.

Field trouble report: To understand this strategy, let us analyze the following trouble report.

Name of digital switch: Digital switching system type, class 5

- Location: Any Town, Karnataka
- Type of failure: Software
- Duration of failure: 10 minutes
- Impact: Lost all calls
- Priority: Critical

Explanation: During heavy traffic period, the digital switching system lost all call processing. An automatic recovery processes initialized in the system. The system recovered in about 10 minutes. Later some patches were added to correct feature X problems. Feature X was deactivated as a precaution.

Typical analysis:

The following phases are considered to perform the analysis, they are

- Requirements phase: The Requirement was incorrectly captured, causing the design and code to be defective.
- Design phase: captured Requirement was correct, but the translation of Requirements to design was wrong, causing defective code.
- Code phase: captured Requirement was correct, the translation of Requirements to design was correct, but written code was defective.
- Test phase: captured Requirement was correct, the translation of Requirements to design was correct, written code was correct, but the testing phase did not detect the problem.

A good test methodology for digital switching system should check each feature under a realistic software conditions before it is released. All metrics that measure the effective of testing should include testing with high traffic as an input data point.

5.13 Introduction:

In this chapter we are going to study the functionalities of the hypothetical digital switch to explain the overall hardware and software architectures of a typical class 5 switch.

5.14 Scope:

A generic digital switching system and its hardware and software architectures are created. Typical calls through the switch are traced to reveal the functionalities of an operational digital switching system. A system recovery strategy for the hypothetical digital switch and digital switch analysis report is covered.

5.15 Hardware architecture:

The hardware architecture of a hypothetical digital switch is shown in fig 5.5. It is based on quasi-distributed control architecture. The architecture of a DSS is very complex with many subsystems. It consists of following main modules.

a). Central processor: It is a primary processor in the digital switching system and it is always duplicated. The function of central processor is to provide system wide control of the switching system. It supports secondary processors, as network control processors (NCPs).

The CP control the high level functions of the switch and supports operation, administration, and maintenance (OA&M) functions. The CP controls the system recovery process during critical faults. The CP maintains subscriber and office data. It supports billing system for the switch.

b). Network control processors (NCP): The NCPs are the secondary processors. They provide call processing functions and assist in setting up a path through the switching fabric. Many number of NCPs

are present in generic switch, they are usually duplicated and depend on the desired size of the class 5 central office. NCPs are interface with Interface controllers (ICs) and provide medium level call processing support.

NCPs are associated with particular ICs, to keep track of all calls controlled by the ICs and associated path assigned for it. NCPs interfaces with other CPs or NCPs to update call paths on a regular basis, for global view of all calls for other NCPs.

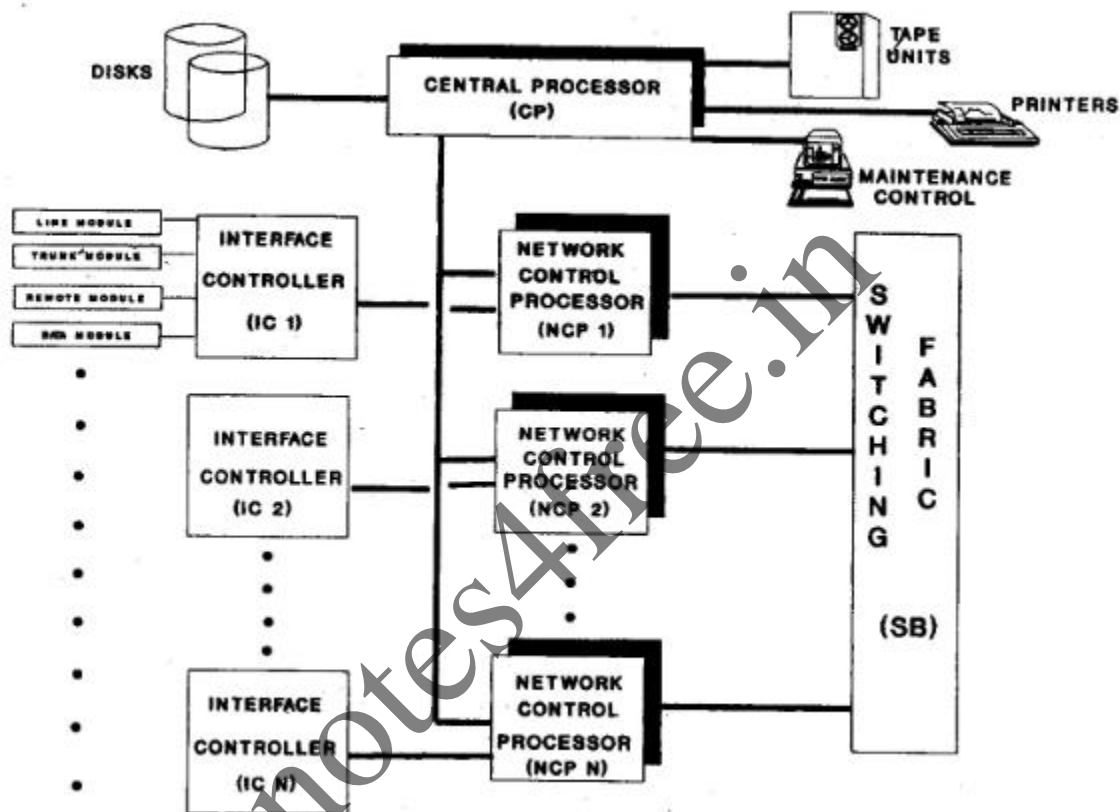

Figure 5.5. A generic switch hardware architecture.

c). Interface controllers: Most digital switching systems (DSSs) employ a processor based controller that acts as concentrators of all incoming lines or trunks. These concentrators use time multiplexed output to the NCPs and provide time switching (T-switch) functions.

d). Interface modules: The interface modules used in the DSS are Line modules (LMs), Trunk modules (TMs) and special modules. Line module may terminate a single line or scores of lines. Most DSSs use smart line cards that are processors driven. A smart line card performs basic call processing functions such as line scanning, digit collections, and call supervision.

The trunk modules (TMs) interface different types of trunks to the DSS. Most DSS employs special modules to connect integrated service digital network (ISDN) and other digital services such as Advanced Intelligent network (AIN) and packet switching to the switch.

e). **Switching fabric:** Most digital switching systems use at least one space or S switch. The concentrators in the ICs are time or T switches. The S switch is usually accessible to all NCPs. In some cases, the switching fabric is partitioned for use by different NCPs.

5.16 Software architecture:

Typical DSS software is discussed in this section. Generic switch software architecture is shown in figure 5.6.

1) System-level software:

Most DSS employ the System-level software. Software at this level is a multitasking operating system (OS) is based on duplex mainframe computer. The function of the OS is to control each application system (AS) developed by the DSS. Basic software systems for the digital switch can be classified as

- Maintenance software
- Call processing software
- Database software

2) **Maintenance software:** The software industry spends almost 80% of its effort in maintaining software. Digital switch maintainability can be grouped into two categories.

- **Supplier initiated software maintenance:** this consists of software maintenance actions needed to update or upgrade a generic release of a digital switch. These also include application of “patches” or software corrections required to correct faults in the existing generic release.
- **Software maintenance by site owners:** These are routine maintenance actions that must be performed by the owner of a digital switch to keep it operational. E.g., addition of lines and trunks to the digital switch.

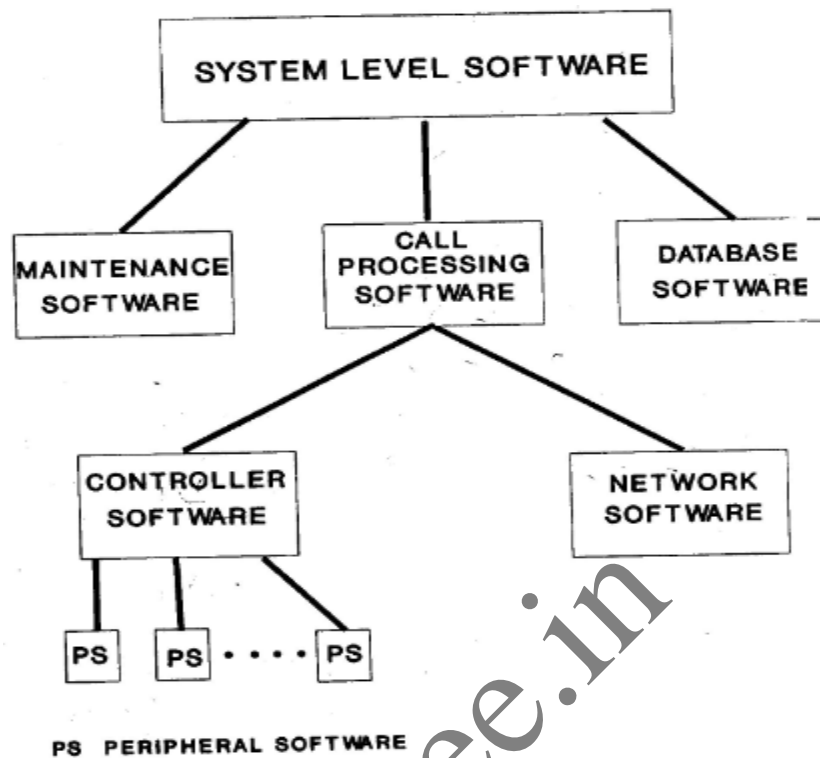

Figure 5.6. Generic switch software architecture

3). Call processing software: Based on the architecture of the DSS, the call processing program can be divided into three levels

1. High level functions
2. Medium level functions
3. Low level functions

High level functions: High level includes call processing functions that require support from a central processing unit. Examples are specialized billing, office data, and translation data.

Medium level functions: These are referred to as network software. These reside in the network processing units. This level includes call processing functions such as establishing a path through the switching fabric, verifying a subscriber and maintaining a call map. These are called as network software in figure 5.6.

Low level functions: These are shared between the interface controllers and the line modules depending on the architecture of the DSS. These functions may be line scanning, digit collection attaching service circuits, or call supervision. These are referred to as controller or peripheral software in figure 8.2.

4). Database software: most DSS employ the database system to record office information, system recovery parameters, system diagnostics, and billing information.

5.17. Recovery strategy:

Recovery strategy of a digital switch is based on a three-level scheme, these scheme depends o three control levels.

- Level 1 Initialization (INIT 1):
- Level 2 Initialization (INIT 2):
- Level 3 Initialization (INIT 3):

Level 1 Initialization (INIT 1): This is the lowest level of initialization for the digital switch. This INIT 1 recovery initializes all components that function at level 1 control. It is controlled and directed by the IC which control LMs, TMs, and peripheral modules (PMs).

This is called as local recovery, since it can initialize peripherals locally without impacting the operation of the entire DSS.

Example: After a thunderstorm, a technician in digital CO found 17 LMs, 5 TMs, and 2 PMs hung up (non-operational). This was resulted in partial outage and operational difficulties then technician use INIT 1 initialization for recovery.

Level 2 Initialization (INIT 2): This is the middle level initialization for all components that functions at level 2 control. This INIT 2 recovery could be directed for initializing the specified NCPs or a group of NCPs. In this hypothetical DSS, distributed architecture is used. Here NCPs controls the number of ICs, and ICs controls the LMs, TMs, and PMs.

If a duplex failure of a NCP pair occurs, or if a NCP breakdowns and backup NCP is not switch to active mode cleanly, then ICs connected to NCPs will be impacted. Then we use two types of recovery strategies are used.

If the problem is due to the NCPs switching from active mode to standby mode and the switch is not clean, then IC runs INIT 1 initialization on line, trunks, and peripherals. If that does not help, then INIT 1 needs to be run to initialize the NCPs and associated LMs, TMs, and PMs.

If the problem is due to processor switching, but to hard complex failure in the NCP pair, then INIT 2 needs to be run immediately. This is normally impact all the connected ICs and associated LMs, TMs, and PMs.

Example: A technician tried to switch a NCP with its redundant side after the diagnostic for NCP failed. Then technician can use INIT 2 Initialization to overcome this problem.

Level 3 Initialization (INIT 3): This is the highest level of initialization for a digital switch. This level of initialization functions at level 3 control. This INIT 3 recovery could be directed for initializing the CP and NCPs.

This level of initialization is run when the redundant CPs fail or the CP switch is not successful and the DSS cannot fully function with defective CPs. Here first recovery program identifies the problem in the last known good CP. It can work with reduced number of NCPs or NCP at all. After diagnosing the CP, then system will run INIT 2 process to synchronize all NCPs and bring them up on-line. This level of initialization will cause a total system outage.

Example: A DSS starts experiencing a slow dial tone, even after initializing the INIT2. Then technician may use this INIT 3, this solves the problem. This problem is mainly because of software corruption in the CP.

Manual recovery: Manual recovery of the digital switch is used when repeated use of INIT 3 does not recover the system. In manual recovery, the generic program with last known good office data selected subscribers data is loaded in the digital switch. The basic idea of Manual recovery is as follows:

- Bring up the system with manual effort since automatic runs of INIT 1, INIT 2, and INIT 3 failed to bring the system back to on line.
- Then current generic program and data may be corrupted, the system is updated with last known good generic program and data.
- Then manual or specialized diagnostics programs are used to identify recover the data.

5.18 A Simple call through a digital switching system.

A flowchart for typical call through a typical DSS is shown in figure 5.7.

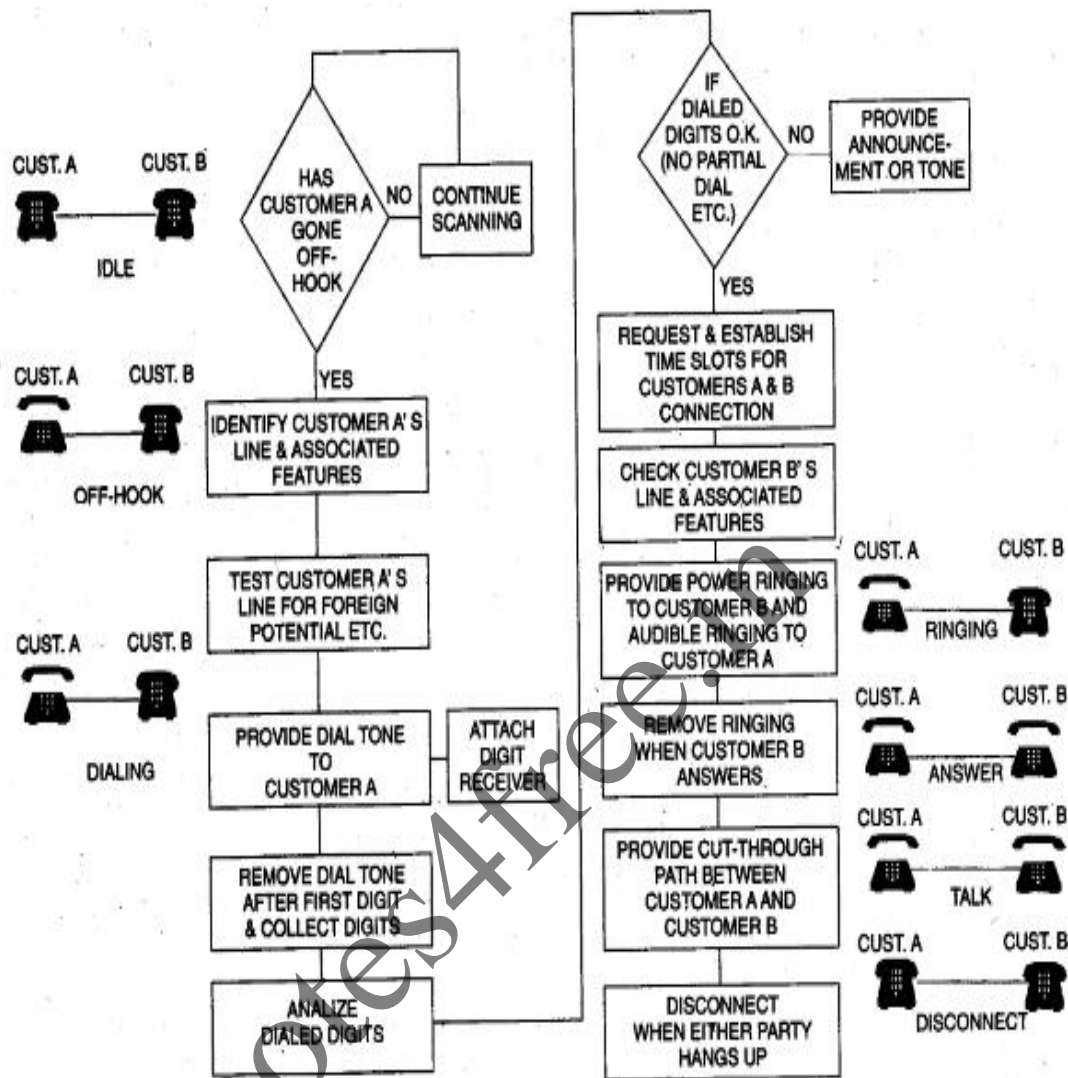

Figure 5.7 a simple call flowchart

The basic steps necessary to complete a simple call are as follows:

1. Detect off-hook condition
2. Identify customer's line
3. Test customers line
4. Provide dial tone to customer
5. Provide digits analysis of dialed number
6. Establish path between the calling customer and the called customer
7. Ring the called customer
8. Detect answer and establish cut through path
9. Supervise both lines for disconnect
10. Detect on-hook condition and disconnect

The common scenarios that typically occur in digital switch are discussed below

Line-to-Line Intra-IC call: Customer A calls customer B, within the same interface controller (IC) as shown in figure 5.8a. When customer A goes off-hook to call customer B, the call origination request is detected by the line module. It sends a message to the IC which in turn sends a message to the NCP.

The NCP validates the customer A's line. The IC attaches a digit receiver to the line and provides dial tone to the customer A. When customer A dials the first digit, the LM removes the dial tone from customer A's receiver. The dialed digits are then collected and sent to the CP for digit analysis.

If the dialed number is valid, then NCP assigns a time slot for the call connection path between customers A and B. Then customer B's line is checked for busy or idle, and a power ringing is applied to customer B's line. An audible ringing is simultaneously applied to customer A's line. When the time slot is allotted, customer A answers the call, cut-through path through the switching fabric. The first leg of the call from customer A uses 'T' switch of the IC, the second leg uses an 'S' switch through the switching fabric, and the third leg to customer B uses another 'T' switch through the IC. Most DSSs use TST switch. If either customer disconnects, the LM detects the on-hook condition and idles the connection.

If the dialed number is incorrect (e.g., partial dial or wrong prefix) and announcement or a tone is given to customer A.

Line-to-Trunk Intra-IC OGT call: Customer A calls customer B, who is served by another central office (CO), and the outgoing trunk selected lies in the same interface controller (IC) as shown in figure 5.8b. When customer A goes off-hook to call customer B, the call origination request is detected by the line module. It sends a message to the IC which in turn sends a message to the NCP.

The NCP validates the customer A's line. The IC attaches a digit receiver to the line and provides dial tone to the customer A. When customer A dials the first digit, the LM removes the dial tone from customer A's receiver. The dialed digits are then collected and sent to the CP for digit analysis.

If the dialed number is valid, then NCP assigns a time slot for the call connection path between customer A and an outgoing trunk for customer B's central office (CO). Then the terminating CO checks the customer B's line for busy or idle status, and applies power ringing to customer B's line. An audible ringing is simultaneously applied to customer A's line. When customer B answers the call, cut-through path through the switching fabric is provided via previously assigned time slots. As in line-to-line calls, each CO uses the TST connection. If either customer disconnects, the LM of either CO detects the on-hook condition and idles the connection. Call supervision is provided by the originating CO.

If the dialed number is incorrect (e.g., partial dial or wrong prefix) and announcement or a tone is given to customer A.

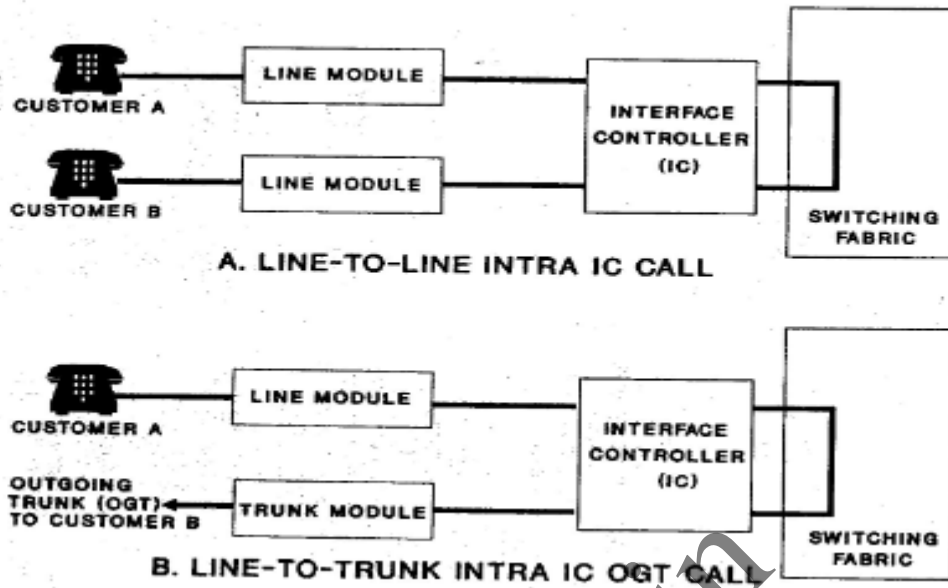

Figure 5.8a and 5.8b calls within the same interface controller

Line-to-Line Inter-IC call: Customer A calls to customer B, who is located in another Interface controller (IC), is as shown in figure 5.8a. This is same as Line-to-Line Intra-IC, except a path through IC-X and IC-Y is established for the call. The coordination between the NCPs (NCP-X for IC-X and NCP-Y for IC-Y) is provided by the central processors.

Line-to-Trunk Inter-IC call: Customer A calls to customer B, who is located in another CO, and a different Interface controller (IC) is as shown in figure 5.8b. . This is same as Line-to-Trunk Intra-IC OGT call, except a path through IC-X and IC-Y is established. The coordination between the NCPs (NCP-X for IC-X and NCP-Y for IC-Y) is provided by the central processors.

Trunk-to-Line Intra-IC IGT call: customer A is called by customer B, who is served by the another central office, and the incoming trunk selected lies in the same Interface controller (IC) as shown in figure 5.9a the CO for customer B homes into customer A's CO directly or through a tandem office via an incoming trunk (IGT).

If the trunk and customer A's line are in the same IC, a path is established through the switching fabric to the LM of customer A. the associated NCP assign time slot for IGT and customers A's line. Line A is validated and its busy or idle status is checked. A power ringing to customer A's line is applied by the IC, and an audible ringing is simultaneously transmitted to customer B's line via the IGT.

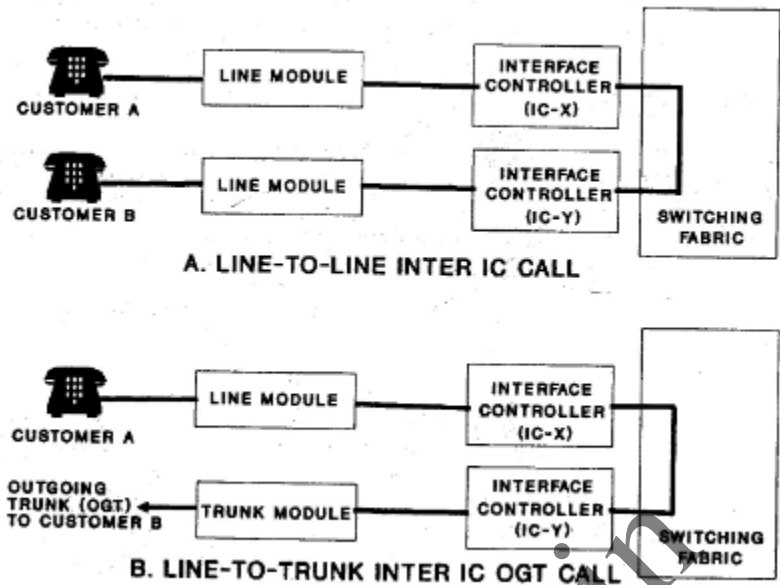

Figure 8.5a and 8.5b

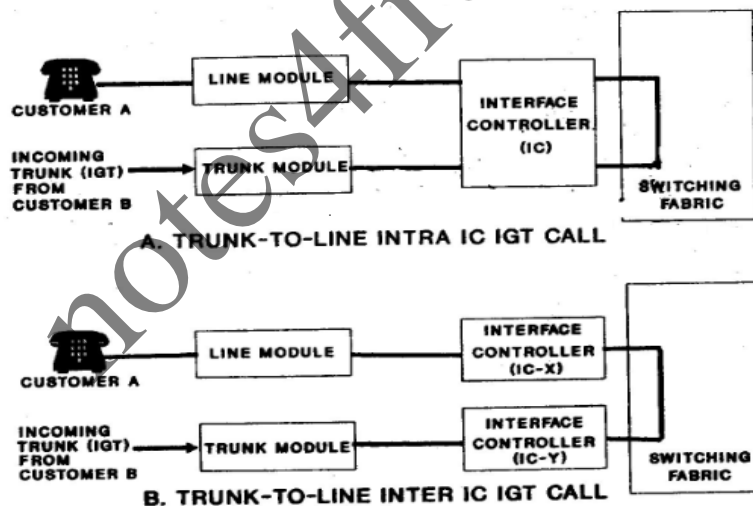

Figure 5.9a and 5.9b

When customer A answers customer answer the call, cut-through path through the switching fabric is provided via previously assigned time slots. As in line-to-line to calls, each CO uses the TST connection. If either customer disconnects, the LM of the either CO detects the on-hook condition and idles the connection. Call supervision is provided by originating CO.

Trunk-to-Line Inter-IC IGT call: customer A is called by customer B, who is served by the another central office, and the incoming trunk selected lies in a different controller (IC) as shown in figure 5.9b.to

connect call from A to B, a path through IC-X and IC-Y must be established. The coordination between the NCPs (NCP-X for IC-X and NCP-Y for IC-Y) is provided by the central processors.

5.19 Common characteristics of digital switching systems:

Most commercial Common characteristics of digital switching systems in the North American network are explained below.

- Dual capability: Most digital switching systems have class 5 or class4 capabilities.
- Termination capability: Most of the large digital switching systems can terminate approximately 100,000 lines or 60,000 trunks.
- Traffic capacity: In a distributed environment traffic capacity depends on digital switch configuration. Traffic capacity can as high as 2,000,000busy hour call attempts (BHCA's).
- Architecture-hardware: Most digital switching systems have a quasi-distributed Hardware architecture. All digital switching systems employ multi-processor subsystems.
- Architecture-software: Most digital switching systems maintain a modular software design, through layering or through functionalities. They have OS under which application system function. They support billing system for subscriber. E.g., automatic messaging system. They all support database systems for office, subscriber, and administration records.
- Switching fabric: TST (time-space-time) mode is used in the digital switching systems for switching calls.
- Remote operation: Most digital switching systems have remote switching modules (RSMs) to support switching function in a remote location.
- Advanced feature support: Most digital switching systems can support advanced features such as ISDN,STP,SCP, and AIN

5.19 Analysis report

Analysis report of a digital switching consists of two sections

- System description
- Operation administration and maintenance.

1). System description: this gives the high-level description of the digital switch being analyzed with following parameters.

- System overview: Describe the system -level functional blocks of the digital switch.
- Capacity: cover the busy hour call attempts of the digital switch for desired configuration.
- Hardware description: It gives the description of the hardware components of a digital switch required for desired configuration of equipment.
- Software description: describe the main software architecture of the digital switch with all major software components identified
- Call processing: describe the flow of different types of calls through the digital switch.
- Features list: describe all base features and optional features that need to be obtained separately.

- System recovery strategy: describe different levels of system initialization and typical times for system recovery for each level of initialization.

2). Operation administration and maintenance: It gives brief description of all maintenance features of a digital switch, with following parameters

- Database management: describe all database that need to be managed, e.g., office database, translation database, and billing database.
- Oss interface: Describe all types of operational support system.

3). Reliability analysis:

It mainly gives the reliability models of the digital switch and includes overall reliability findings covering.

- Components failure rates: describe the Components failure rates for different circuit packs used in the digital switch.
- System reliability: describe the results of hardware modeling of various subsystem of the digital switch.
- Software reliability analysis: describe the result of the software analysis of the digital switching system software.

4). Product support:

- Technical support: describe the different levels of technical support that the digital switching supplier provides. Time limit to correct the faults also included.
- Documentation: lists all the documents that will be supplied to maintain the DSS.
- Fault report system: describes a fault-reporting system that tracks all faults discovered by the operators of the DSS.
- Training: list all training courses available for telephone company personnel who will use and maintain the DSS.